



MANUAL FOR  
QUALITY, ENERGY  
EFFICIENT LIGHTING



NEW YORK CITY DEPARTMENT OF  
DESIGN + CONSTRUCTION

Prepared for  
NYC Department of Design & Construction by  
Gruzen Samton LLP with Hayden McKay Lighting Design Inc.  
January 2005; Expanded July 2006



This document is an introduction and resource handbook about quality lighting and energy efficient solutions for New York City projects. Its basic goal is to assist designers and project management personnel to understand the current energy codes and meet or exceed them with appropriate and creative designs. The guidelines are addressed to all the participants in projects for the NYC Department of Design and Construction (DDC) - administrators and managers from DDC; architects and their consultants; and construction managers. Quality and energy efficient lighting must be fully integrated with the overall design process, and planned in conjunction with daylighting strategies.



## EXECUTIVE ACKNOWLEDGEMENTS

**Honorable Michael R. Bloomberg, Mayor**  
City of New York

**David Burney, AIA, Commissioner**  
NYC Department of Design and Construction

**DDC Architecture and Engineering Division:**  
David Resnick, AIA, Associate Commissioner  
Margot A. Woolley, AIA, Assistant Commissioner  
John Kriebler, RA, Director, Office of Sustainable Design  
Laurie Kerr, RA, Office of Sustainable Design

# DDC MANUAL FOR QUALITY, ENERGY EFFICIENT LIGHTING

## TABLE OF CONTENTS

### OVERVIEW

Context of lighting in DDC projects	1
Compliance with energy codes	2
Relevance to NYC Department of Design and Construction	3
How to use this manual	4

### QUALITY LIGHTING & ENERGY CONSERVATION STRATEGIES

DDC – Strategies and Responsibilities	5
Design Team – Strategies	9

### SPACE TYPES – LIGHTING DESIGN BRIEFS

Office Design Brief	19
Library Design Brief	29
Adult Detention Facilities Design Brief	39
Warehouse Facility and Storage Design Brief	49
Workshop Design Brief	55
Corridors and Stairs Design Brief	61
Toilets, Lockers and Shower Design Brief	67
Building Exterior Lighting Design Brief	73
Parking Garage Lighting Design Brief	85
Firehouse Lighting Design Brief	95
Laboratories Lighting Design Brief	107

### IMPLEMENTATION RESOURCES

Lighting Technologies	121
Glossary	141
References and Internet Resources	147

### APPENDICES

A Energy Code Compliance	153
B DDC Form - Declaration of NYS Energy Code Compliance	159

The image shows a modern interior space. A vibrant red wall is the central focus, featuring a square window with a dark frame and a light-colored sill. Below the window, a horizontal strip of light is visible. The lower portion of the wall is clad in large, rectangular, light-colored tiles with a natural stone or wood-grain texture. To the right, a dark, possibly black, panel or structure is partially visible. The floor is composed of large, light-colored square tiles. In the upper left, a glass railing or partition is visible, suggesting a mezzanine level. A dark green rectangular box with the word "OVERVIEW" in white capital letters is centered in the upper half of the image.

## OVERVIEW

## OVERVIEW

Of New York City's roughly \$600 million annual energy bill for building operation, the municipal government spends 30%-40% (about \$200 million) every year on lighting. NYC's Department of Design and Construction (DDC) wants to reduce the amount of energy used for electric lighting while maintaining quality for DDC users. Analysis has shown that electric lighting directly consumes up to 50% of the total energy in many of DDC's buildings – and indirectly even more, because of the added cooling loads. Energy conservation saves natural resources, and it also lessens the impact of electrical production on air pollution and global warming. Finally metropolitan New York City is having difficulty meeting its current energy demands at peak times, which may result in more frequent blackouts or other disruptions. The NYC Energy Plan projects a shortfall of 2800 MW or nearly 25% of needed capacity by 2008.



photo: Hayden McKay, 1980

The joy of natural light in Grand Central Terminal, NYC

The New York State Energy codes are starting to require increasingly efficient lighting designs. In 2002, a new NYS Energy Conservation code took effect, which was considerably more stringent than the previous code, with stated limitations to the connected load for lighting in watts/square foot. In 2006, revisions to the 2002 code will take effect, and the watts-per-square-foot values for lighting may soon average 30% lower than those enacted in 2002. Since DDC requires that all their projects be in compliance with the most current codes, this will have an enormous impact on the way that lighting design is approached.

Strategies for conserving energy require both technology and design expertise. In response to energy conservation concerns, the technology options are evolving rapidly, making it an exciting time in the lighting design industry. Designers can count on more control and more reliability. Effective fluorescent lamps are available for most of DDC's applications, with more efficient shapes and better color rendering. Electronic high frequency ballasts have improved function and conserve energy. And lighting controls – switches, sensors and dimming devices – allow the lights to be used only when needed. Still, the design of an energy effective lighting strategy will depend on tailoring the technology to the user needs, especially for the diverse projects of the DDC.

While technology can make it relatively easy to reduce energy consumption, it can be challenging to do so while maintaining good lighting quality. DDC encourages a greater focus on lighting quality and new approaches to integrated building designs. Strategies include an emphasis on room surface reflectance, glare control, lighting commissioning and proper maintenance. Many time-proven strategies will become more prevalent in DDC projects, like “design with climate”, daylighting and task/ambient lighting. There are also more technological options that improve both quality and energy conservation, especially in the area of glare control, lamp efficiencies and lighting controls. A greater level of lighting design expertise and design team integration is required to achieve the qualitative and functional needs of a project's lighting, while meeting these new and restrictive energy codes.

While technology can make it relatively easy to reduce energy consumption, it can be challenging to do so while maintaining good lighting quality. DDC encourages a greater focus on lighting quality and new approaches to integrated building designs. Strategies include an emphasis on room surface reflectance, glare control, lighting commissioning and proper maintenance. Many time-proven strategies will become more prevalent in DDC projects, like “design with climate”, daylighting and task/ambient lighting. There are also more technological options that improve both quality and energy conservation, especially in the area of glare control, lamp efficiencies and lighting controls. A greater level of lighting design expertise and design team integration is required to achieve the qualitative and functional needs of a project's lighting, while meeting these new and restrictive energy codes.

**Daylighting** – using natural light as a primary source of illumination – is a time-honored approach to energy conservation and visual quality. Daylighting decreases not only energy consumption, but also lighting and cooling loads during the peak demand hours, reducing the stress on New York City's energy grid. For designers, an array of new technologies, such as skylights and monitors, louvers, light shelves and blinds, can make daylighting more effective, bring it deeper into the building and create a more balanced and comfortable effect. Although daylighting is beyond the scope of this manual, DDC strongly encourages its incorporation into all new buildings, and cites a number of resources in the Implementation Resources Chapter.

## COMPLIANCE WITH ENERGY CODES

All DDC projects are required to meet the Energy Conservation Construction Code of New York State, (hereafter called the NYS Energy Code) that went into effect July of 2002. The design team should be aware of the following:

1. The team is required to fill out a DDC form confirming that the design meets the energy code and to attach associated back-up calculations with description of methodology. (See Appendix B).
2. The Code is under revision and the changed code is expected to take effect in early 2007. There will be no grace period. Consequently, during the design phases project teams must be prepared to meet the energy code that will be in effect when that project is filed for a building permit.
3. The NYS Energy Code allows the use of the national energy standard, ANSI/ASHRAE/IESNA Standard 90.1 (hereafter called Standard 90.1) as an alternative methodology to show compliance under either the “prescriptive” or “whole-building performance” paths, described below. Standard 90.1 was jointly developed by the American Society of Heating Refrigeration and Air Conditioning Engineers (ASHRAE) and the Illuminating Engineering Society of North America (IESNA). The 2002 version of the NYS Energy Code allows the substitution of parts of Standard 90.1-1999. Revisions to the NYS Energy Code will likely allow the substitution of more current versions of Standard 90.1 (2001 or 2004).

The design team can select one of four ways to show lighting design compliance, by using one of the two paths below, alternatively described by either the NYS Energy Code or Standard 90.1.

- Prescriptive path (also called component compliance): Each energy system (component) of a building, (i.e., electrical/lighting, HVAC, envelope and service hot water) must comply with individual prescriptive requirements. Primarily, the lighting section includes minimum requirements for lighting controls, maximum connected load (based on watts per square foot tables) for the building interior lighting, and limitations on exterior lighting.
  - Performance path (also called whole-building compliance): All the energy systems of a building are analyzed together using energy-simulation computer software. A “base case” energy consumption is determined, using the minimum values allowed by the prescriptive method. The design of the actual project is then simulated using the same software, and the energy performance of the actual project must be the same or exceed that of the “base case”.
4. There are some exemptions that may apply, but these differ between the NYS Energy Code and Standard 90.1, and between the current and revised versions of the code. Such exemptions include some building types (e.g., historically registered), some project types (e.g., minimal renovation) or some types of lighting (e.g., surgical). The team should read the selected code or standard carefully, and verify such exemptions with the NYS Department of State Codes Division and the NYC building department.

Additional information regarding the energy codes can be found in Appendix A, and the form required by DDC, the Declaration of Energy Code Compliance, is located in Appendix B.



Renovation of an historic DDC building at New York City Aguilar Library

photo: Dub Rogers courtesy: Cruzen Samton

## RELEVANCE TO NYC DEPARTMENT OF DESIGN AND CONSTRUCTION

New York City is taking a leadership position in promoting lighting design that is both energy effective and high quality. The Department of Design and Construction, in its *High performance Building Guidelines*, sets forth compelling reasons and practical strategies for high performance lighting, and the agency has followed through on a number of pilot projects. Now that the energy codes are starting to catch up with the DDC's goals, DDC has a responsibility to ensure that the City's construction projects meet New York State's increasingly stringent energy code, at a minimum, and to do better where possible. With an annual construction budget for buildings of over \$500 million, DDC has the buying power to move New York's building industry in positive directions. DDC can also help teach the new techniques. This manual is part of DDC's efforts to develop broadly realizable sustainable strategies for its own use, which then can be made available to a wider audience, both within the City and beyond.

The DDC and other City agencies have already taken steps to encourage high performance lighting. DDC's Design Consultant Guide, August 2003, establishes lighting deliverables, in addition to requiring Energy Code compliance. The Department of Citywide Administrative Services, Office of Energy Conservation, (see [http://www.nyc.gov/html/dcas/html/dcas\\_oec.html](http://www.nyc.gov/html/dcas/html/dcas_oec.html)) has an established program, the Energy Cost Reduction Program (ENCORE), to assist City agencies in replacing less efficient lighting using financial support from the New York Power Authority (NYPA), the City's electricity provider.

The nature of DDC's Projects, with their variety and unique technical requirements, make it impossible to offer prescriptive solutions. This key aim of this manual is to inform DDC project personnel and consultants of the issues and to suggest approaches. Some past stumbling blocks that have inspired this manual include:

- *Wide range of technical needs / wide range of facility types.* DDC's projects include cultural institutions, such as libraries (young and old users), 24-hour buildings with varying occupancy, sleeping accommodations and high security installations. Finding practical solutions is always a challenge. The manual provides general strategies as well as "application guides" for a number of common DDC situations, such as shower/locker rooms or detention centers.
- *Agency standards and practices.* The City's user Agencies turn to DDC to manage their construction projects, but have their own functional standards and maintain their buildings after construction. The explanations in this document are meant to help with the coordination of requirements. It is strongly suggested that the specifications require commissioning of the lighting, and that the contractor submit maintenance manuals. There has been resistance to technology and lighting controls, particularly in high security situations. These strategies will need to be discussed individually and coordinated with code requirements.
- *Inexperienced consultants.* Some consultant teams are unfamiliar with the options for meeting the lighting and energy quality goals, due to inexperience with a specific space type (e.g. corrections) or the lack of a professional lighting designer.
- *Project reviews.* This manual has outlined steps and deliverables to be required from the design consultants, in order to make design review easier and more consistent. Over-lighting in the absence of lighting calculations, or in the pursuit of design uniformity, should be eliminated by requiring demonstration of code compliance.
- *Yesterday's technology.* The technology options available to designers and operators of the City's building are evolving quickly, and project personnel and user agencies need to understand the basics. This manual contains explanations of general strategies and an overview of the means available. For example, understanding the potential of controls might eliminate most energy-consuming night-lighting.
- *Centralized purchasing of lamps, replacement ballasts.* This had been an issue in the past. But the Department of Citywide Services (DCAS) has flexible means to replace a wide range of lamps, ballasts and controls. Virtually any lamp provided by the major lamp manufacturers can be purchased through DCAS.

## HOW TO USE THIS MANUAL

This document is a resource for the NYC Department of Design and Construction, its design consultants and project personnel. The material is offered as guidance and as an outline of good practice. It does not take the place of an experienced design team and an integrated whole-building design approach. It is not intended to be prescriptive or restrict creative solutions that meet the project goals in other acceptable ways. Resources include:

- Quality lighting and energy conservation strategies.** Responsibilities for DDC project managers and general strategies for design teams to meet the goal of high quality energy conserving lighting systems.
- Space-type strategies.** Guidelines for 8 space types common to DDC projects. These contain relevant quality and quantity recommendations provided by the Illuminating Engineering Society of North America (IESNA), plus relevant lighting power allowances for the New York State Energy Conservation Code and ANSI/ASHRAE/IESNA Standard 90.1 energy standards. These guidelines include suggested strategies for design layouts, energy conservation and lighting controls. References for additional guidance are included.
- Resources.** Several tools, specifically: outline of energy conserving lighting technologies for lamps, ballasts and lighting controls; sample specification language to address specific issues of energy conservation, sustainability, quality control, lighting controls and commissioning; glossary and references.



photo: mconnors, morguefile

Empire State Building, NYC

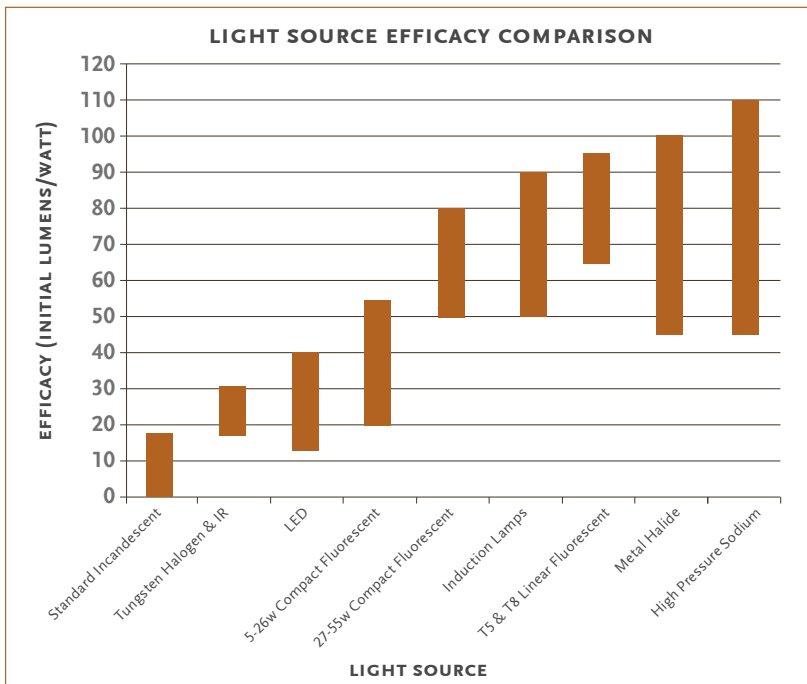

Relative efficiencies of common light sources



The image shows a modern interior space. A vibrant red wall is the central focus, featuring a square window with a dark frame. Below the window, a stone wall with a mix of grey and brown tones is illuminated from underneath, creating a warm glow. To the right, a dark, possibly black, wall or panel is visible. The floor is made of light-colored, square tiles. The overall atmosphere is contemporary and well-lit.

QUALITY LIGHTING &  
ENERGY CONSERVATION  
STRATEGIES

## DDC — STRATEGIES AND RESPONSIBILITIES

A quality, energy efficient lighting installation is a cooperative effort, requiring the attention and coordination of all parties: the DDC reviewer and project manager, as well as the design team. DDC can take a leadership position in its projects by understanding lighting issues and requiring that they be properly addressed by the design team.

### DEVELOPING THE REQUIREMENTS

- Choose the right team. Look for experience with similar space types, but more importantly seek experience in meeting the project goals such as energy conservation, daylighting, sustainability, LEED™, etc.
- Clearly delineate responsibilities and expectations and ensure the proposal and contractual scope of work is sufficient to meet these expectations.
- Contract for a sufficient number of team design meetings. More energy is saved and quality maintained if lighting is considered at the earliest stages of design and integrated into the architecture.
- Include a Lighting Designer. A lighting designer with expertise in energy efficiency is recommended on most DDC projects. Ensure that DDC review the selection of the lighting designer with DDC's Office of Sustainable Design. Projects where a lighting designer must be a required sub-consultant include the following:
  - Projects where aesthetics are paramount (theaters, historic restoration, museums, etc).
  - Projects where tasks are difficult or dangerous, or poor lighting has serious consequences. Example building types include offices, libraries, hospitals, correctional facilities, laboratories, workshops, etc.
  - Projects where daylighting can be a primary source of light.
  - Unusual projects or those with a level of complexity in which meeting energy and quality goals may be more challenging (zoos, museums, multipurpose spaces, industrial buildings, etc).
  - High Performance projects or projects considering a LEED™ rating.
  - Larger projects where potential for energy saving is significant.
  - Plan for commissioning to ensure that the lighting design intent is met. Lighting controls always require some level of “commissioning”, in the sense of setting, calibrating, verifying and documenting settings. The control equipment used to meet the minimum energy code requirements, such as timeclocks and occupancy sensors, require several levels of calibration, while more advanced controls such as those for daylight harvesting, DALI or preset dimming systems require a greater degree of commissioning. Determine and contract for all phases of commissioning, including development of a commissioning plan, specifications, supervision and documentation. Even if an outside commissioning agent is hired, the specifier of the lighting controls should be contracted to participate in the entire process.

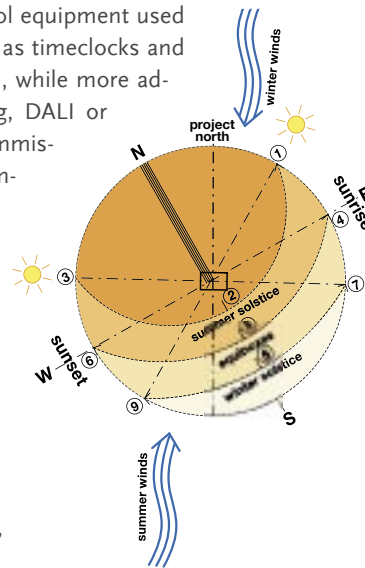

### PRELIMINARY PHASE RESPONSIBILITIES

- Include those design team members responsible for lighting in the earliest goal setting meetings.
- Discuss opportunities for daylighting, and suggestions for siting, orientation and fenestration.
- Encourage project owner's cooperation in considering changes to visual tasks. Encourage team to evaluate the owner's visual tasks and make suggestions for improvements (such as enlarging the point size of lettering) that would improve visual performance, lighting quality or reduce lighting consumption.

Schematic phase climate chart for Sunrise Yards, a DDC project in Queens, NY. Diagram courtesy Gruzen Samton.

## LIGHTING CALCULATIONS

Lighting is not an exact science, and an over-emphasis on engineering may not lead to a better design. Some recommendations:

1. Average maintained footcandle values, or “lumen method” calculations, are sufficient for most standard spaces, when lighting design professionals have expertise in similar spaces, for applications where layouts are recommended by professional design guides, or for spaces where design options for equipment or layouts are limited. For DDC projects, these are acceptable for preliminary design phases, for infrequently occupied or back-of-house spaces, for very typical spaces and for those projects in which DDC does not require point-to-point calculations.
2. Two-dimension software analysis provided by programs such as AGI, Lumen Micro, Lightscape, or CAD Light will be required for most DDC projects. The extent of the point-to-point computer generated analysis will be stated clearly in the project’s requirements. Situations for which this software analysis is most appropriate include the following: (These calculations may be performed by a sub-consultant or a manufacturer).
  - Daylighting studies
  - Heavily obstructed spaces like retail, warehouses,
  - Spaces with unusual shapes that cannot be estimated using the lumen method
  - Spaces where understanding the distribution is particularly important such as correctional facilities, homeless shelters, workshops, etc.
  - Spaces where the minimum, maximum and average illuminance is critical.
  - Spaces where luminance ratios are critical.
  - The two-dimension analysis is capable of providing grids or curves on the working plane and any work surface, showing both illuminance (fc) or reflected light (exitance) values.
3. Three-dimensional software analysis provided by programs such as Radiance, Lightscape, Lumen Designer 2004, etc., is a specialty tool and seldom called for on DDC projects. It should be limited in use for several reasons:
  - Visual three-dimension renderings cannot represent all perceptible lighting extremes which can exceed a million to one. The eye is capable of instantaneously discriminating luminance ranges of 1,000 to 1. Monitors and printers can only portray an image with a range of about 100 to 1, so renderings cannot reveal conditions of extreme contrast causing glare. Simpler, two-dimensional software produces adequate data related to luminance ratios.
  - The use of such software programs is extremely labor-intensive, and it should be explicitly agreed upon in the subconsultant’s contract or included later for an additional fee.
  - Such programs are highly complex, and prone to error. Considerable expertise is required to run the software, and to accurately interpret it.
  - While three-dimensional software, especially Radiance, can be more accurate than other software under certain circumstances, the additional cost and potential for inaccurate data should be carefully weighed against the perceived benefits.
4. Three-dimensional Physical Models for both visual demonstration and the collection of data for computer analysis can be a useful tool. Three-dimension physical models will allow the owner and design team to view the actual lighting conditions, including the luminance extremes, so may be the more appropriate choice of analysis for difficult design areas. The construction and daylight testing of physical models should be explicitly called out in the contract, or included later as an additional fee.

## SCHEMATIC PHASE RESPONSIBILITIES

- Ensure that DDC review the Project Lighting Power Allowance for the building, as prepared by design team and based on the relevant lighting energy code. Notify the team that the final design must meet the NYS energy code that will be in place when the project is filed with the building department. At the end of CD's the team will be required to submit a code compliance form and back-up demonstrating this. See Section D of this manual for Lighting Compliance forms. These forms will be reviewed by DDC prior to final approval.
- Ensure that DDC review the room by room detailed program report for conceptual approach to daylighting, electric lighting (sources and recommended fc levels) and suggested lighting control strategies.
- If daylighting studies are contracted for, ensure that DDC review daylighting calculations as appropriate for project type and difficulty. Summary should include worst case conditions (typically winter 9am, noon and 3pm under clear and overcast sky conditions), and minimum, maximum and average light levels. For some spaces, (art museums) or some purposes (plant survival) maximum levels and annual hours of availability are relevant.
- Electric lighting layouts and calculations are usually premature at this phase.
- Encourage team to integrate lighting in the total building design and do not wait until later phases to address.

## DESIGN DEVELOPMENT PHASE RESPONSIBILITIES

- Note that light level calculations are required at the end of Design Development. (See sidebar re calculations.)
- Ensure that lighting layouts, lighting schedule, fixture cuts, and calculations are reviewed by DDC.
- Evaluate lighting design on the following merits:
  - Does it meet the project's qualitative and quantitative goals?
  - Will it be acceptable to the occupants?
  - Does it meet energy conservation and sustainable goals?
  - Is it reasonably maintainable?
  - Does it meet safety standards?
- Request that the Finish Schedule for all interior materials includes a column for light reflectance values, expressed as percentages or equivalent decimals between zero and 1.0. This is necessary input for the light level calculations, and is valuable for educating the design teams and increasing the efficiency and comfort of lighting systems. (Reflectances are available from manufacturers of paints and most materials.) Listing actual values is important because colors absorb far more light than most people would estimate.
- Have the designer or the commissioning agent prepare a preliminary commissioning plan for lighting that includes the need for specifications, settings, calibration, fine-tuning and aiming, documentation, maintenance manuals, training, and ongoing commissioning efforts.
- Remind the team that the project will be reviewed for compliance with the energy code prior to final approval.



photo: John Bartlestone courtesy: Gruzen Samton

Roslyn Public School, Roslyn, New York

## CONTRACT DOCUMENT PHASE RESPONSIBILITIES

- Ensure that Energy Compliance forms and back-up are submitted during this phase and that they are reviewed by DDC.
- Ensure that DDC comments are incorporated into the contract documents
- Ensure that DDC review lighting layouts, lighting schedule, fixture cuts, calculations and control specifications.

- Ensure that DDC review to ensure that special considerations for codes, safety, energy, have been met.
- Ensure that DDC review specifications to ensure that they contain explicit language regarding the commissioning of lighting equipment and lighting controls, including desired calibration settings, factory pre-sets, field calibration, spares, fine-tuning and aiming, manufacturer field inspection, documentation, maintenance manuals, training, and ongoing commissioning efforts. (See “lighting specifications” on the DDC website). The commissioning plan should include checklists for determining if the lighting installation is meeting the intent of the specifications.
- Ensure that DDC review the CD’s for adequate choices to achieve competitive bidding as well as adequate protection from substitutions that may degrade the quality or performance of the lighting system.

### CONSTRUCTION PHASE RESPONSIBILITIES

- Ensure that lighting substitutions are carefully controlled and minimized. “Equivalent” fixtures may compromise efficiency, glare control, or maintenance. Involve the design team in all decisions relating to substitutions.
- Require comprehensive lighting submittals, including luminaires, lamps, ballasts and controls. Lighting submittals should be reviewed by the architect, the electrical engineer and the lighting designer.
- Request lighting shop drawings early and monitor them closely, to prevent long lead times from becoming an excuse for substitutions. Keep on top of re-submittals.
- Use the checklists in the commissioning plan to determine if the installed lighting system and controls are acceptable.

### COMMISSIONING RESPONSIBILITIES

- Involve the design team and lighting designer in the calibration and aiming of the lighting fixtures and controls. Coordinate with manufacturer’s field representatives when called for in the specifications.
- Verify that the owner has received all “spare” lighting equipment called for in the specifications.
- Verify that the contractor has provided all documentation of calibration settings and all material required in the specifications for the maintenance manuals.
- Verify that the contractor has provided the owner with any training required in the lighting specifications.
- Establish an on-going maintenance program with the building operators, including group re-lamping schedules and cleaning schedules.
- Establish a plan for future verification of calibration settings and aimings, to ensure project continues to perform as intended.
- Although not usually part of standard design services, a comprehensive commissioning process should include the preparation of a report for the owner, supplementing the contractor’s O&M manual. This report should include an explanation of the systems installed and the design intent, guidance for the cleaning and maintenance of the system, and recommended frequencies for cleaning, relamping, re-calibrating and re-evaluating the lighting system components. This scope is typically contracted for as a separate fee.
- Independent commissioning agents are becoming more abundant as green architecture becomes more prevalent. However, since commissioning originated with mechanical systems (and is often thought to be limited to HVAC), commissioning agents are typically mechanical engineers. While commissioning agents offer the advantage of a fresh, independent look at the lighting, it is also possible that commissioning agents will be less knowledgeable about the details of the lighting controls than the specifier of the system. Unless the commissioning agent has a great deal of expertise in the types of daylighting or electric lighting controls proposed for the project, the designer of the controls systems should be explicitly contracted to participate closely in the commissioning process.



Lipper & Co. office, New York, New York

photo: Dub Rogers courtesy: Gruzen Samton

## DESIGN TEAM — STRATEGIES

The goal of this DDC Lighting Manual is to promote lighting systems that are “energy effective”, that is those that conserve energy while meeting all appropriate standards for lighting quality. Lighting quality includes such considerations as visual comfort, glare control, uniform distribution, lighting of walls and ceilings, color rendering, and the absence of harsh patterns, shadows and flicker. A successful lighting design requires that both the quality and quantity of light be balanced, while conserving non-renewable resources. Strategies that are specific to certain space types can be found in the Application Briefs. These space types include office, library, adult detention, warehouse, workshop, corridors, stairs, toilets, and building exteriors.

### SUMMARY

#### ENERGY EFFECTIVE LIGHTING DESIGN STRATEGIES

- A) Integrate lighting into the total design process from the beginning.
- B) Consider daylighting as a primary lighting design component.
- C) Reduce lighting needs by improving the visibility of the task, clustering similar functions, reducing obstructions, reducing absorption, and avoiding glare.
- D) Use efficient lighting equipment to reduce connected loads. Design acceptable quantities and quality of light so that occupants do not feel the need to “fix” the system, (by shielding fixtures, bringing in table lamps, closing blinds) resulting in an increase of energy consumption.
- E) Specify energy and quality performance of lighting equipment, so inappropriate substitutions will not degrade the intended results.
- F) Use lighting controls such as occupancy sensors and daylight harvesting to reduce intensity or duration of lighting use and reduce energy consumption. Design user-acceptable lighting controls so occupants are not distracted and do not feel the need to override the systems.
- G) Specify and monitor the commissioning of lighting and control equipment, including fine tuning, aiming, calibration, documentation, training, and operation and maintenance manuals.

- Zone the building so that open areas at the perimeter allow light to penetrate to closed spaces within. To optimize daylight access to occupants, it is preferable to locate open offices at the perimeter and closed offices inboard with clerestories, etc. However, if offices must be located along the perimeter, consider using interior clerestories, transparent doors and/or skylights.
- Evaluate and treat each façade separately. Reduce east and west exposures. Long rectangular-shaped buildings (2:1) with more wall and window area on the south and north, if detailed correctly, are most energy efficient in the NYC climate zone. Window to wall ratios of 30% to 40% on the north and south facades are typical for daylighted buildings in this area. A building oriented due South, or slightly east of south performs best.
- High Ceilings and horizontal windows located high on the wall distribute daylight more effectively than vertical or punched windows. The tall win-

## LIGHTING QUALITY STRATEGIES

### INTEGRATE DAYLIGHTING EARLY IN DESIGN

While detailed daylighting design is beyond the scope of this Manual, every consideration should be made to include daylight in the design. Wherever possible, consider natural light as the primary source of light, and electric lighting as the “supplemental” source. Not only is natural light an abundant renewable resource, we desire the connection to the out-of-doors for both its informational content (time of day and weather) and for its dynamic changes on a daily and seasonal basis. Daylight provides an opportunity for higher light levels than electric lighting, which may stimulate the daily rhythms that affect sleep and mood. The real estate market reinforces the desirability of a windowed workplace, and studies have shown improvements in student performance in daylighted schools. Some recommendations for windows and daylighting are outlined below.

- Integrate daylighting with a building’s shape and orientation on its site, climate, landscaping, fenestration and mechanical systems.
- Use narrow floor plates to allow daylight to penetrate to the interior. Plans that are simple bars or ‘L’ or ‘H’ shapes, or buildings with atriums or courtyards enable natural lighting of most interior spaces because they allow large floor areas to have narrow floor plates.

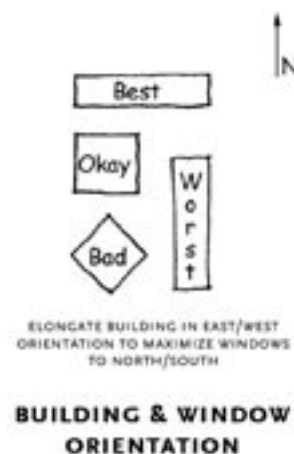

dows of historic buildings allowed the daylight to penetrate into the space, but the wide walls between the windows, resulting from the bearing-wall construction, may require compensatory wall washing to alleviate contrast.

- Consider separating the windows used for view from the windows used for daylighting, so that the daylight windows can be located at the top of the ceiling, without exceeding a reasonable window to wall ratio. A good strategy is to limit the glazed area to only what is required for daylighting and an adequate view. Excessive glazing will increase heating and cooling loads.
- Shield direct sun penetration from work areas to prevent glare, heat gain and thermal discomfort. External sun control devices are vastly more efficient than interior blinds or shades, because they stop the solar energy before it hits the glass, reducing cooling loads on the interior. However interior shades are recommended for glare control and to stop sun penetration at the lowest sun angles. Horizontal overhangs, blinds and louvers are most effective on the south facing façade. Vertical fins, blinds and louvers are required on the east, west and occasionally the north facades. In addition to the undesirable heat gain, blocking the sun on the east and west facades usually requires blocking the view, as well.
- Overhangs are most effective on the south side of a building, to block the high-angle summer sun. It is generally impractical to have them extend out more than 75% of the height of the window. In the NYC area, an angle of 55 degrees between the bottom of the window and the outer edge of the overhang will protect the window at least until September 1. An angle of 50 degrees is necessary to protect the window until the equinox (September 21), which is the end of the overheated period in this region. Many designers erroneously use the highest angle of the summer sun on the June 21 solstice (about 72 degrees) to design an overhang, but the results will be too shallow to be effective for the rest of the summer.

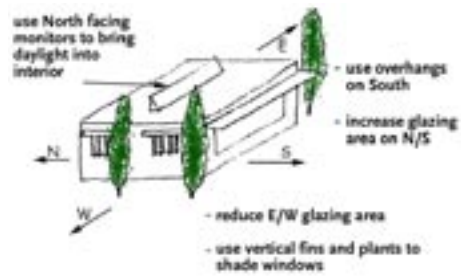

**EXTERIOR SUN CONTROL**

## INTEGRATE DAYLIGHTING EARLY IN DESIGN

- Provide higher ceilings to increase daylight penetration. Consider HVAC distribution systems that allow higher ceiling heights (e.g., hydronic rather than all-air) thus increasing daylight penetration. If utilities and ductwork result in lower ceiling heights, raise the ceiling to the top of the windows at the building perimeter, and keep ductwork, wires and cables on the interior. Slope or step the ceiling down from the perimeter, but try to maintain the highest ceiling for at least 12-15 feet from the window wall, to establish a daylighted zone where electric lighting can be reduced.
- Light shelves can be located inside or outside of windows and are effective for distributing the light deeper into the space, resulting in greater uniformity of daylight for ambient lighting purposes. Light shelves also block some of the sky glare for occupants close to the windows, and can block direct sun penetration on the lower view windows. They are most effective on south facing windows, followed by north-facing windows. Exterior light shelves are more effective for controlling solar heat gain, but interior light shelves are appropriate for existing buildings or north-facing windows.
- Skylights can bring daylight deep into interior spaces on the top floor or one-story buildings. Low-e glazing assemblies should provide adequate U-values for the NYC climate. Prefabricated units and high curbing considerably reduce the chances of water leakage. Diffusing glass or acrylic reduces heat gain and the potential for overly bright sun patterns.
- Monitors facing north are the most effective form of “top-lighting” because their light is more uniform throughout the day. In addition, sun penetration, heat gain, heat loss and snow cover have much less of an impact on monitors than skylights.
- Clerestories, or windows above eye-height, are effective windows to bring daylight deep into the space in areas where view windows are not possible or desirable, such as storage spaces or locker rooms.
- Select high-performance glazing assemblies that combine better thermal control, Solar Heat Gain Coef-

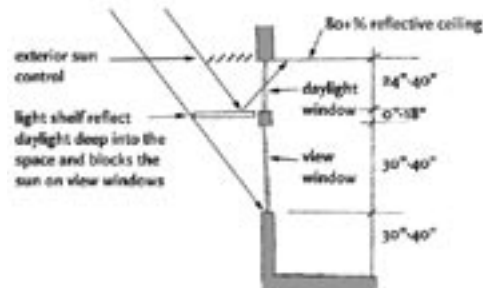

**WALL SECTION FOR DAYLIGHTING**

ficient (SHGC), with higher visible light transmittance (VLT). VLTs much below .35 are noticeably tinted to the occupants, and should be used with caution. VLTs from .60 to .70 may be necessary for daylighting schemes, and should be used for daylight windows (above 6'-0") and for clerestory windows.

- Avoid window glare. Use the lightest color finishes adjacent to windows. Provide blinds, shades or curtains where required. Splay the openings of skylights (and windows in deep walls) to create a gradation of light and soften the contrast between the opening and the adjacent surfaces.
- Minimize interior obstructions. Lower and light-colored interior furniture partitions, files and shelving increase the efficiency of the daylighting (and electric lighting) design.
- Use light-colored matte or eggshell finished materials throughout the space. This decreases absorption of the light and increases interreflections and efficiency of the daylighting (and electric lighting) design.

## COORDINATE DAYLIGHTING WITH ELECTRIC LIGHTING

- Design electric lighting to complement the daylight direction and distribution. Consider control strategies when designing the electric lighting system (i.e., orient fixtures parallel to the window wall so they can be dimmed or switched in response to the daylight distribution).

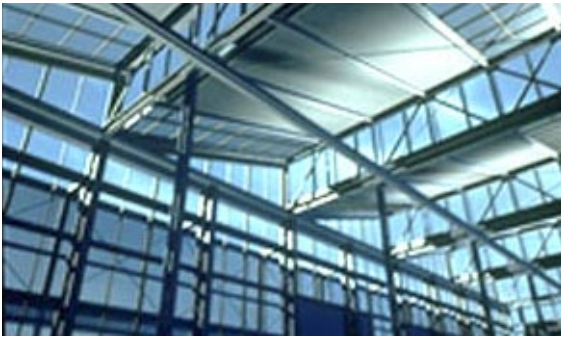

courtesy: The Smith Group

Fluorescent lights located below the monitor windows reinforce the architecture in the evening.

gies when designing the electric lighting system (i.e., orient fixtures parallel to the window wall so they can be dimmed or switched in response to the daylight distribution).

- Save energy consumption by controlling electric lights. Daylight is a desired amenity in most interior spaces, but does not save energy unless the lights are dimmed or turned off when daylight is available. This is called “daylight harvesting”. To be successful, high-performance glazing is generally required so that the reductions in the electric lighting loads will offset any increase in thermal loads.

- Use dimming ballasts whenever economically feasible. Dimming in relation to daylighting not only saves more energy but is far less distracting to occupants than multiple-level switching.
- Multiple level switching in response to daylight (sometimes called “stepped dimming”) is a reasonable solution in spaces without full-time stationary occupants, or when the distraction will not have a serious negative effect, or where the switching is only expected to occur at the beginning or end of the day. Warehouses, atria, dining rooms, lobbies, corridors and elementary school classrooms are typical candidates for daylight switching.
- See References for design guidance for daylighting and control systems.

## PROVIDE APPROPRIATE UNIFORMITY FOR THE SPACE’S FUNCTION.

The human eye does not see the illuminance falling on the work surface, but rather responds to “luminance”, the light that is reflected off of surfaces. The human perception of luminance is “brightness”, so brightness will be used interchangeably with luminance in this document. Most recommendations for lighting uniformity are in the form of “luminance ratios”. Luminance is a function of the illuminance on the surface, the reflectance characteristics of the surface, and the angle of view. (See glossary) Consequently, if the same amount of light (illuminance) falls on two adjacent surfaces (one white, one navy) the lighter colored surface will appear brighter since it is reflecting more light than the darker surface. Even if the same number of footcandles (illuminance) hits the surfaces, the luminances will be quite different. The difference between the two surfaces is called the luminance ratio or brightness ratio. A large contrast can disrupt the ability of the eye to adapt comfortably and cause glare. Luminance ratios are very important for lighting quality, but are time-consuming to calculate. Computer lighting software typically provides “exitance” ratios, which are acceptable because exitance is the same as luminance except it assumes a totally diffuse (matte) surface rather than dealing with the angle of light reflections. Illuminance (footcandle) ratios can be used in lieu of luminance ratios ONLY if all the surfaces under consideration have similar reflectances i.e., if they are within + 10% of each other.



Some recommendations regarding luminance ratios:

- Determine the appropriate luminance ratio for the task. The Illuminating Engineering Society of North America (IESNA) gives recommendations for various lighting applications. Typical luminance ratios (minimum to maximum) for reading tasks are: 1:3 or 3:1 between the task and the immediate surrounds the task surface, 1:10 or 10:1 between the task and non-adjacent surrounds, and 1:20 or 20:1 the brightest or darkest surface in the field of view. See Application Briefs for situations where these luminance ratios do not apply. Experienced lighting professionals are familiar with which designs meet these standards, but these ratios can be verified by manufacturer's calculations or software programs.
- A 3:1 or 1:3 ratio provides enough variation to achieve desirable three-dimensional modeling of faces and objects for most tasks. Higher contrast is desirable where modeling is the primary function of a space, as in museums or retail. Modeling is enhanced by increasing the proportion of directional lighting to generally diffuse lighting. (See luminaire distributions in the glossary).



photo: Hayden McKay

Direct sunlight creates an unacceptable level of brightness and contrast in a work environment.

- Do not exceed the recommended spacing of selected lighting fixtures by placing them too far apart. Exceeding the recommended Spacing Criteria (SC) will result in uneven distribution of light on the working plane (e.g., desk tops). If lower design light levels are required, this can be achieved by using more fixtures with fewer lamps, lower wattage lamps, dimming or reduced output ballasts. Space fixtures more closely if there are partial height furniture partitions, (especially with overhead shelving or bins), library stacks, storage shelving or any vertical obstructions that would inhibit the distribution of light. (See graphic in Glossary). The spacing Criterion (SC), is defined as the maximum spacing of a particular fixture for

a given mounting height. Spacing Criteria values are published on manufacturers' product sheets, and may have different SCs for spacing parallel or perpendicular to the lamps.

- Avoid obvious shadows (especially near machinery) and harsh patterns. Avoid totally directional light or sharp cutoff distribution luminaires.

### INCREASE ROOM SURFACE LUMINANCE AND REFLECTANCE

A lighting system that provides light from many different directions is more comfortable than one where all the light is directed straight down, and people perceive spaces to have more light if the walls and other vertical surfaces are lighted.

- Distribute light toward walls, ceilings and furniture partitions in rooms with full-time occupants. Directing at least 15 fc toward walls will keep most spaces from appearing too dim. Walls less than 70% reflective will require more illumination to achieve the same effect.
- Increase room surface reflectances: Use light colored finishes on ceilings and all vertical surfaces above the working plane, typically 30" above the floor. (See graphic, right). For most space types, strive for a minimum reflectance of .80 for ceilings and .70 for walls and vertical surfaces above the working plane.
- Consider ceiling tiles with reflectances of approximately 0.9, for use with luminaires directing most of their lights upward.
- DDC requires that reflectances of all major wall, ceiling and furniture surfaces be documented during the design development stage, for use in lighting calculations. A "reflectance" column should be added to all interior finish schedules. Reflectance values are available from manufacturers of paint, furniture and most interior finishes.

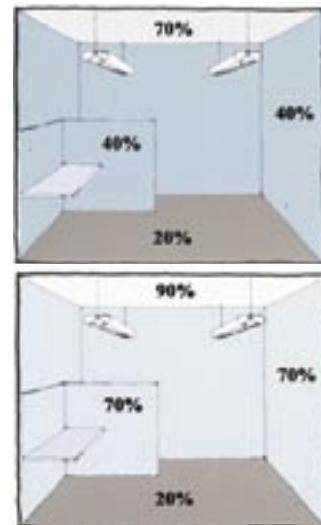

A small increase in room reflectances produces a big improvement in efficiency. The lighter room provides 55% more light on the task for the same energy. It would require 70% less energy to provide equivalent brightness in the lighter room. The lighter colored room also provides better brightness ratios, comfort and daylight distribution.

Credit: Courtesy DesignLights Consortium

## AVOID GLARE

Glare occurs when bright light sources interfere with the viewing of less bright objects. The contrast may be uncomfortable or even disabling. “Direct Glare” is caused by fixtures located in front of viewers. “Reflected Glare” and “Veiling Reflections” are caused by bright reflections in surfaces such as glossy paper or computer screens. “Overhead Glare” is caused by fixtures directly overhead. (See illustration below).

- Shield the lamps from view with baffles, louvers, lenses or diffusing overlays.
- Be careful in the use of so-called “low-brightness” specular (mirror-like) reflectors, which can cause a distracting sensation of “flashing” as viewers move their heads or walk through a space. This may be acceptable in a retail environment, but not in an office or school setting.
- Reduce lamp glare by using lamps of lower brightness, e.g., in offices, lamp brightness should be no greater than a standard T8. Use more fixtures if necessary. Carefully consider lamp glare when using high output ballasts (e.g., above .90 BF).
- T5 and T5HO lamps greatly exceed the brightness of a bare T8 lamp, so particularly in offices, they should be used only in coves or indirect applications or with lenses or overlays, where the lamp is not visible from any angle or is heavily baffled.
- In offices and similar space types, reduce overall luminaire brightness and increase efficiency by using no more than three (3) T8 lamps in 2' x 4' fixtures.
- Increase the reflectances of the room surfaces.
- Light the surfaces around the light source with daylight or indirect lighting, to reduce contrast.
- Avoid shiny materials, especially in view of stationary workers: Even the upper reflectors in open-bottomed luminaires should not be specular (mirror-like). In addition to creating overhead glare (see sketch, right) specular reflectors and louvers can create a cave effect (dark upper walls) and/or harsh patterns on walls and/or sharp shadows under shelves and overhead bins. To counter these effects, select only semi-specular or white painted louvers. Specular reflectors may be used when concealed above lenses and overlays. In applications with high ceilings, such as workshops, warehouses, and retail, the tolerance for glare and specular materials is greater.

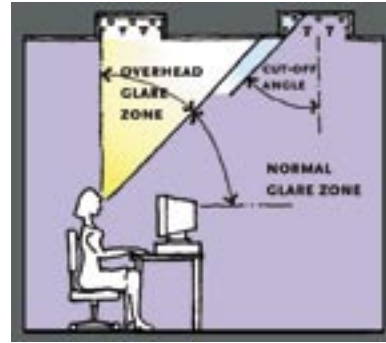

Bare lamps and shiny louvers and reflectors can cause glare above the worker, called “overhead glare”

Credit: Courtesy DesignLights Consortium

## PREVENT LAMP FLICKER

Some people are very sensitive to the low frequency lamp flicker caused by 60 Hz magnetic core-and-coil ballasts for fluorescent and HID sources.

- Specify electronic high-frequency (20,000 Hz) ballasts (which have now become standard) and have the contractor replace the ballast in any fixture that shows obvious signs of lamp flicker.

## SPECIFY APPROPRIATE COLOR LAMPS

There are two common metrics to help specifiers evaluate the “color” of a lamp. The Color Rendering Index (CRI) describes how a well lamp’s color spectrum is likely to reveal the color of the objects it lights, with higher CRIs denoting better color renditions. The Correlated Color Temperature (CCT) describes the appearance of the lamps themselves in terms of warmth or coolness.

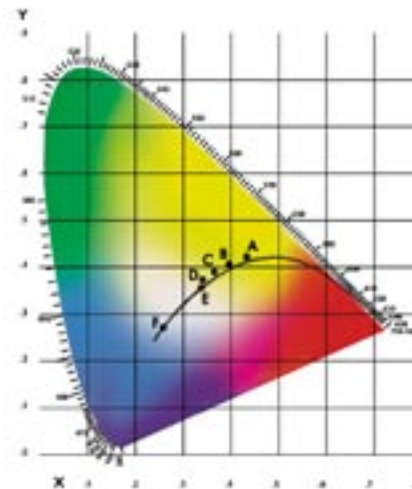

Correlated Color Temperatures for lamps: A) 3000K, B) 3500K, C) 4100K and E) 5000K, D) Sunlight at noon, 4870K, F) NW sky 25,000K.

Courtesy: Philips Lighting

- Specify appropriate color rendering lamps for the space function: Fluorescent sources currently have CRIs of 70 to 98 (out of possible 100). Lamps with a CRI of at least 84 are required by DDC. They improve the appearance of people and objects in the space, and the lamps produce more lumens per watt than lower CRI lamps, but they are slightly more expensive. Lamps with a CRI above 90 may be appropriate for some specialized applications such as retail, showrooms or design studio spaces, but are often more expensive, and may provide fewer lumens per watt. High color-rendering metal halide ceramic-coated lamps are available for interior applications, such as accent lighting or in high spaces.
- Specify an appropriate color temperature for lamps: Commercial fluorescent sources are commonly available in a range of CCTs from 2700 (warm) to 6500 Kelvin (cool). These correspond roughly to the range of incandescent to daylight color temperatures. Color temperatures most commonly used for commercial applications are 3500 K and 4100K. It is not necessary to match the color temperature of electric light sources with the cooler color of daylight. The colors of materials used in the building should be evaluated under both sources. There is some evidence that higher color temperatures (5600 to 6500 Kelvin) coupled with higher CRIs can produce better visibility, but this has not gained universal acceptance. Among other ongoing research in this regard, DDC is conducting an experiment in conjunction with the Lighting Research Center. See the Technologies section for more detail about color.
- Understand the lamp codes: Fluorescent lamp color is described by a three-digit ANSI code such as 835 or 741. The first digit represents the CRI and the second two digits represent the correlated color temperature. Thus 835 indicates a CRI of 80 to 89 with a CCT of 3500 Kelvin. See page 88.

## ENERGY EFFICIENCY AND DESIGN STRATEGIES

### EVALUATE VISUAL TASKS AND SUGGEST IMPROVEMENTS

More light is needed to perform difficult visual tasks, but often the task visibility can be improved by other means, thereby saving energy. Examples are given in the various application guides herein. For spaces in which the tasks are fairly predictable, such as office areas where forms are processed, changing the media could increase worker comfort and save lighting energy. Task visibility can be improved if you:

- Increase the contrast (e.g., black on white or white on black rather than low contrast gray printing on colored background).
- Decrease shiny or glossy finishes which make tasks subject to a loss of visibility caused by “veiling reflections” (e.g., printed materials on glossy paper or labels covered in shiny acetate sleeves).
- Increase font point size or boldness. Increase spacing between rows of print.
- Use ALL CAPS for heading or titles, and a combination of upper and lower case for text. Some font styles are easier to read than others. Serif typefaces are generally easier to read than sans serif for dense text.
- Locate visual tasks closer to the viewer’s eye position.
- Use color coding where appropriate, for sorting, filing or storage tasks, or for accentuation or safety purposes.

### PROVIDE LIGHT WHERE IT IS NEEDED

- Select appropriate light levels. The highest light levels are not always necessary if the viewer is not constrained by time, the speed and accuracy of task performance is not important (e.g., leisure reading versus reading medical charts,) or the viewer is young with normal vision.
- Group similar tasks together when similar light levels are needed.
- Position the lights carefully in relation to the task and viewer, to avoid veiling reflections and body shadows.
- Provide lower levels of uniform, ambient light (daylight or electric) and provide local task lighting to make up the difference. For most work spaces with full-time stationary occupants, the ambient level should not drop below 25 footcandles or it may be perceived as too dim. Walls and ceilings should be lighted by the ambient system or by supplemental luminaires.
- Balance the task and ambient lighting levels. The light levels supplemented by the task lighting should be no more than two times the light levels supplied by the ambient overhead system. For exhibit or display functions, this ratio can increase to 3-4 times task versus ambient. Office lighting designs that provide 30 fc ambient can be supplemented by an adjustable task light that can provide an additional 20 to 40 fc on the task and be within acceptable luminance ratios.

- Provide articulated desk lamps that move in three planes and allow the occupant to accurately light the task, adjusting the location of the source to the tasks, rather than using under-cabinet lights for task lighting. If the undercabinet light is in front of the user, specify special “bat-wing” distribution lenses, to redirect light to the sides. The light directed toward the viewer is likely to provide “veiling reflections,” a form of glare that obscures the task by putting a veil of light over it, reducing the contrast between the print and the background.
- For undercabinet luminaires, utilize low-output (.30-.50 BF) ballasts (i.e., hardwire the lower level of a two or three-level ballast) because full output of a T8 or T5 lamp usually creates too much contrast and unnecessarily consumes energy. Under-cabinet lights are useful for filling in harsh shadows under shelves and bins, so use of a 4’ long fixture at low output provides greater coverage and comfort than a 2’ long fixture at full output.

## SELECT THE RIGHT ENERGY EFFECTIVE EQUIPMENT

An “energy effective” strategy is one that conserves energy while meeting all appropriate standards for lighting quality, so the most efficient fixture is not always the best selection. A building-wide approach can best reduce your energy consumption.



courtesy: Cruzen Samton

High-reflectance surfaces increase uniformity and comfort.

- Determine the lighting approach for functional and qualitative requirements of each space, before selecting equipment.
- Select a luminaire distribution and light source that best fits the application. Then choose the most efficient luminaires within that category.
- Specify minimum efficiencies as well as qualitative performance, such as glare shielding. Otherwise the specification may be met by a highly efficient but glarier luminaire. See sample luminaire descriptions in each of the Application Briefs.
- Use lamp/ballast combinations which provide more lumens per watt (i.e., have a higher “efficacy”). See efficacy chart in the Overview and in the Technologies section. Efficacies that are calculated by lamp data alone, without considering ballasts, can be misleading.
- “High-performance” 4’ long T8 fluorescent lamps should be used for most DDC projects, because they provide more lumens per watt than standard T8 32W sources. They come in two versions, lower wattage (28-30 W) or higher output (3100+ lumens). When the lamp is exposed or used in open-bottomed or parabolic luminaires, use the lower wattage version or combine a high output lamp with a reduced output ballast (.77 BF) to achieve high lumens per watt with comfortable overhead luminances. Either option is more efficient than a standard T8.
- T5HO lamps with ballasts do not have as high an efficacy as T8 sources, but may be the best choice for the reflector system in an indirect or wall wash luminaire. See fluorescent efficacy comparison in the technology section.
- Avoid using high lumen output lamps in exposed fixtures, since they are prone to overhead glare when mounted below 12’. Only use T5 lamps (standard and high output) in indirect or totally shielded luminaires.
- Use fluorescent lamps that maintain a higher percentage of their light (90% or higher) over their rated life. See maintenance curves in the technology section.
- Specify factory pre-setting of ballast output, aiming angles, socket positions, etc., to the greatest extent possible. This will decrease dependency on the calibration by the contractor, and will guarantee some energy savings, even if they are never field adjusted.

## PROVIDE ACCURATE CALCULATIONS

- Calculate and document the energy code criteria for the project. Keep track of connected load and controls throughout the design phases. Demonstrate and document compliance with selected codes, and submit DDC form in Appendix B with back-up.
- Work from documented and agreed-upon reflectance values for room surfaces, to determine light levels (illuminance).
- Use correct light loss factors in illuminance calculations (see Technologies section). A commitment by the building owner to proper lighting maintenance procedures will avoid wasteful over-design of the initial lighting system.
- Take obstructions into account in calculations, especially partial height furniture partitions, library or warehousing shelves, file cabinets or other obstructions to electric lighting. The IESNA Handbook has a recommended procedure for calculating partition losses. Also include factors for losses from ductwork or piping obstructions which may reduce daylight or electric light distribution.
- Re-evaluate the lighting if the light levels exceed the target levels by more than 10-15 % in large spaces, to avoid wasting energy. In small spaces, light levels may exceed the target by as much as 25% if, for example, three lamps are too few and four lamps are too many. Consider variables such as re-spacing of fixtures, lamp types or number of lamps per fixture, ballast output, luminaire distribution and control options. If lighting quality is carefully considered (lighted walls and ceilings, glare control, high reflectance surfaces, comfortable luminance ratios) maintained light levels can be 10-15% below target levels and still be acceptable.

## INCORPORATE LIGHTING CONTROLS

While only the energy conserving features of controls are discussed below, it should be noted that lighting controls are also valuable tools for creating visual comfort, flexibility of functions and a sense of user control, which in turn contributes to occupants' satisfaction with their environments and jobs. Lighting controls cover a broad range of sophistication from multiple-level or zoned switching, timed controls, and occupancy sensors to daylight dimmers, programmed presets and DALI systems.

- Design lighting controls that are user-acceptable. Avoid controls that are frustrating or distracting to occupants, as they are likely to be sabotaged.
- Work closely with several control equipment manufacturers during the design phase, so you are convinced that their products will meet the design intent.
- Describe the design intent, performance criteria and calibration setting of the control systems in the specifications.
- Provide for clear labeling of all equipment in the specifications, and follow up during the construction phase.
- Set initial calibration levels in the specifications or during the shop drawings phase. Specify that equipment be factory pre-set to the greatest extent possible. While this does not eliminate the necessity for proper field calibration, it saves time during construction and commissioning, and increases the likelihood that the controls will function as intended.
- The greatest energy savings are achieved with manual-on, automatic-off occupancy sensors, especially in daylighted spaces.
- Consider going beyond the minimum control requirements of the NYS Energy Code or Standard 90.1, by providing more discrete levels of switching controls. Specify luminaires with multiple lamps to be factory-wired for two- or three-level switching. The objective is to have multiple levels of light uniformly distributed. Linear luminaires with two side-by-side lamps can be specified with "in-line" wiring, so that a ballast connects all the lamps in a line (on one side of the luminaire) rather than both lamps side to side. This way each row of lamps can be switched separately. Three-lamp luminaires are typically wired in an "inboard-outboard" configuration, so that the single middle lamp is switched separately to provide



photo: Hayden McKay

Design lighting in multiple layers, and control each layer or luminaire type separately.

33% of light, the two outer lights are switched separately for 67% light. In some applications (like classrooms), this would be an either/or choice, and in other applications, it would be possible to have all three lamps on simultaneously. Avoid switching luminaires in a checkerboard patterns. Avoid non-uniform switching patterns, unless distinct areas of a large space are used at different times and the resulting appearance is not chaotic.

- Control zoning: The energy codes stipulate minimum areas for lighting control zones. The design team should consider whether even smaller breakdowns of control zones would be energy effective, depending on the appropriate technologies and functions of the space. Separately zone the lights near the windows to utilize daylight. Zoning for specific activities in multi-purpose spaces is a common practice. Luminaires designated for night-lighting, or emergency lighting, or cleaning lights, should be separated into zones that can logically be controlled, in order to avoid unnecessary energy consumption.
- See the specifications section on DDC website for suggested language related to lighting controls.

## **EMERGENCY LIGHTING, NIGHT LIGHTING AND SECURITY LIGHTING DESIGN STRATEGIES**

Often, the same lighting fixture locations may be ideal for emergency, night-lighting and security lighting purposes. However, these three functions, and their operating schedules, should be considered independently, so that the best system of luminaires and controls can be designed to ensure safety and energy efficiency. Emergency lighting must meet stringent codified criteria for emergency egress when the building is occupied. Night lighting provides minimal lighting during generally unoccupied periods, to allow safe passage through unoccupied spaces or to provide access to light switches or areas controlled by automatic occupancy sensors. Security lighting provides illumination for security personnel or cameras, and may operate intermittently or continuously, depending on the continuity of surveillance.

### **EMERGENCY LIGHTING**

Emergency luminaires are those designed to operate when there is an interruption in normal building power. They are often selected from the luminaires providing the general building illumination. In addition to meeting all relevant codes and standards, emergency lights should be located and aimed to orient the occupants to the most direct paths of egress, with the least amount of confusion and glare. Most commonly, emergency luminaires receive emergency power directly from a circuit breaker panel that is connected to an emergency generator, or are powered by individual emergency ballasts. Even if the building does have an emergency generator, DDC may request that some emergency lights also be specified with individual emergency ballasts. These emergency ballasts are designed to operate the lamps for an acceptable length of time, until the building can be vacated and searched, or until normal power is restored. Red-colored testing buttons demonstrating that the emergency ballasts are fully charged, must be visible for inspection from the floor. In the case of custom decorative luminaires, it is often acceptable to locate the testing button in a remote, but visible location. If emergency lights are used for normal space lighting, any controls that dim them or turn them off (for daylight harvesting, pre-set scenes, dimming, etc.) must be wired in such a way that the luminaires revert to full operation in case of a loss of power. Manufacturers of lighting or dimming controls can assist the design team in achieving this configuration. Emergency lights should be capable of achieving the required light levels immediately (in less than ten seconds) after a loss of power. Metal halide or some high pressure sodium lamps may not be able to meet this criterion, so should be specified with auxiliary lamps (typically quartz-halogen) that will initially provide the necessary light level until the primary light source warms up or re-strikes, at which time the auxiliary lamp is automatically extinguished.

### **NIGHT-LIGHTING**

A night lighting system serves several functions in buildings. It allows the first few occupants in the morning or the last few occupants after hours to safely navigate circulation paths in a familiar building until ambient lights can be manually turned on or off. It allows cleaning crews or security personnel to move from area to area without leaving all the lights burning in between. Finally, it allows fire, police, or other

emergency personnel to find light switches in an unfamiliar building. This can generally be accomplished by activating only a few luminaires for a short amount of time. Night lighting should be designed to prevent energy waste by a careful examination of the true needs for after hours lighting. Some combination of dawn-to-dusk operation only of lights at entry doors, combined with low-level lighting activated by occupancy sensors, should be considered.

## SECURITY LIGHTING

Security personnel can often use the night lighting system to move around a facility, and activate higher levels of lighting only when it is necessary. Security lighting should operate continuously only if the space or camera images of the space are directly and continuously viewed, and immediate action can be taken. Otherwise, lights associated with security cameras can be controlled by occupancy sensors, so that both lights and cameras are activated by an intruder.

## OPERATIONS AND MAINTENANCE STRATEGIES

### DESIGN WITH MAINTENANCE IN MIND

- Minimize the number of different lamp types on a project.
- Avoid specifying lamps that are likely to be mis-installed. For example, avoid using two colors or wattages of fluorescent lamps of the same length, or two beam-spreads of reflector lamps of the same size or wattage.
- Specify recessed open-bottomed luminaires with top ventilation slots. The fixture will stay cleaner than with an unventilated housing.
- Without sacrificing efficiency or quality, reduce the number of different manufacturers or components.
- Specify minimum performance criteria for the sturdiness of housing, the quality and durability of the finishes, especially interior surfaces used to reflect the light, easy access to ballast compartment, captive fasteners, hinges, safety chains and the like.
- Document calibration criteria, so that it becomes part of the permanent record for long-term maintenance and adjustment.
- Require adequate documentation from the contractor, in the form of as-built equipment sheets, lists of lamps and ballasts, calibration instructions, troubleshooting guides and adequate staff training. See Specifications on DDC, Office of Sustainable Design website ([www.nyc.gov/buildnyc/ddcgreen](http://www.nyc.gov/buildnyc/ddcgreen)) for suggested language.
- Ensure that the commissioning agent or other designated party accepts responsibility for delivering each of the above items.

### COMMISSION THE LIGHTING SYSTEM

Calibration and Commissioning of lighting controls is essential, for proper operation and to capture the potential energy savings. Even if no other part of the project is commissioned, lighting controls must be properly calibrated and documented.

- Commission the lighting system before occupancy. All lighting controls must be calibrated and commissioned after furniture is in place but **prior** to occupancy. This is a very small window of time. Even a few days of occupancy with poorly calibrated controls can lead to permanent overriding of the system, and loss of all savings.
- Calibrate and recheck. Most photosensors require both a daytime and nighttime calibration session.
- Calibrate daylight dimming and switching systems for the specific conditions, to minimize distractions and ensure user acceptance. Occupants expect a daylighted space to be brighter. Consequently, the calibrated footcandle settings for a daylighting system are set higher than the footcandle levels intended for the electric lighting alone. See technology section for guidance.
- See suggested Specification text on the DDC website related to lighting commissioning, including calibration, aiming, documentation, training and operation and maintenance manuals.



Calibrating a Photosensor

courtesy: The Watt Stopper

The image shows a modern interior space. A large, vibrant orange wall dominates the upper portion of the frame. A small, square window with a dark frame is set into this wall. Below the orange wall, a section of the wall is covered in large, rectangular, light-colored stone tiles. The floor is also made of similar stone tiles. In the background, a glass railing is visible, suggesting a mezzanine or upper level. The lighting is soft and even, highlighting the textures of the wall and floor.

SPACE TYPES-  
DESIGN BRIEFS



## OFFICE DESIGN BRIEF

The NYC Department of Design and Construction (DDC) manages the construction and renovation of NYC's municipal buildings, most of which contain some office spaces. These guidelines cover typical open plan and private offices, as well as meeting rooms with video-conferencing.

### LIGHTING QUALITY AND QUANTITY STRATEGIES

Offices have specific considerations because of their function and spatial characteristics. Please review and use the guidelines below, in concert with the basic issues of lighting quality and design strategies set forth earlier in the Design Team Strategies section of this manual.

### OFFICES—SPECIFIC LIGHTING QUALITY AND QUANTITY ISSUES

ISSUE	IMPORTANCE
Direct and Reflected Glare	Very Important
Daylighting Integration and Control	Very Important
Luminance of Room Surfaces	Very Important
Appearance of Space and Luminaires	Very Important
Relationship between light source, visual task, and viewer	Very Important
Color Appearance (and Color Contrast)	Important
Flicker	Important
Light Distribution on Task Plane and Room Surfaces	Important
Modeling of Faces or Objects	Important
Shadows	Important

From The IESNA Lighting Handbook, 9<sup>th</sup> Edition.



photo: Dub Rogers courtesy: Gruzen Samton

Light hitting the task from many directions reduces contrast and glare.

#### Direct and Reflected Glare Control

Both direct and reflected glare can be distracting to workers and increase the difficulty of visual tasks, potentially resulting in a loss in productivity. Office workers at fixed workstations are particularly affected by direct and reflected glare from luminaires and windows, because they can't easily move their relationship to the computer screen or light sources. Improvements in computer monitors have reduced the problem of reflected screen glare, but black backgrounds such as CAD drawings are still prone to reflected images. Under-cabinet lights located in front of flat paper tasks are often the source of veiling reflections (reflections on the task surface that

mask the information that lies behind), and so are not the preferred source of desktop illumination. Overly bright luminaires or exposed lamps can create overhead glare, even from a luminaire that is above the normal field of view.

#### Daylighting Integration and Control

A building can be designed to provide high levels of relatively uniform ambient light for offices from natural daylight. Windows offer views and a desirable connection to the out-of doors, with an added benefit of providing the eyes with distant objects for visual focus, allowing them to relax from close-up work. Sun

patterns anywhere in the field of view can create harsh contrasts that are distracting and may be visually disabling, so direct sun penetrations should be avoided in office workspaces. This can be done by using blinds, louvers, overhangs, light shelves, etc.

### Luminances of Room Surfaces

Lighting the walls and ceilings is just as important as lighting the task. The proper lighting of the space contributes to the adaptation level of the eye, mitigates glare, and reduces shadows – all of which improves visual performance. In addition, well-lighted room surfaces provide a more pleasant, brighter-looking and stimulating workspace, contributing to long term work performance and employee satisfaction.

### Relationship between light source and visual task and viewer

The geometry between the viewer, the task and the luminaire determines the presence of both direct and reflected glare. Luminaires with strongly directional characteristics must be geometrically fixed in their relation to viewers in order to avoid glare, and so are not the appropriate choice as the standard fixture in flexible open plan space. Undercabinet lights should not be located directly in front of the viewer, unless fitted with special lenses to reduce veiling reflections. Source brightness must be controlled in open-bottomed luminaires located directly over workers. Computer screens must be located (or be adjustable) to avoid reflections from windows.

### Appearance of Space and Luminaires

The visual hierarchy of surface brightnesses and the layout and style of luminaires strongly influence the character of an office. A balance should be met between the desire for interest and drama, and the need for a productive work environment. Lighting should be designed to aid in orientation of the space and to avoid visual clutter.

### Light Distribution on Task Plane and Room Surfaces

A relatively uniform distribution of light, without strong shadows, is preferred for office environments. Luminance ratios should be fairly uniform. A 3:1 (maximum to minimum) ratio is preferred between the task luminance and its immediate surround. Outside the task areas a wider range of luminances are acceptable, up to 10:1 for surfaces in the field of view and up to 20:1 for the contrast ratio between windows or luminaires and the task surfaces. Shadows under overhead cabinets or shelves can create an excessive luminance contrast, but this can be improved by low-output under-cabinet lights. Totally directional light will cause harsh shadows and generally will not achieve comfortable luminance ratios, therefore a combination of direct and indirect light distribution is preferred.

### Reflectances and Finishes

To achieve the desired luminance ratios and uniformity, reflectances of wall and ceiling surfaces, as well as modular office partitions, furniture and fabrics, should be high. Finishes should be matte or egg-shell. Ceilings should be a minimum of 80% reflectance, with 90% preferred. Walls should be 65-70% reflective and floors not less than 20% reflective. Polished, glossy and shiny surfaces should be avoided because they can be a source of reflected glare. In addition to providing uniformity, high surface reflectances can reduce the amount of light that is needed, thereby reducing energy consumption.

### Color

High color rendering (CRI 84+) lamps with color temperatures between 3500 Kelvin and 4100 Kelvin are preferred for office space functions. In order to limit the number of lamp types on a project, the lamps used in the offices should also be used in ancillary spaces.



courtesy: Gruzen Samton

Light-colored finishes save energy and improve lighting quality.

## No Flicker

An office environment should be free from fluorescent flicker associated with magnetic ballasts. These ballasts are becoming obsolete, and should be replaced in older installations. Newer, high-frequency (20+ KHz) electronic ballasts do not produce flicker. Defective or failing ballasts produce lamp flicker and should be replaced immediately.

## Three-dimensional Modeling

A large proportion of communication in offices is non-verbal. Harsh lighting or solely directional lighting can cause unflattering, unnatural and even confusing shadows. Some proportion of indirect lighting or inter-reflections (light reflected from the walls and ceiling) will allow faces and objects to be adequately modeled. Facial modeling is especially important in meeting rooms and video conferencing spaces.

## LIGHT LEVELS (RECOMMENDED AVERAGE MAINTAINED ILLUMINANCE, IN FOOTCANDLES (FC))

OFFICE TASK	HORIZONTAL FC	VERTICAL FC	LOCAL TASK LTG. TYPE	NOTES
Filing	50	10		
Open Plan Intensive VDT* use	30	5	Undershelf & Task	
Open Plan Intermittent VDT* use	50	5	Undershelf & Task	
Private Office	50	5	Undershelf & Task	
Lobbies, lounges, and reception	10	3		
Mail Sorting	50	3		
Copy Rooms	10	3		
Conference / Meeting Rooms	30	5		
Videoconferencing	30			1

From The IESNA Lighting Handbook, 9<sup>th</sup> Edition

\* Visual Display Terminals (VDT) i.e., computer monitors. Note 1 – Provide vertical illuminance as required for camera.

## DESIGN AND LAYOUT STRATEGIES

### OPEN PLAN AND PRIVATE OFFICES

As a general strategy, provide uniform overall ambient lighting. Use local task light at desks to provide light levels in excess of 30 fc. Ambient lighting that is tailored to the locations of space functions can be more energy efficient than lighting that blankets the space to allow total flexibility. Most private offices can only accommodate one furniture layout, and open plan areas typically have some zones that will always be circulation or filing, and can be treated differently. Work as a team with the owner to reasonably limit the office areas requiring future flexibility. The owner should be made aware that increasingly stringent energy codes may limit the ability of the design team to provide future flexibility in office functions or layouts.

### Fixture selection and location

Pendant direct/indirect luminaires effectively distribute light to the work surfaces as well as the ceiling and walls, achieving a good quality of light for office tasks. By locating the source closer to the task, pendant lights may achieve higher light levels for the energy expended. Pendant mounted fixtures require fewer power feeds and labor for installation than ceiling-recessed luminaires. Since the energy codes are based on the use of suspended direct/indirect luminaires in office spaces, it will be difficult to meet the more stringent updated codes with less efficient luminaire types. Maximize ceiling heights in office spaces, to enhance the effectiveness of daylight and the use of pendant direct/indirect luminaires. The ideal distance from the top of a pendant luminaire to the underside of the ceiling is 18", although 12" is still acceptable. Distances less than 9" can still be accommodated with the use of lenses above the lamp to improve the uniformity of the ceiling brightness.

## Task Lighting

Office tasks range in size and complexity, as do the visual capabilities of the viewer. While many office tasks can be performed under lower ambient light levels, other office tasks require higher light levels, as do many workers, especially those over 40 or lacking perfect vision. The most efficient way to provide supplemental lighting for office tasks is through the use of a local task light with its own switch. This allows the worker to determine when it is needed, providing some personal control over the work environment – a feature that almost always improves employee satisfaction. An “articulated” task light (one that is adjustable in three planes – see luminaire specifications) is preferred because it offers each user the flexibility to achieve the best angle, intensity and glare control for each specific task.



photo:

Personal control of task lighting reduces energy consumption and increases employee satisfaction.

## Undercabinet Lighting

The purpose of an undercabinet light is to reduce shadows produced by overhead bins, cabinets and shelves and to balance luminance ratios. A long, linear luminaire works best for this purpose, but the full output of a T8 fluorescent lamp can result in excessively bright surfaces, creating a luminance imbalance. By specifying undercabinet luminaires that are hard-wired to the low output option of a multi-level ballast, 30%-50% of full light output is provided, in a linear configuration, in a way that permanently reduces the connected load. Further, no new lamp types are added to the project. While undercabinet lights can add supplemental light and are often called “task lights” by furniture manufactures, they are generally less effective for task lighting than an articulated desk-top light. If they are located in front of workers, they should be fitted with special lenses or sleeves to redirect the light to the sides thereby reducing veiling reflections.

## Meeting Rooms

Many meeting rooms are used for a variety of activities, and may need more than one lighting configuration. For most meeting functions, including conferencing, teaching and audio-visual (A/V) presentations, it is important to distribute light to the vertical planes, i.e., participants faces and display walls. Lighting solutions that include some diffuse or indirect distribution of light work well in conference rooms. A totally downlighted meeting room will have an uncomfortable proportion of horizontal illumination to vertical illumination, and should be avoided. On the other hand, local task lighting is not usually practical, so some directional down light component should be included for occasions when participants must perform reading tasks. There are many ways to achieve appropriate results, from indirect coves coupled with wall washers and downlights, to pendant fixtures that distribute light in multiple directions. The bottom of pendant fixtures, even if over a table, should not block the visual contact of two persons standing across the table from each other. In addition, pendants should not conflict with drop-down video projectors or other A/V components, or appear in the view of video cameras.

courtesy: Committee on IESNA Lighting for Videoconferencing and Presentation (LVFP)



Recommended illumination ranges for video-conferencing rooms, in vertical and horizontal footcandles (vfc and hfc).

## Videoconferencing Rooms

Videoconferencing lighting should be designed for the comfort of the occupants and for the quality of both sent and received images. Recent research as well as advances in camera technologies have changed some of the standard approaches to video-conference lighting – high light levels and high drama are no longer desirable. Balance and uniformity are the keys. The recently formed Committee on Videoconferencing and Presentations of the Illuminating Engineering Society of North America (IESNA) is in the process of developing both a Design Guide and IESNA Recommended Practice. Publication of the Design Guide is expected in 2005/6.

The primary function in a videoconference space is the achievement of effective conferencing or instruction, not televising, so the lighting should facilitate the latter without sacrificing the former. Cameras today can transmit clear images with much less light than in the past. However, the light needed for videoconferencing is still slightly more intense and more vertical than the lighting found in typical meeting rooms. The designer should strive to meet most of the needs for videoconferencing within a design for general conferencing, with a minimum of additional (and separately controlled) luminaires dedicated only to videoconferencing.

The subjects of the video camera require three kinds of light, strategies that have long been used in the theatre. However, unlike the theatre, this lighting should be accomplished without excessive contrast.

- **Fill light** – ambient light that increases light levels without harsh shadows.
- **Background Light** – a wall wash or light behind the subjects that set them apart from their background.
- **Key light** – Direct light from angles that enhance three-dimensional facial modeling. The optimal location is 45 degrees from the side and 45 from the horizontal, (although this is not always possible).

In rooms with limited space or limited budget, a well-designed indirect lighting system supplemented with directional key lighting can achieve these goals to an acceptable level. In spaces with rear-projection, however, indirect light can obscure the screen and must be separately controlled.

Relatively uniform lighting improves the transmitted image. The closer the range of luminance values are for every surface within the camera's view, the better the camera can transmit a clear image. The typical maximum contrast ratio that a consumer-grade color camera can handle is 1:30. Luminaires that maximize contrast and drama will overload the camera's contrast range – making it send an image that is pixelated. The camera 'guesses' the parts of the image that is outside the contrast range by stealing color from adjacent pixels, resulting in an unnatural appearance and chunky areas of color. Lighting designs that maximize inter-reflections within the room will create a smoother color field and clear, accurate camera images.

Most often, while the subjects are being filmed, they are also viewing one or more TV screens – one with their own image and one showing other participants located at a remote facility. Consequently, the monitors must be shielded from direct light, and glare must be controlled so the subjects are not visually disabled when viewing the monitors.

The design of the space should include the following considerations:

- **Reflectances:** In the case of video-conferencing, the primary surface reflectance is that of human faces.

Since humans come in a wide range of skin colors, the illuminance should be sufficient to adequately illuminate the detailed facial expressions of a dark skinned person without washing out detail on a light skinned person. Even wider is the range of clothing, with the maximum contrast being a white shirt and a black suit, far greater than the maximum camera range of 1:30. Since these reflectances cannot easily be altered, the lighting and the background room reflectances should be in the mid-range (30%-50%) so as not to create excessive contrast between the range of subjects in a room and their surrounds. The table is often

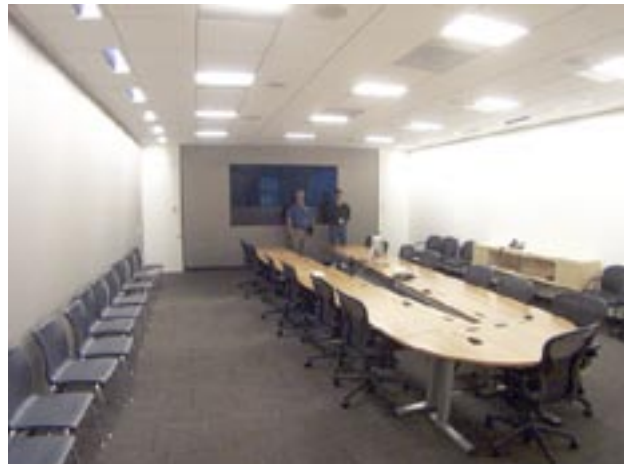

courtesy: Jim Benya, Benya Lighting Design/IESNA LVP Committee

well within the view of the camera, so should also be about 50% reflective, to allow a little diffuse light to bounce off. The table should be absolutely matte in texture. Confirm that the ceiling is out of range

Be sure that ceiling luminaires are outside of the camera's view in video-conferencing rooms.

of the cameras, as this should have a higher reflectance of 80-90% for indirect lighting. Walls out of camera range should be 70% or higher to promote interreflections.

- **Luminance Ratios:** The luminance ratios should be 3:1 preferred between the foreground and the background, and 2:1 preferred (5:1 max) between the vertical and horizontal surfaces. In addition, there should be more than a 10:1 ratio between the darkest and lightest surfaces that are in view of the camera (and in the control of the designer). Total uniformity (1:1) is not ideal, because it can flatten the appearance of faces and objects. Some contrast (2:1 or higher) is preferred to no contrast. It should be noted that these ratios are ideal goals, but are very difficult to achieve.

## ENERGY-EFFICIENCY STRATEGIES

### OFFICES-SPECIFIC STRATEGIES

- **Harvest daylight:** Utilize natural light to meet ambient office lighting needs wherever possible. Consider interior or exterior lightshelves to increase the penetration of indirect daylight deeper into the space. Control the electric lighting, heat gain and glare so that overall energy consumption is reduced without adversely affecting quality and comfort. See Technologies Section for continuous dimming controls and photosensor location. A full discussion of this topic is outside the scope of this manual, but is handled in many other excellent publications (see References).
- **Use task – ambient lighting** Whenever possible, provide task lights to supplement daylight and electric illumination in excess of 30 fc. In the case of meeting rooms or video-conferencing, provide separate dimming or switching controls for illumination above 30 fc.
- **Specify light-colored finishes** for room surfaces, partial height partitions and furniture, to reduce light absorption and improve comfort and system efficiency
- **Concentrate luminaires over workstations**, leaving spill light to illuminate adjacent circulation space.
- **Cluster activities** together that share similar lighting needs or similar time schedules.
- **Connect fixtures** together in logical control zones, so that luminaires for workers with similar tasks, or on similar time schedules, or adjacent to similar daylight conditions, can be controlled together, separate from spaces with different uses and conditions.
- **Zone the corridors** and open-plan areas with early-arrivers or after-hours workers in mind.
- **Use occupancy sensors:** Take advantage of intermittent use of workstations, offices and conference areas by ensuring that lights will be automatically turned off when the spaces are unoccupied. See Technologies Section for details of occupancy sensor applications.
- **Avoid unnecessary operation** of the lights by developing an energy-efficient strategy for night lighting and security lighting. See page 17.
- **Improve the task:** Evaluate the current visual tasks in the office and make improvements that will reduce reflected glare (such as improved monitor screens, or replacement of glossy papers with matte) or improvements in task contrast (such as lighter backgrounds and darker print, or larger print size, or the replacement of colored paper with white paper with colored borders). Improving the visibility of the task reduces the need for illumination and improves the quality of the lighting.



courtesy: Lighting Research Center, RPI, Delta Publications

Interior lightshelves increase the ambient daylight into the office, and block the sun.



The increased stringency of energy codes may not allow the prevalent use of common but less energy-efficient lighting strategies such as totally indirect lighting, semi-indirect pendants and coffers, and some 2x2 luminaires.

## ENERGY CODES: WATTS / SQUARE FOOT BUDGETS

FUNCTION	NYS ENERGY CODE		ANSI/ASHRAE/IESNA STD.90.1		NOTES
	2002	+/- 2007	1999/2001	2004	
OFFICE BUILDING (Building Type Method only)	1.3	1.0	1.3	1.0	1
Office-Enclosed	1.5	1.1	1.5	1.1	2,3,4
Office-Open Plan	1.5	1.1	1.3	1.1	2,3,4
Conference Meeting/Multipurpose	1.5	1.3	1.5	1.3	2
Classroom/Lecture/Training	1.3	1.4	1.6	1.4	2
Video-Conferencing					5

1. Multiply this value by the total square footage of the building, to determine the total building interior power allowance, using the Building Type method. 2. Multiply this value by the square footage of the dedicated space function. Sum the results of all the individual spaces in the building to determine the total building interior power allowance using the space-by-space method. The design of an individual space is not required to meet the watt/sf limits, as long as the total building connected load does not exceed the total interior power allowance. 3. NYS Energy Code does not distinguish between open plan and enclosed office types for power density. 4. NYS Energy Code states “Where lighting equipment is specified to be installed to meet requirements of visual display terminals as the primary viewing task, the smaller of the actual wattage of the lighting equipment or 0.35 w/ft<sup>2</sup> times the area of the space that the lighting equipment is in shall be added to the interior lighting power determined in accordance with this line item. 5. Neither code specifically addresses videoconferencing spaces. Use Conference/Meeting or Classroom/Lecture categories as most appropriate. Luminaires used exclusively for televising may be exempt from some codes.

## LIGHTING CONTROLS

The proper design and commissioning of lighting controls is essential for their successful operation, and to achieve the intended energy savings. The following recommendations relate to offices. More detail can be found in the Technologies Sections and References, as well as the night-lighting and zoning discussion in the Design Strategies section. Note that a luminaire can be controlled by several methods, such as daylight dimming, occupancy sensors and time clocks.

**Daylighting controls:** Daylighting only saves energy if electrical energy can be reduced, hence the term “daylight harvesting.” For office applications, provide continuous dimming ballasts in luminaires within the daylighted zone. Control rows of luminaires separately, as the orientation changes, or the distance from the window wall increases. Locate photosensors for either “closed-loop” or “open-loop” sensing strategies. See the Technologies and References Section herein for detailed daylighting control instructions.

**Open-plan offices:** In addition to any daylighting controls, “automatic shut-off” controls are required by the energy codes. (See Appendix A). In spaces with moderate density of personnel, and intermittent occupancy, ceiling mounted ultrasonic occupancy sensors are a good choice, coupled with local switches to turn the lights on. This is also a good strategy with flexible schedules and employees who work late or on weekends. The control zones should be sufficiently small (150-200sf) to truly save energy when a large open plan office is only partially occupied. In facilities that are occupied on a more rigid schedule, where almost all employees arrive and leave within an hour of each other, and there is more or less constant occupancy, a scheduling control system may be more cost effective. There should be an override capability, or a nightlight setting, so that a worker may occasionally work late or get to an interior zone without operating all the building lighting.

**Private Offices:** Manual-on, automatic-off occupancy sensors are the best choice of lighting control for most private offices. They save the most energy, give more control to the occupant, save lamp life and still meet the energy code requirement for automatic shutoff and bi-level switching. Unlike automatic-on sensors, they don’t automatically turn on when daylight is sufficient, and they don’t accidentally turn on when there is activity in the adjacent corridor. Even in an interior office, there is generally enough spill light from

the corridor to enter the office and pick up a briefcase, answer a phone, or drop off a file without turning the lights on. Sensors must be set internally, so that the automatic-off aspect cannot be overridden. See Technologies herein and Specifications on the DDC website.

**Task Lighting:** In addition to local on/off switches operated by the worker, task lighting can also be controlled with local infra-red occupancy sensors inside each cubicle. Additional personal control can be obtained by specifying task lights with fluorescent or compact fluorescent dimming ballasts at an increased cost. In the case of undercabinet lighting, this will not permanently reduce the connected load or reduce veiling reflections.

**Meeting Rooms:** Different projects will have different functional needs for their meeting rooms, but almost every one will benefit from two to three distinctive lighting conditions or light levels. All conference rooms should have an occupancy sensor for automatic shutoff. In addition, options for activating the lights range from simple manual-on switches or wall box dimmers, to daylight harvesting, to multiple scene pre-set systems.

**Videoconferencing Rooms:** Any luminaires dedicated to videoconferencing functions should be controlled separately, and be clearly labeled or controlled by authorized staff. In addition, the direct and indirect components of luminaires should be controlled separately. Depending on the degree of complexity and the experience level of the room users, controls can range from simple manual switches and dimmers, to multiple scene pre-set systems. Like all other meeting room lighting, videoconferencing luminaires must turn off automatically when the room is not occupied.

## OTHER CONSIDERATIONS

**Emergency Lighting:** Special care should be taken to ensure all exits and paths of egress are clearly visible above partial height partitions

**Electrical Code Issues:** Undercabinet lighting should be 120 volt and fitted with a local switch.

For reduced energy consumption, the following four-foot long fluorescent lamps are the DDC standard: 32 Watt T8, 3,100 lumen, CRI 85+, 3500 Kelvin, low mercury, extended life (24,000 – 30,000 hours). Note that DCAS (NYC Department of Citywide Services) will have available one of the following lamps: GE #F32T8 XL SPX35 HLEC (10326); Philips #F32T8/ADV/835/ALTO (13988-1); Osram/Sylvania #FO32/835/XPS/ECO (21697).



## SAMPLE LUMINAIRE SCHEDULE FOR OFFICES

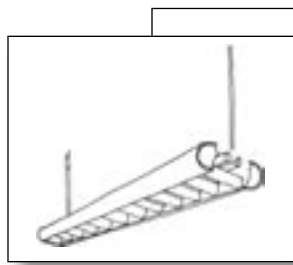

### PENDANT FLUORESCENT DIRECT/INDIRECT TWO-LAMP

**Location:** Offices  
**Lamps:** (2) 28-32W, High Performance T8, 835 – 841 color  
**Description:** Stem-mounted fluorescent luminaire in lengths of 8'. White baked enamel finish. Minimum 30% uplight. Minimum 40% downlight. Minimum fixture efficiency 80%. Cross baffles 1-3/4" deep x 2" on center, semi-specular low-iridescent or white painted. Total 4-lamps per 8' long fixture. Multiple-lamp electronic parallel instant-start ballast. Also available in 12' lengths or continuous rows. Mount a minimum of 7' above finished floor. Minimum 12" stem, 18" or more preferred. Stem length varies with ceiling height.

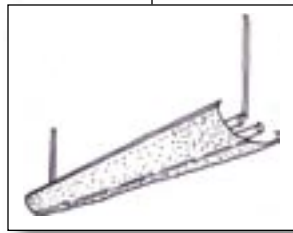

### PENDANT FLUORESCENT SEMI-INDIRECT

**Location:** Offices  
**Lamps:** (2) 28-32W, High Performance T8, 835 – 841 color  
**Description:** Stem-mounted fluorescent luminaire in lengths of 8'. White baked enamel finish. Minimum 10% downlight. Total 4-lamps per 8' long fixture. Multiple-lamp electronic parallel instant-start ballast. Minimum 80% fixture efficiency. Mount a minimum of 7' above finished floor. Minimum 12" stem, 18" or more preferred, unless specifically designed for low ceilings. Stem length varies with ceiling height.

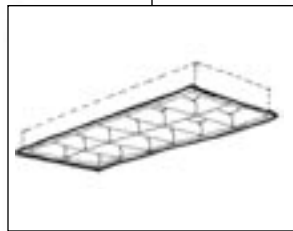

### RECESSED 2'x4' TWO-LAMP PARABOLIC TROFFER

**Location:** Offices, private and public  
**Lamps:** (2) 28-32W, High Performance T8, 835 – 841 color  
**Description:** Recessed fluorescent troffer 2' by 4' with white baked enamel interior, semi-specular low-iridescent parabolic louvers with 12 cells. Minimum 2-3/4" deep louvers. Use white painted louvers in private offices. Two-lamp electronic instant-start ballast, nominal 55 input watts. 73% minimum fixture efficiency.

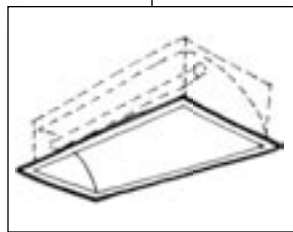

### VIDEOCONFERENCE WALL WASH

**Location:** Video-Conference and meeting rooms, open plan offices  
**Lamps:** (1) 40W CFL, 830 – 835 color  
**Description:** Nominal 1'x2' recessed fluorescent wall wash located 2' to 4' away from wall being washed. Semi-specular or white painted reflector. Spaced 4' to 10' on center depending on distance from wall, ceiling height, and desired light levels. Electronic instant-start ballast.

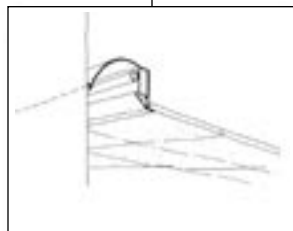

### FLUORESCENT CONTINUOUS WALL WASH

**Location:** Open plan office walls, video-conferencing and meeting room walls  
**Lamps:** (1) 28-32W, High Performance T8, 835 – 841 color  
**Description:** Recessed wallwasher with semi-specular aluminum reflector. Nominal 55 input watts per (2) lamps, 67% minimum efficiency.



### COMPACT FLUORESCENT TASK LIGHT

**Location:** Desktop  
**Lamps:** (1) 13W to 18W, CFL, 830- 835 color  
**Description:** Desktop compact fluorescent. Integral 120v ballast. Articulated arms allow adjustment in three planes. A maximum range of 24" above the desktop. Weighted base, grommet-mount or clamp-mounted to desktop.

## LIBRARY DESIGN BRIEF

The NYC Department of Design and Construction (DDC) manages the construction and renovation of NYC's municipal buildings, including libraries. These may be parts of larger offices, judicial or educational projects, may be specialized by topic (e.g., law or medicine) or user (e.g., children, visually impaired), or may be stand-alone buildings open to the public. Public libraries today not only house book collections, but they often serve as community centers, with auditoriums, classrooms, language labs, public book reading areas, displays and exhibits. To compete with retail bookstores, New York libraries often offer enticing displays of recent publications, magazines, videos, books on tape, and lively children's areas. The lighting guidelines below focus on a few key space types that are common to most libraries: book stacks, reading areas, and special collections with rare and delicate materials.

### LIGHTING QUALITY AND QUANTITY STRATEGIES

Libraries have specific considerations because of their function and spatial characteristics. Please review and use the guidelines below, in concert with the basic issues of lighting quality and design strategies set forth earlier in the Design Team Strategies section of this manual.

### LIBRARY-SPECIFIC LIGHTING QUALITY AND QUANTITY ISSUES

ISSUE	IMPORTANCE
Relationship between light source and visual task and viewer	Very Important
Reflected Glare	Very Important
Direct Glare	Very Important
Color Appearance and Color Contrast	Very Important
Light Distribution on Surfaces	Very Important
Degradation factors	Very Important
Appearance of Space and Luminaires	Important
Modeling of Faces or Objects	Important

From The IESNA Lighting Handbook, 9<sup>th</sup> Edition.

### Relationship Between Light Source And Visual Task And Viewer

Some visual tasks in a library are similar to those in offices – reading at a desk or table or using a computer. Others are more specialized, like finding a book on a shelf. This requires looking above and below eye level in narrow aisles, while attempting to identify a title, author or code number on narrow spines with a variety of typefaces, colors and potentially shiny materials. Bookstack viewing is subject to direct glare and veiling reflections, so the relationship of both the lighting source to the book spines and the viewer to the book spines is very important. On the other hand, veiling reflections (a form of glare that puts a reflective veil of light on a surface, obscuring the task behind), can be overcome by movement of the viewer to a better viewing angle, or by eliminating the use of shiny materials to label books. See “Improving the Task,” later in this Brief. Light levels for stacks are measured on the vertical face of the books (with standards set for 30” above the floor).



Luminaires are oriented parallel to the stacks in this school library.

courtesy: Gruzen Samton

## Glare Control –Reflected And Direct Glare

In libraries, microfilm and microfiche readers creates the most serious potential for reflected glare, followed by computers and electronic card cataloguing. Direct glare is a particular problem when looking for books above eye level in the stacks, but glare control should be considered for all library tasks such as computer usage, lectures or story telling, where the viewer is looking ahead rather than downward. Even lighting fixtures outside of the field of view can cause overhead glare, so shiny (specular) louvers and high-output lamps visible from any angle should be avoided in work areas. Use white painted or brushed metal (semi-specular) louvers and baffles.

## Color

As libraries have become more like retail bookstores in their character, color has become more prevalent, especially in children's areas, and at racks of newest releases, videos, displays and exhibits. In order to limit the number of lamp types on a project, select one color per lamp type to be used for most applications. Fluorescent lamps with high color rendering (CRI 85+) and color temperatures between 3500 and 4100 are appropriate for library functions. For example, The Brooklyn Public Library System currently prefers color temperatures of 3500. Compact fluorescent or low wattage metal halide lamps at 3000 Kelvin, or very limited use of halogen sources, may be acceptable for decorative lighting or displays.

## Luminances of Room Surfaces

Luminance ratios (representing the contrast between bright and dark surfaces) in reading rooms and work areas should be close to uniform, not exceeding 20:1 ratio between the brightest and darkest surface. However, within the stack areas, the tall, narrow configuration of the aisles will result in a considerably wider distribution of illuminances and luminances.

## Degradation Factors

Paper is very sensitive to ultra violet (UV) radiation, heat and light. Delicate and rare books should be restricted to areas where the light exposure is controllable, deliberate, and limited. Windows and electric light sources should be shielded or provided with UV filters. See "Rare Book Archives" below.

## Reflectances and Finishes

In order to achieve the desired luminance ratios and uniformity, reflectances should be high and finishes should be matte or eggshell. Ceilings should be a minimum of 80% reflectance - 90% if direct/indirect pendants are oriented perpendicular to the stacks and greater inter-reflections are required. Walls should be a minimum of 70% reflective, bookshelves and furniture should be at least 60% reflective, and floors not less than 20% reflective. Darker wood accents may be used at the ends of stacks, but the shelving itself should be a light colored as possible to increase inter-reflection in the narrow aisles. Polished, glossy and shiny surfaces should be avoided, because specular reflections can reduce visibility and be distracting for the viewer. The most matte finish available that will provide acceptable maintenance should be used. Use eggshell or semi-gloss paints.

## Appearance of Space and Luminaires

The luminaire layout and appearance of lighted surfaces affect how a library is perceived, and can be an important contribution to the orientation of the visitor. The architect and lighting designer should work together to create surfaces and room variations that reinforce a visual hierarchy. For example, dropped fascias with large graphics over circulation desks and information counters can be enhanced with light to visually organize the space. Different lighting approaches in circulation spaces, stack areas and reading areas further serve to orient the user. Care should be taken to avoid chaotic lighting patterns that will be disorienting. The style of light fixtures is particularly important in libraries in historic buildings.

## Three-dimensional Modeling

The natural appearance of faces and objects in a library contribute to the feeling of comfort and sense of well being for both visitors and staff. Light that is directed totally downward can cause unflattering and even confusing shadows, and is the least desirable approach. Lighting strategies that combine direct and indirect distributions generally achieve the most natural appearance for the space and occupants.

## LIGHT LEVELS (RECOMMENDED AVERAGE MAINTAINED ILLUMINANCE, IN FOOTCANDLES (FC))

TASK	HORIZONTAL FC AT 30" ABOVE FLOOR	VERTICAL FC AT 30" ABOVE FLOOR	NOTES
Reading Tasks	30-50		1
Bookstacks, Active Use - Lights parallel	30	20-30	2
Bookstacks, Active Use - Lights perpendicular	20	10-20	2
Bookstacks, Inactive	15	5	2
Book repair or binding	30-50	3	1
Cataloguing	30-50		1
Card files	30-50	5	1
Carrels, individual study desks	30-50		1
Circulation desk	30-50		1
Audiovisual areas	30-50		1
Audio listening areas	30		
Microform areas	30		

Values from [IESNA Lighting Handbook](#), Eighth and Ninth Editions, unless otherwise noted. 1. Higher values to be provided by local task lighting or in specially designated areas, in order to accommodate older eyes and visual impairments. 2 – Lower values recommended by authors to respond to energy restraints and need for flexibility.

## DESIGN AND LAYOUT STRATEGIES

### READING AREAS

Unlike offices, where workers have fixed desks and environments, libraries typically offer a selection of areas with different character, from group tables to lounge chairs to individual study carrels. This approach also offers lighting variations that can meet the needs of a wide range of users. Good quality lighting and adequate glare control should be provided in all reading areas, although a wider range of light levels throughout the library is acceptable when the user may choose where to sit. Most reading areas should be located close to windows, to provide more light and to give occupants a connection to the outdoors. Direct sun penetration should be controlled since it can be damaging to the books, even though a few readers might actually choose to sit in a sunlit location. Reading areas interspersed with the stacks typically provide higher light levels than average, and should be clearly labeled as a high-light level area with priority seating for the elderly and visually impaired. Glare control is especially important for those individuals. In historic reading rooms, or any library with high ceilings, the primary source of light for reading is often task lights mounted in study carrels or along the centerline of reading tables, supplemented by a low level of ambient light. Unfortunately, table lamps in this position create veiling reflections and reduce flexibility, so a greater ratio of ambient to task lighting is preferred when feasible.



Undershelf task light with local rocker switch in study carrels.

Finally, individual study carrels are often the choice of those requiring extra focus and protection from distractions. The side panels and carrel shelf can block some of the ambient lighting in a room, so supplemental task lighting should be included. Even without a shelf, an occupant-controlled task light can give the user a desirable degree of control and focus.

## STACK LIGHTING

Illuminance standards for bookstacks are based on the light reaching the vertical plane of the books, not the horizontal plane common to other tasks. The configuration created by tall stacks (typically 7'-0") and narrow aisles (typically 3' clear width) absorbs most of the light before it reaches the bottom shelves. There are two design approaches to lighting tall bookstacks: Running the luminaires continuously and parallel to the stacks (attached to the stacks or centered above the aisle), or orienting the luminaires perpendicular to the stacks. Both have their advantages and disadvantages:

### PARALLEL TO STACKS (DIRECT DOWNWARD DISTRIBUTION)

#### Advantages:

- Efficiency: Half the watts of perpendicular to achieve IESNA recommended light levels.
- Easier to control with occupancy sensors. Preferred for rare books or archives.

#### Disadvantages:

- Requires special luminaires with narrow "stacklight" distribution (see Sample Luminaire Schedule).
- Restricted to permanent stack locations. Change in stacks requires change in lights.
- Shiny reflector required to achieve narrow distribution can cause glare from some angles.
- Totally directional light can be harsh. 10% uplight helps a little.
- More linear footage of luminaires required.

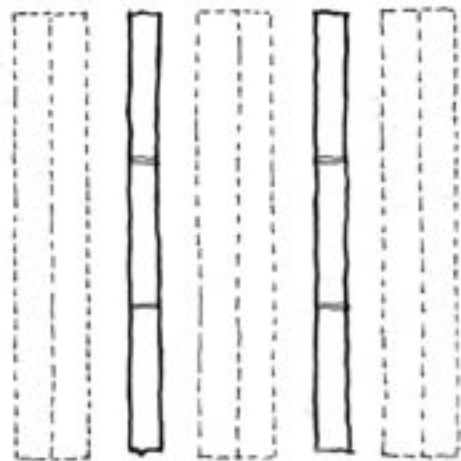

Luminaires are oriented parallel to stacks.

### PERPENDICULAR TO STACKS

#### Advantages:

- Flexible stack layouts. Allows addition and relocation of stacks.
- More comfortable. Indirect lighting contributes a higher proportion of light to stacks than with direct stacklights.
- Use same direct/indirect luminaire in adjacent or interspersed reading areas.

#### Disadvantages:

- Less efficient: Uses twice the energy to achieve IESNA recommendations.
- Less uniformity on face of stack between luminaires.
- Harder to control, but two level switching and zoning is still possible

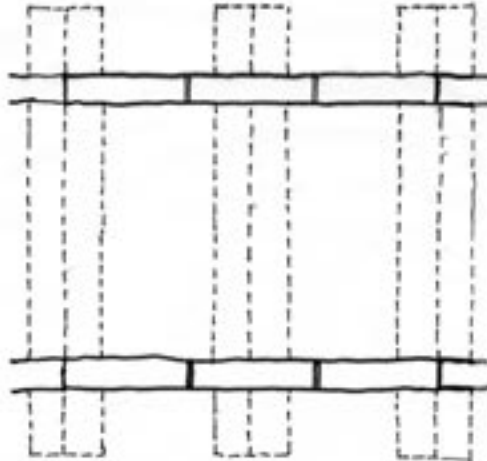

Luminaires are oriented perpendicular to stacks.

## FLEXIBILITY VERSUS ENERGY SAVINGS

Whenever feasible, specialized stacklight luminaires oriented parallel to the stacks should be used for better utilization of energy. These fixtures must be mounted about 6" above the top of the stack to achieve the IESNA recommended illuminance with a single-lamp fixture run continuously. About 10% uplight will help reduce the apparent brightness of the light fixture and provide reflected light that helps reduce shadows.

Although many librarians prefer perpendicular layouts to maximize future flexibility for stack layouts, it is very difficult to meet the newest energy codes with this configuration and still meet the IESNA recommendations for light levels. The real benefits of flexibility should be carefully addressed: in many cases flexibility is designed in but never used. Since the perpendicular orientation of direct/indirect luminaires provides better visual comfort (due to increased indirect light), a lower vertical light level should be allowed on the face of the books at 30" above finished floor. The light levels given in the chart above reflect this trade-off.

## RARE BOOK OR ARCHIVAL STORAGE

Paper is extremely sensitive to degeneration, not only from visible light, but also from ultra violet radiation, heat, and humidity. Controlling the intensity, spectrum and duration of light mitigates the first three culprits. Energy efficient sources by definition emit a greater portion of light than heat, so fluorescent remains the lamp of choice compared to incandescent or halogen. Ultra violet radiation is emitted by natural light and all conventional lamps, particularly fluorescent and metal halide, but can be controlled at the source by UV filters in clear acetate sleeves, or by UV filtering lenses. Window glass and low-e filters absorbs some, but not all of UV wavelengths. About 80% of UV is absorbed during reflection off of white paint containing titanium dioxide, as well.

Since these areas are restricted to staff rather than the general public, light levels can be reduced in both the stacks and the staff work areas and some levels raised only when the staff needs the extra light. In rooms that entirely house stacks for book storage and retrieval by staff only, such as rare and precious book collections, one-lamp luminaires that distribute light directly downward are a good choice. Locate the fixtures parallel to the aisles to light the vertical surfaces of the stacks. In this application, each row or partial row of lights can be separately controlled, using switches or occupancy sensors to protect rare/precious books and save energy. Only that specific row of luminaires located above the retrieved book are turned on. A staff dedicated to the preservation of materials is often motivated enough that manual controls can be effective in rare book archives. However, some form of automatic-off is required in all library spaces.

Old books and historic papers are often faded and hard to read, requiring higher levels of light for close examination or repair. This examination-level of light should be provided only by supplemental task lights. The use of task lights combined with magnifiers can make the task easier and reduce the need for lighting. Again, fluorescent and compact fluorescent sources with UV filters are the best choice, due to the potential for thermal degradation caused by the heat of incandescent and halogen sources. Even incandescent and halogen lamps contain a measure of ultra violet light, so all sources should have UV shields. *The Museum Environment* (see References) is an excellent reference source for protection of sensitive materials.

## ENERGY EFFICIENCY STRATEGIES

**Daylighting:** Daylighting can be a wonderful lighting strategy for reading rooms and staff areas of libraries, and has historically been an organizing principle for some of the world's great libraries, (some of which were designed before safe, inexpensive, electric light was available) such as Labroust's bibliothèques in Paris, or the many Beaux Arts libraries in New York and Boston. Nonetheless daylighting should be limited to reading rooms and staff areas to avoid material degradation from natural light. Daylight harvesting is an excellent strategy for library reading rooms: it provides more and better light; plus the hours of daylight coincide with the primary operating hours of libraries. Consider using local task lights to supplement the daylight. Separately control the luminaires near windows. Since short-term exposure to sunlight or long-term exposure to daylight can harm books and paper based materials, orient shelving so that the ends of stacks face toward any windows. Avoid or carefully control natural lighting in any rare book or archival rooms.



Boston Public Library

**Energy efficient sources:** High performance fluorescent lighting is a good choice for libraries. It is diffuse, linear, easily controlled, and restrikes instantly for emergency usage. Semi-indirect metal halide solutions have been successful in some libraries, although the metal halide sources create a phosphorescent effect with some types of paper. A separate solution for emergency lighting must also be designed, since the metal halide lamps will not instantly re-strike when power has been interrupted. Consider metal halide PAR lamps for exhibit or display in spaces with high ceilings.

**Narrow distribution luminaires:** The first stack-lighting fixture shown in the luminaire schedule (on the last page of this Brief) has a narrow distribution that directs the light to the lower portion of the shelves, and is an excellent choice for parallel stack lighting. A diagram of its “photometric curve” is shown on the right.

There is another style of luminaire with a bare lamp and radial baffles, shown below, which is also called a stacklight by many manufacturers and has been widely used in the past. However, without a reflector, this luminaire has a much wider photometric curve, with less of its light distributed directly downward. This is more effective in schemes running perpendicular to the stacks, but the exposed lamp may cause glare. Both fixture types have the same luminaire “Efficiency” rating (about 60%), but the designer must select the appropriate photometric distribution for the specific application as well.

**Improving the task:** The reference numbers on the spines of books represent the visual task that, if improved, will achieve the greatest lighting improvement. The largest point size, boldface lettering, and an easy to read typeface will make the task more visible, requiring less light. In addition, matte-finished adhesive tapes should be used to protect the numbers, rather than shiny tapes or acetate, to reduce veiling reflections.



Photometric curve

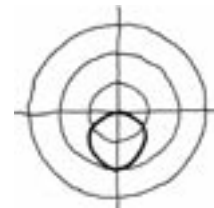

Photometric curve

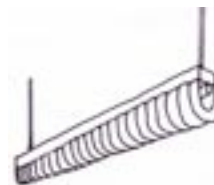

Radial baffled luminaire

## ENERGY CODES: WATTS / SQUARE FOOT BUDGETS

FUNCTION	NYS ENERGY CODE		ANSI/ASHRAE/IESNA STD.90.1		NOTES
	2002	+/-2007	1999/2001	2004	
Library – Whole Building (Building Type Method Only)	1.8	1.3	1.5	1.3	1,2
Library – Tenant Space	1.8	1.7			2,3,4
Card File and Cataloging Areas			1.4	1.1	2,4
Stack Areas			1.9	1.7	2,4
Reading Areas			1.8	1.2	2,4

1. Multiply this value by the total square footage of the building, to determine the total building interior power allowance, using the Building Type method. 2. Multiply this value by the square footage of the dedicated space function. Sum the results of all the individual spaces in the building to determine the total building interior power allowance using the space-by-space method. The design of an individual space is not required to meet the watt/sf limits, as long as the total building connected load does not exceed the total interior power allowance. 3. NYS Energy Code states, “Where lighting equipment is specified to be installed for decorative appearances in addition to lighting equipment specified for general lighting and is switched or dimmed on circuits different from the circuits for general lighting, the smaller of the actual wattage of the decorative lighting equipment or 1.0 w/ft<sup>2</sup> times the area of the space that the decorative lighting equipment is in shall be added to the interior lighting power determined in accordance with this line item. 4. NYS Energy Codes do not list power densities for the individual types of spaces within the library.

## LIGHTING CONTROLS

**Reading Areas:** Control lighting near windows separately. If daylight can be effectively utilized, specify continuous daylight dimming controls and dimming ballasts in all luminaires located in the daylight zone. In areas that are infrequently occupied, consider placing 50% to 75% of the lights on occupancy sensors, so that only moderate levels of light are operating while the reading area is unoccupied. All lights should be turned off by an automatic timeclock with an override for staff. After hours night lighting should be no more than the minimum necessary for emergency personnel.

**Task Lighting Controls:** The reading table lamps and carrel lights should be integrated into the furniture with a local switch or dimmer for users to turn on the fixture, plus ancillary wiring to turn off all of the table lamps or carrels at the end of the day. In addition to local switches, many lighting manufacturers are able to provide electrical receptacles and computer jacks at the base of luminaires, specifically for applications such as libraries and schools.

**Luminaires Perpendicular to Public Stacks:** If flexible layout and bookstack flexibility is a primary issue, then it is likely that the typical stack lighting layout will be extended to adjacent areas not currently occupied by stacks. The lighting designed for stacks will often produce two to three times the light levels required for an unobstructed reading area. For this reason, the potential stack area should be realistically sized, and the luminaire wiring should be broken down into a pattern of control zones, so that individual areas can be flexibly controlled. These control zones will be much smaller than a typical electrical circuit. Another strategy is to provide multiple-lamp luminaires with in-line wiring to allow multiple-level switching while maintaining a uniform distribution. This way, lamps can actually be removed in luminaires over areas not currently used for stacks, until such time as the space function changes.

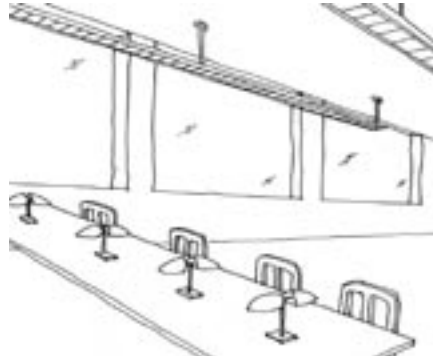

Control lights near windows to respond to daylight. Consider individual local switches for reading lights on table.

**Luminaires Parallel to Public Stacks:** It is easier to control lighting oriented parallel to the bookstacks, because every luminaire is associated with an aisle. There are several common control strategies for this orientation. For isolated stack areas infrequently used, the adjacent pedestrian pathways can be lighted, but the stack aisles left unlighted until an individual enters that row. Infra-red occupancy sensors work well for this function. The sensors should detect motion when a person is two to three feet into the stack aisle, but should not respond to movement outside of the stack. There is generally enough spill light from the main pathways so that this design is neither a safety or security hazard. The occupancy sensors should have at least a 15 minute time delay before turning the lights off, to increase lamp life. Since the lights running parallel to the stacks are typically one-lamp fixtures, a uniform “low-high” alternative to this approach would require a two- or three-stepped ballast. A constant low level of light is present in the stacks, until the stack is entered. This approach is preferred when the stacks are visible from reading areas, and the contrast from totally off to full on would be visually distracting. When stack use is heavy throughout the operating hours of the library, these strategies are probably not cost effective, and the aisle lighting should remain on.

**Rare Book Archives:** Two factors affect the lighting controls in archival spaces: protecting the books from light is a top priority; in addition, these areas are typically under the control of experienced librarians, rather than the general public. Luminaires oriented parallel to the stacks, with a tightly focused stack lighting distribution, help create more uniform light levels from the top to bottom shelves, but, the lights should be kept off as much as possible. Even the ambient lighting in the pedestrian paths at the end of the aisles should not have a wide distribution, should provide minimal light levels, and should be off whenever the room is unoccupied. The individual seeking a book should be able to find the correct aisle, and then go down that aisle to the desired book, while activating the fewest number of lamps. Infra-red occupancy sensors located at the ends of each row are appropriate for short rows, and intermediate sensors can be located for longer rows. Another strategy is to provide timer switches at the end of each aisle. The librarian would push the switch upon entering the aisle and could turn it off upon leaving. If not turned off, the lights would be extinguished automatically after a set time. The time delay setting of the timer switches or occupancy sensors should be based on the fragility of the book collection. Programmed start ballast should be considered for luminaires where it is likely that they will be turned on and off significantly more than five times a day.



## OTHER CONSIDERATIONS





**Commissioning:** The specialized nature of the lighting controls for a library mandate their careful calibration and commissioning. This is the opportunity to tailor the lighting for the current configuration, even though it has been designed for a range of future layouts. This not only improves the lighting quality, but saves considerable energy and cost of operation. Controls should be re-commissioned every three years, or whenever there is a significant relocation of stacks or furniture.

**Emergency Lighting:** Special care should be taken to ensure all exits and paths of egress are clearly visible, especially for people situated in stack areas, during a power outage or emergency.

**Electromagnetic Interference:** Book theft detection systems manufactured prior to 1992 are susceptible to high frequency interference from electronic ballasts. Such systems emit a low intensity, high frequency magnetic field that interacts with the “tattle-tape” attached to the book jacket and sounds an alarm. Electronic ballasts located within 20’ of these older systems (including the floor above and below) could overload the system and cause it to shut down. Since 1992, detection equipment manufacturers have been producing digital equipment with frequency filters that eliminate the interaction.

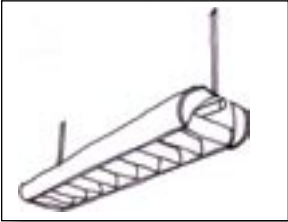
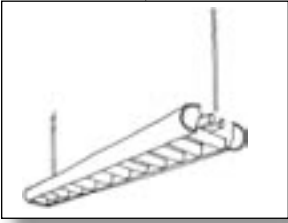
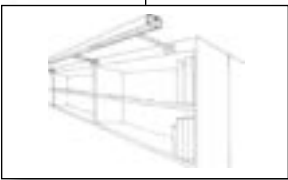
For reduced energy consumption, the following four-foot long fluorescent lamps are the DDC standard: 32 Watt T8, 3,100 lumen, CRI 85+, 3500 Kelvin, low mercury, extended life (24,000 – 30,000 hours). Note that DCAS (NYC Department of Citywide Services) will have available one of the following lamps: GE #F32T8 XL SPX35 HLEC (10326); Philips #F32T8/ADV/835/ALTO (13988-1); Osram/Sylvania #FO32/835/XPS/ECO (21697).

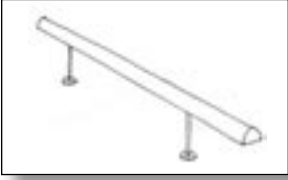
## SAMPLE LUMINAIRE SCHEDULE FOR LIBRARIES

	<p><b>ONE-LAMP "STACK" DISTRIBUTION FLUORESCENT LUMINAIRE - SURFACE OR PENDANT</b></p> <p><b>Location:</b> Stacks (parallel), Rare book archives.  <b>Lamps:</b> (1) 28-32W, High Performance T8, 835 – 841 color  <b>Description:</b> Stem-mounted fluorescent luminaire in lengths of 8' or 12'. Minimum 90% downlight. Minimum fixture efficiency 62%. Cross baffles 1-3/4" deep x 2" on center. Semi-specular low-iridescent or white painted cross baffles. Total 2-lamps per 8' long fixture. Two-lamp electronic instant-start ballast, nominal 55 input watts. Also available in 12' lengths and continuous rows. Mount a maximum of 1'-6" above top of stacks, 6" preferred. Provide ultraviolet filter sleeves for rare book collection.</p>
	<p><b>TWO-LAMP PENDANT FLUORESCENT DIRECT/INDIRECT</b></p> <p><b>Location:</b> Offices, Reading Areas, Stacks (perpendicular)  <b>Lamps:</b> (2) 28-32W, High Performance T8, 835 – 841 color  <b>Description:</b> Stem-mounted fluorescent luminaire in lengths of 8'-0" or 12'-0". White baked enamel finish. Minimum 30% uplight. Minimum 40% downlight. Cross baffles 1-3/4" deep x 2" on center. Semi-specular low iridescent or white painted cross baffles. Total 4-lamps per 8' long fixture. Four-lamp electronic instant-start ballast, nominal 110 input watts. Minimum fixture efficiency 80%. Also available in 12' lengths and continuous rows. Mount a minimum of 6'-8" above finished floor. Minimum 12" stem, 18" preferred.</p>
	<p><b>STACK-MOUNTED STACKLIGHT</b></p> <p><b>Location:</b> Stacks (may supplement ambient lights, or provide all stack lighting)  <b>Lamps:</b> (1) 28-32W, High Performance T8, 835 – 841 color  <b>Description:</b> Surface-mounted cantilevered fluorescent with narrow distribution. Total 2-lamps per 8' long fixture. Two-lamp electronic instant-start ballast, nominal 55 input watts. Mount a minimum of 12" from shelf edge, 18" preferred.</p>
	<p><b>FLUORESCENT VALANCE LIGHT</b></p> <p><b>Location:</b> Graphics, signage, display racks  <b>Lamps:</b> (1) 28-32W, High Performance T8, 835 - 841 color  <b>Description:</b> Standard fluorescent industrial strip with single lamp, mounted on side to back of valance. Nominal 8" housing with two lamps in line. Two-lamp electronic instant start ballasts, 55 nominal input watts. Use compact-fluorescent continuous socket-strips for curved valances.</p>
	<p><b>LINEAR TABLE LAMPS WITH OPTIONAL PLUG-IN COMPUTER HOOKUPS</b></p> <p><b>Location:</b> Reading Room tables  <b>Lamps:</b> (1) 25W or 28-32W, High Performance T8, 835 - 841 color  <b>Description:</b> Tabletop linear fluorescent, pedestal mounted to top of reading table. Integral multi-lamp 120v ballasts. Bolt-through- mounting. Maximum stem length 24" above the table top.</p>
	<p><b>INDIVIDUAL TABLE LAMPS WITH PLUG-IN COMPUTER HOOKUPS</b></p> <p><b>Location:</b> Reading Room tables  <b>Lamps:</b> (1) CFL, 26 watt quad, 4-pin, 830 – 835 color  <b>Description:</b> Tabletop compact fluorescent. Integral 120v ballast. Computer ports and convenience 120v outlets. Maximum stem length 24" above the table top.</p>
	<p><b>STUDY CARREL AND UNDER-SHELF TASK LIGHTS</b></p> <p><b>Location:</b> Reading areas, Staff work areas,  <b>Lamps:</b> (1) 17W, 25W or 28-32W, High Performance T8, 835 – 841 color  <b>Description:</b> Surface-mounted fluorescent with solid front. Nominal 2', 3' or 4' in length. Lateral prism task lens. One-lamp instant-start electronic ballast. Integral rocker switch. Mount under shelf.</p>

# ADULT DETENTION FACILITIES DESIGN BRIEF

The NYC Department of Design and Construction (DDC) manages the construction and renovation of NYC's correctional facilities. These guidelines specifically apply to the secure areas of Adult Detention facilities like Rikers Island and New York City jails, and will generally apply to juvenile detention centers and courthouse prisoner holding facilities. In addition, some guidelines may apply to other space types where security and vandalism are primary concerns, like psychiatric wards, homeless shelters, drug rehabilitation and halfway houses.

## LIGHTING QUALITY STRATEGIES

Correctional facilities have specific considerations because of their function and spatial characteristics. Please review and use the guidelines below, in concert with the basic issues of lighting quality and design strategies set forth earlier in the Design Team Strategies section of this manual.

## SPECIFIC LIGHTING QUALITY ISSUES PRIORITIES

ISSUE	IMPORTANCE
System Control	Very Important
Modeling of Faces or Objects	Important
Light Distribution, uniformity, reflectances	Important
Flicker	Important
Daylight Integration and Control	Important
Color Appearance (Dayroom)	Important
Direct Glare (Dayroom)	Important
Relationship of viewer to source and task (Surveillance)	Important

From The IESNA Lighting Handbook 9<sup>th</sup> Edition.



courtesy: STV Architects

Dayrooms and visitation rooms provide excellent opportunities to introduce daylighting.

### System Control

This issue is cited as “very important” by the IESNA because of the needs of the Corrections Officers for immediate and total control of the lighting in emergency situations. While in some facilities some inmates are allowed a measure of personal control of their lights, the Corrections Officers always retain the ability to override personal control. Lighting controls are discussed in greater depth in the specific space-type recommendations below.

### Modeling of Faces and Objects

The lighting should enhance the ability of the cameras and staff to identify faces and clearly discern evidence of violence, contraband or weaponry held in prisoners' hands or under clothes. Light coming from multiple directions, with a slight bias from one direction, will give just enough three-dimensional definition, without creating strong shadows.

### Light Distribution, Uniformity and Surface Reflectances

To aid both visual and electronic surveillance, strong shadows should be avoided in all high security areas. Luminance ratios should be close to uniform, preferably no more than a 5 to 1 ratio between maximum and minimum luminances of room surfaces. In order to achieve the desired uniformity, reflectances should be high and finishes diffuse. Ceilings should be a minimum of 80% reflectance. Walls should be a minimum of 70% reflective generally, with 60% acceptable below 30” in common spaces (i.e., not cells). Polished, glossy, and shiny surfaces should be avoided, because specular reflections can reduce visibility. The most matte finish available that will provide acceptable maintenance should be used. Use eggshell paints, tiles, or anti-graffiti coatings. Use heavily brushed metal surfaces. Avoid glossy floor finishes and polishes.

## Flicker

Response to lamp flicker can range from annoyance to extreme agitation, and can reduce self-control. For this reason, flicker should be eliminated in a high-stress environment. Use high-frequency electronic ballasts to prevent fluorescent or metal halide sources from flickering. Defective or failing ballasts that create lamp flicker should be replaced immediately.

## Daylight Integration and Control

Daylight and a visual connection to the out-of-doors can have a calming effect on detainees and the staff. It maintains a connection to the outside world and eases the transition from incarceration to freedom. Every effort should be made to introduce properly designed fenestration into secure areas. Control window glare and sun patterns, so that visual and electronic surveillance is not compromised.

## Color

Use better color rendering lamps, with a CRI of 84 or higher. Use a correlated color temperature of 3500 to 5000 Kelvin. Good color rendering will aid in visibility and surveillance, and improve the morale of inmates, Corrections Officers and visitors. Since the occupants are not incarcerated in NYC facilities for more than a year and they have access to the out-of-doors, there are no health benefits to lamps emitting UVA or UVB radiation. The use of so-called “full-spectrum lamps” is neither necessary nor recommended.

## Direct Glare

Due to the physical constraints involved in manufacturing luminaires that meet vandal-proof criteria (below), high-security luminaires do not have louvers or visors for the control of luminaire glare. Glare control should be accomplished by the proper placement of luminaires. In particular, glare control should be employed to keep lighting off of observation windows and out of the view of cameras and guards in fixed locations. Indirect lighting using coves or pendant luminaires is only feasible in rooms with sufficient ceiling height to make inmate access impossible.

## Biological Effects

Lighting levels should be reduced in the evenings and nighttime to enable the inmates to have a normal sleep cycle. Preliminary research has shown that red light (660 nm) has the least affect on human circadian (daily) rhythms. Although the research is not conclusive, the design teams may consider red lights for night lighting in cells and dormitories as long as surveillance is not compromised. On the other hand there should be a way for night-shift Corrections Officers to receive intervals of high levels of light to improve alertness. This photo-biological “boost” should occur in locations remote from sleeping inmates (like a break room) and is best received sometime between 12:00am and 3:30am. Studies suggest that one or more sessions under bright blue light (420-480 nm) with an intensity about four times higher than the ambient level (e.g. 100-150 fc), for a duration of 15 minutes each will promote mental alertness. Additional 5000K+ and 85 CRI lamps can be provided on a separate timer switch for this nighttime function.

## LIGHT LEVELS

### RECOMMENDED AVERAGE MAINTAINED ILLUMINANCE, IN FOOTCANDLES (FC):

FUNCTION	HORIZONTAL FC	VERTICAL FC	NOTES
Cells & Dormitory	20 general – 30 reading	5	3
Cells/Dormitory Nightlight	0.5 - 2		4
Toilets and washrooms	15 – 20		1
Shower rooms	15 – 20	3	1,2
Dayrooms	15 – 30	5	3
Corridors	15 – 20	3	1,2
Dining	15 – 20		1
Kitchen and Food Prep	50		1

1 Horizontal value provided by IESNA Lighting Handbook 8th Edition. 2. Vertical values provided by IESNA Lighting Handbook 9th Edition. 3. Horizontal and vertical values provided by IESNA Lighting Handbook 9th Edition. 4. Requirements not addressed by IESNA, ACA or DOC.

## SPACE-TYPE DESIGN GUIDELINES

### JAIL CELLS AND DORMITORIES

Provide reasonably uniform ambient lighting of about 20 average maintained footcandles. Locate fixtures so that higher light levels (30 average maintained footcandles) are available for reading, on the desktop in cells and over the pillows on beds in dormitories. Luminance ratios should be about 3:1 maximum to minimum, although the limitation of one luminaire per cell may result in maximum to minimum luminance ratios closer to 5:1. Consider installing a separate “security” type wall-mounted reading light at the head of the bed in a cell. Night lights should be low output (1 to 2 fc) using sources such as T2 fluorescent or compact fluorescent. A separate lamp installed within the high-security luminaires is a good method of uniformly distributing the night-lighting. Consider red lamps or red sleeves on those lamps dedicated for night-lighting.



If only one luminaire is used in a cell, locate it asymmetrically, if necessary, at the end nearest to the desk and head of bed.

### TOILETS, WASHROOMS, SHOWERS

Provide ceiling lighting with a uniform distribution, especially around partial height partitions. Fixtures should be rated for a wet location. Shield lights from dormitory areas to avoid sleep disturbance.

### CORRIDORS

Luminaires in corridors adjacent to cells should be located to be out of sight of the Corrections Officers surveying the cells. A uniform distribution of light improves visibility for personnel and electronic surveillance and eliminates shadows or hiding places. Corridors should have light-colored walls and ceilings. Consider two-level switching or high–low ballasts connected to occupancy sensors with a 20-minute time delay. This will save energy, especially at night, while maintaining a uniform distribution of 50% illumination for surveillance from booths or cameras, even when unoccupied.

## SECURITY STATIONS/SURVEILLANCE BOOTHS/“BUBBLES”

The ambient lighting should be lower on the inside of surveillance booths than in the area being watched. Local task lights or separately switched downlights can provide sufficient light for reading. Locate ceiling luminaires to reduce reflections on observation glass and computer/video screens. Shield source glare and use combinations of indirect light and task lighting. Avoid spill light from adjacent spaces and corridors and avoid direct glare from exterior windows

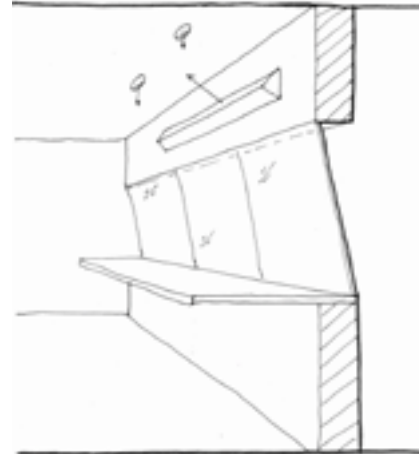

Improve visibility from inside Surveillance-Booth by:

- Sloped glass to reduce reflections
- Dimmable CFL downlights
- Uplighted ceiling at front of booth

## DAYROOM/RECREATION/LOUNGE

Locate lights or TV set to avoid reflections from windows, skylights or luminaires. Try not to exceed a 5:1 maximum to minimum luminance ratio. Provide daylight or view windows in some portion of the space.

## DINING ROOM

Provide daylight to the greatest extent possible but control direct sun penetration. Mount luminaires well out of reach of occupants and/or use vandal resistant luminaires. Locate some rows of luminaires close to walls, and space remaining rows for uniform distribution. Try not to exceed a 3:1 maximum to minimum luminance ratio. Walls, ceilings and furnishings should be light in color, 70% reflectance or higher, and no shinier than semi-gloss.

## VISITOR/FAMILY ROOM

Provide daylight to the greatest extent possible. Control direct sun penetration with exterior louvers or overhangs. Provide uniform lighting wall to wall that does not exceed a 5:1 maximum to minimum luminance ratio. To achieve such an even distribution, locate perimeter rows of fixtures near walls, and space remaining rows for uniform distribution. Coordinate luminaire layouts with windows and skylights to take advantage of daylighting controls.

## ELECTRONIC ARRAIGNMENT ROOMS

Lighting should follow the lighting design principles for typical teleconferencing environment. Luminaires should be located above and to sides of subject, shielded from cameras and monitors. A small amount of lighting behind the subject is preferable. 30 fc of light on the face is generally acceptable, but verify the light-level requirements of the specific camera. The lighting should be relatively uniform, with facial modeling provided from the side and back lights. Fluorescent sources are the best way to achieve the high vertical illumination. Use the same 78- 85 CRI lamps used elsewhere. Avoid harsh shadows or lighting angles that are unattractive and prejudicial. Luminaires within reach of occupants should be “security” type.



courtesy: STV Architects

## EXTERIOR ACTIVITY YARD AND PERIMETER SURVEILLANCE

Control angle of light for best viewing from surveillance locations, including guards and cameras. Reduce light pollution to the sky and light trespass into the community. Consider energy conservation issues, and use multiple level controls for different levels of security. Consider the use of two-level high-low ballasts for metal halide lamps in order to get a quick response to full on in case of emergency.

Control exterior lights so that they can be reduced during hours of no activity, but immediately restored in case of emergency.

## ENERGY EFFICIENCY STRATEGIES

Specific Strategies for Energy Conservation in Correctional Facilities

- Light colored finishes contribute through interreflections
- Very efficient sources since they will operate for long hours
- Lighting controls that provide multiple levels
- Daylight harvesting
- Improve uniformity rather than over-lighting spaces
- Distribution of light to wall to give sense of brightness

## ENERGY CODES: WATTS / SQUARE FOOT BUDGETS

FUNCTION	NYS ENERGY CODE		ANSI/ASHRAE/IESNA STD.90.1		NOTES
	2002	+/- 2007	1999 / 2001	2004	
“PENITENTIARY” BUILDING (Building Type Method Only)		<b>1.0</b>	<b>1.2</b>	<b>1.0</b>	1,3
Cells/Dormitory			<b>1.1</b>	<b>0.9</b>	2,3,4
Toilets and Washrooms	0.8	0.9	<b>1.0</b>	<b>0.9</b>	2,4,5
Shower rooms	0.8	0.9	0.8	<b>0.6</b>	2,4,5
Dayrooms			1.4	1.2	2,3
Corridors	0.8	0.9	0.7	0.5	2,4,5
Classrooms	1.6	1.4	<b>1.4</b>	<b>1.3</b>	2,4
Audience/Seating Area	1.6	1.8	<b>1.9</b>	<b>0.7</b>	2,4
Dining	1.4	0.9	<b>1.4</b>	<b>1.3</b>	2,4
Other	1.0	1.0			

1. Multiply this value by the total square footage of the building, to determine the total building interior power allowance, using the Building Type method. 2. Multiply this value by the square footage of the dedicated space function. Sum the results of all the individual spaces in the building to determine the total building interior power allowance using the space-by-space method. The design of an individual space is not required to meet the watt/sf limits, as long as the total building connected load does not exceed the total interior power allowance. 3. Function category not listed in NYS Energy Code. 4. Values are for the space type but are not specific to penitentiary-type facilities. **Values in bold are specifically for “penitentiary.”** 5. NYS Energy Code values are from “Corridor, restroom, support area” category.

## LIGHTING CONTROLS

To maintain security, no area of a correctional facility should be entirely darkened, and when light levels are reduced, uniform distribution should be maintained. “Panic switches” for emergencies should turn the lights on to full. Work closely with the specific facility to achieve the correct balance of in-mate control, automatic control, staff control and overrides.

Generally, all cells, dormitories and dayrooms are connected to master on-off switches controlled by the Corrections Officers from within the surveillance booth. Automatic timers may be appropriate for turning some of the lights on or off on a regular schedule to maintain a routine by signaling that the sleeping period is ending or about to begin, but this should be discussed with the management. Multiple-level switching is often appropriate, based on daylight availability and occupancy. In addition, some level of night lighting must be provided in a relatively uniform pattern. There are different control strategies for different areas.



courtesy: STV Architects

Multiple-level switching works well for dayrooms. The highest light levels should be reduced at night or when the space is unoccupied.

## CELLS

There are reasons to provide multiple-level lighting control to individual cells. Lawsuits have been brought on behalf of inmates requiring at least 30 footcandles of reading light on the desk top, or at the head of the bed. On the other hand, luminaires have been vandalized by inmates attempting to reduce the light levels in their cells. Since multiple luminaires or multiple lamps are required to light a jail cell, it is feasible to have two-level switching capability. At the most basic level, a switch outside the cell (out of reach) can be used by the staff to set a desired full-time light level for each cell occupant. Another strategy is to provide a tamperproof “bolt” switch inside the cell controllable by the occupant, to reduce the lighting in the cell by 1/2 or 2/3. (See Luminaire Schedule). This degree of occupant control may improve morale and reduce vandalism of cell lighting fixtures. Finally, night lights incorporated into the luminaires can be connected to momentary contact bolt switches on the outside of the cell, so that a Correctional Officer can look through the surveillance window, briefly turn on the night light, and move on to the next cell, with minimal or no disturbance to sleeping inmates.

## DORMITORIES

Where daylighting provides at least 30 fc for 50% of annual daytime hours, consider photocell-operated switching or dimming controls for dormitories. Night lighting should be no more than 1 fc and uniformly distributed. Glare from adjacent areas must be controlled so that the eyes of the ambulatory guard can adapt to the nightlight level, using a flashlight as supplementary lighting. If desired, an increase to 2-4 fc can be available via separate switches, zoned for short-term surveillance.

## DAYROOMS

Consider at least two levels of uniformly distributed ambient lighting, (one level can be switched or dimmed by daylight sensors during the day and by inmates at night) and a separate night-lighting level for ambulatory Corrections Officers or for surveillance from booths. Consider supplying supplemental reading lights (using “security” type luminaires) at a few locations for older or visually-impaired inmates.

## TOILETS, SHOWERS

Consider two-level switching or high-low ballasts connected to occupancy sensors with 20-minute time delay, so lighting levels do not exceed 50% (33% preferred) when spaces are unoccupied. Shield the lights from the dormitories, to minimize sleep disturbances caused by changes in luminaire output at night.

## CORRIDORS

Consider two-level (33%-100%) switching activated by occupancy sensors with a 30-minute time delay.

## SURVEILLANCE BOOTHS

Consider multiple-level switching and separate task lighting controls, accessible to the guards. It should never be possible to turn off all the lights, but very low light levels (2-10fc) should be possible for booths within dormitories at night. The lower the light levels are within the booths, the easier it is for the Correctional Officers to see into the darkened dormitories.

## DINING ROOM

Consider a photocell-controlled switching strategy to turn off lights when daylight is 30 fc or higher. Provide multiple levels of controls accessible only to staff by key or restricted location.

## VISITOR-FAMILY ROOMS

If daylight exceeds 50 fc for more than 30% of daytime hours, consider a photocell-controlled multiple level switching or dimming system. Specify luminaires with two level ballasts or in-line two-level switching. Circuit luminaires in zones that correspond to space functions and daylighting distribution.



## EXTERIOR ACTIVITY YARD AND PERIMETER SURVEILLANCE

Consider the use of two-level high-low ballasts for metal halide lamps in order to get a quick response to full-on in case of emergency.

## SPECIAL CONSIDERATIONS FOR ADULT DETENTION FACILITIES

### “SECURITY” TYPE LUMINAIRES

Special luminaires are available specifically for use in maximum-security areas. It is assumed that they are installed into or attached to ceilings and walls that are equally vandal-resistant. “Security” type luminaires share several goals:

- Sturdy construction to prevent disabling of the light or destruction of the luminaire. (See Sample Luminaire Schedule at the end of this Brief for material requirements).
- Tamperproof construction and tight mounting to surfaces, to avoid prisoner access to electricity, hiding places for contraband or the use of parts for weapons.
- Smooth edges so they cannot be used as tools.

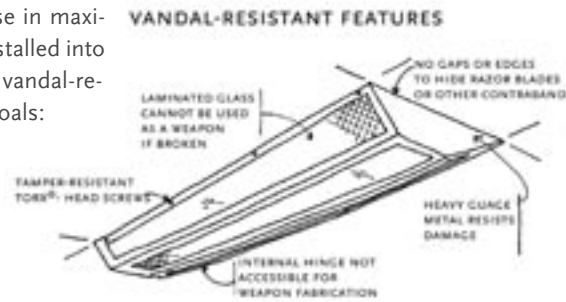

### LIGHT LOSS FACTOR

Although maximum-security luminaires are enclosed and tightly constructed, they are not airtight, and are prone to dirt buildup. In addition, inmates have been known to obscure the lenses in their cells (with ink-impregnated toothpaste, or paper and tape) in order to physically reduce the light transmission. While the room surfaces in correctional facilities are usually kept quite clean due to inmate labor, the electrical devices must be cleaned by electricians or staff maintenance. At the very least, it should be assumed that luminaires are cleaned when lamp burnouts are replaced. In spite of the above it is recommended that a light loss factor of 0.70 or higher be used in calculating “maintained” illuminance for correctional facilities, to save energy and avoid excessive oversizing of the lighting system. The “High Performance” T8 lamps recommended for all DDC facilities extend lamp life, and also retain over 90% of their initial output for a much longer time.

### EMERGENCY AND SECURITY LIGHTING

Jail facilities in New York City are required to have redundant emergency systems and backup generators. In addition, DDC requires battery backup in emergency lights. Verify that any lighting controls will default lamps to on in case of control equipment failure.

### EXTENDED LIFE AND FREQUENTLY SWITCHED LAMPS

Due to the tamper-proof construction and security restriction for maintenance, every effort should be made to extend lamp life in correctional facilities. “High Performance” T8 lamps are available in “extended life” versions that increase the rated lamp life to 24,000 hours or more. Fluorescent lamps that are subject to more than five on-off cycles per day should be operated on multi-level ballasts, which keep the lamp cathodes warm at the lowest setting, or on programmed-start ballasts, which soften the impact of the starting voltage. Both technologies protect the lamps from premature burn-outs under conditions of frequent switching.

## **SPECIAL COMMISSIONING CONSIDERATIONS**

For obvious reasons of security, commissioning of lighting systems must be done prior to occupancy of correctional facilities.

## **VERIFICATION**

Emergency equipment, such as standby lighting, batteries, power generators, and alarms should be checked frequently to ensure their reliability.

## **GROUP RELAMPING**





Group re-lamping makes a lighting system more efficient by keeping light output closer to design levels. It also saves significantly on labor costs. However, the difficulties of vacating secure areas for lengthy time periods or acquiring security clearances for maintenance crews will likely override the concerns for cost savings.

For reduced energy consumption, the following four-foot long fluorescent lamps are the DDC standard: 32 Watt T8, 3,100 lumen, CRI 85+, 3500 Kelvin, low mercury, extended life (24,000 – 30,000 hours). Note that DCAS (NYC Department of Citywide Services) will have available one of the following lamps: GE #F32T8 XL SPX35 HLEC (10326); Philips #F32T8/ADV/835/ALTO (13988-1); Osram/Sylvania #FO32/835/XPS/ECO (21697).

## SAMPLE LUMINAIRE SCHEDULE FOR ADULT DETENTION FACILITIES

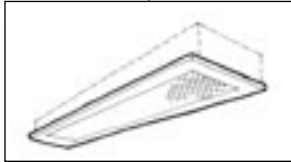
### “SECURITY”-TYPE LUMINAIRES: MATERIAL REQUIREMENTS

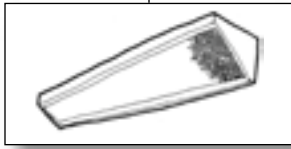
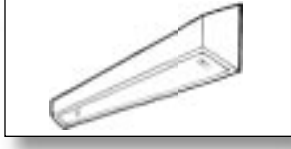
- Cold Rolled Steel. White painted; high reflectance polyester powder coat baked finish.
  - Minimum Security – 18 ga steel
  - Medium Security – 16 ga steel
  - Maximum Security – 14 ga steel
  - Ultramax Security – 12 ga steel
- Glass: 1/2" thick laminated glass assembly, two layers of tempered glass each 1/4" thick. Prismatic glass on cell side and clear glass on lamp side. No acrylic or polycarbonate layers.
- Fasteners: TORX® -head tamper-resistant screws

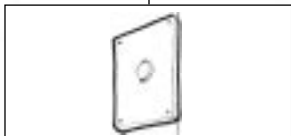
	<p><b>FLUORESCENT 1'X4' LENSED FIXTURE, RECESSED OR SURFACE-MOUNTED</b></p> <p><b>Location:</b> Cells, dormitories, corridors, dayrooms, toilets, shower rooms  <b>Lamps:</b> (2 or 3) 28-32W, High Performance T8, 835 – 850 color  <b>Description:</b> Recessed or surface-mounted luminaire, integral compact fluorescent night light (7-9w) in sleeping areas. Damp or wet label where appropriate.</p>
	<p><b>SURFACE MOUNTED WIDE-DISTRIBUTION LUMINAIRE</b></p> <p><b>Location:</b> Cells, dormitories, dayrooms, corridors, toilets, shower rooms  <b>Lamps:</b> (3) 28-32W, High Performance T8, 835 – 850 color  <b>Description:</b> Fluorescent luminaire with completely concealed piano hinge. One lamp for each diffusing panel. Integral nightlight for sleeping areas. Wide distribution. Damp or wet label where appropriate.</p>
	<p><b>CORNER FLUORESCENT READING LIGHTS</b></p> <p><b>Location:</b> Cells  <b>Lamps:</b> (1) or (2) 17-32W, High Performance T8, 835 – 850 color  <b>Description:</b> 2', 3' or 4' long luminaire, mounted above desk and/or bed. Completely concealed piano hinge.</p>
	<p><b>CORNER FLUORESCENT</b></p> <p><b>Location:</b> Stairwells, corridors, toilets, shower rooms  <b>Lamps:</b> (2) 28-32W, High Performance T8, 835 – 850 color  <b>Description:</b> Completely concealed piano hinge. Damp or wet label where appropriate.</p>
	<p><b>WALL-MOUNTED FLUORESCENT DIRECT/INDIRECT</b></p> <p><b>Location:</b> Guard surveillance booths  <b>Lamps:</b> (2) 28-32W, High Performance T8, 835 – 850 color  <b>Description:</b> Uplight 30% - Downlight 70% .</p>
	<p><b>METAL HALIDE DOWNLIGHT, RECESSED OR SURFACE-MOUNT</b></p> <p><b>Location:</b> Dayrooms (two or three stories)  <b>Lamps:</b> (1) 70W-150W ceramic metal halide, 3200 – 5000 Kelvin  <b>Description:</b> Lens secured by through-studs. Completely concealed piano hinge. Emergency restrike capability.</p>
	<p><b>TOUCH™ BOLT™ SWITCH</b></p> <p><b>Description:</b> Stainless steel. Touch bolt. Security-type on-off switch.</p>

# WAREHOUSE & STORAGE FACILITY DESIGN BRIEF

The NYC Department of Design and Construction (DDC) manages the construction and renovation of NYC’s municipal buildings, many of which contain warehouse and storage facilities. While different in function, these spaces share characteristics that suggest a similar approach to lighting design, including high open spaces, a pattern of tall storage units and open aisles, and the need to easily identify stored items. These guidelines are intended for light industrial buildings, but may have application to similar storage spaces in other building types such as offices, schools, retail, correctional facilities or other institutions.

## LIGHTING QUALITY STRATEGIES

Warehouse and storage facilities have specific considerations because of their function and spatial characteristics. Please review and use these strategies, in concert with the basic design and quality issues discussed earlier in the Design Strategies section of this manual.

### WAREHOUSE-SPECIFIC LIGHTING QUALITY AND QUANTITY ISSUES

ISSUE	IMPORTANCE
Relationship between light source and visual task and viewer	Very Important
Glare Control – Direct and Reflected Glare	Important
Daylight Integration	Important
Uniformity – No Shadows	Somewhat Important
Three-dimensional modeling of objects	Somewhat Important
Luminances of Room Surfaces	Somewhat Important

From the IESNA Lighting Handbook, 9th Edition.



courtesy: Lighting Research Center, RPI, Delta Publications

Tall shelving units must be considered in lighting calculations.

#### Relationship Between Light Source and Visual Task and Viewer

The relationship between the light source, the visual tasks and viewer is very important in warehouse because the tasks are usually on the vertical plane, and above eye level. Searching for an item on a high shelf is a task subject to direct glare (looking into the light source) or veiling reflections which obscure labels or writing on shiny or glossy surfaces.

#### Glare Control

The most common glare problems in warehouses occur from “veiling reflections” (i.e., reflections of light sources on shiny or glossy materials) on objects or their labels, and direct glare from luminaires or skylights when seeking objects above eye level.

#### Daylight Integration

Daylight can provide high levels of relatively uniform light appropriate for warehouse functions. Because warehouses are often one-story buildings they can be uniformly daylighted from the roof. In particular, consider diffuse (frosted) skylights, north facing monitors or clerestory windows. Control glare and sun patterns, and don’t overlight, to avoid undesirable heat gain and glare. See References for simple guidelines and software for skylight design in warehouses.

#### Uniformity

A wide range of illumination is unavoidable in most warehousing applications because of the difficulty of distributing light from top to bottom on vertical shelving. This is acceptable as long as the transitions are gradual. Harsh shadows make the job of retrieval much harder. Luminance ratios should be no more than 20:1 between the top and bottom vertical face of shelving, or between the darkest and lightest surfaces in view.

### Three-dimensional Modeling Of Objects

Lighting to enhance the modeling of objects is only important when the correct selection of an object is dependent on its shape or texture more than its labeling. For example, the identification of nuts, bolts, plumbing connections, or fabrics might be faster by perusing the objects rather than labels. Modeling is enhanced by an increase in directional light over diffuse light, but even a diffuse light source such as fluorescent can provide adequate modeling if located in the right relationship of the light source to the object and the viewer.

### Luminance Of Room Surfaces

**Reflectances and Finishes:** To reduce the contrast and promote inter-reflections, every surface in view, and within the control of the design team, should be as light-colored as possible. Warehouses typically do not have finished ceilings, so use white-covered batt insulation, and/or paint exposed ceilings, structure, ductwork and other overhead obstructions white, especially near skylights. Shelving should be white, including the underside of shelves above eye level. Finishes should be eggshell or semi-gloss. Avoid metallic or shiny finishes. If natural metal is required, use a heavily brushed finish.

### Flicker

Lamp flicker can be dangerous in an industrial environment, especially in industrial applications with low speed motors that may have similar frequencies. Use high-frequency electronic ballasts to prevent fluores-

#### TASK DIFFICULTY AND LIGHT LEVELS



In storage and warehouse spaces, the most common visual tasks are locating the area where an object might be, locating the specific object, and retrieving it. Most storage tasks are on the vertical plane (shelving) rather than on the horizontal plane (countertops or flat files). An understanding of the specific details of the facility's operations should be known before designing the lighting.

#### REDUCING THE NEED FOR LIGHT

A visual task can be made easier not only by illumination, but also by:

- Improved task contrast (black letters on white background or white letters on black)
- Larger point size, bold print, upper and lower case letters
- Color contrast
- Locating objects at close proximity to viewer
- More time
- Familiarity with the task or the objects

#### FAMILIARITY

Regarding the last point, it is useful to know whether a knowledgeable employee or the general public will be performing the retrieval tasks. Full-time employees hired to retrieve materials from library archives or run a forklift in a warehouse are going to be less reliant on illumination to perform search tasks than the general public searching retail shelves for a product or library stacks for a book.

#### LOCATION OF LABELS OR OBJECTS

It will require less illumination to retrieve small objects at close range than to read small labels on a high shelf. It will be more difficult to distribute light deep into shelves and cabinets than to light boxes or labels that are flush with the face of the shelving.

cent or metal halide sources from flickering. Defective or failing ballasts that create lamp flicker should be replaced immediately.

### Color

Color can play an important role in object identification and good color rendering light sources will aid in visibility. Also, the warehouse may be part of a building type where good color rendering is desired for other tasks, and it is good practice to minimize the number of lamp types. The DDC requires the use of lamps with a CRI of 84 or higher. A correlated color temperature of 3500 to 5000 Kelvin is appropriate for warehousing functions.

### LIGHT LEVELS RECOMMENDED AVERAGE MAINTAINED ILLUMINANCE, IN FOOTCANDLES (FC)

FUNCTION	TASK FC - HORIZONTAL OR VERTICAL	LOCAL TASK LIGHTING TYPE
Active Storage, fine	30	Local
Active Storage, bulky	10	
Aisles	5	
Loading docks	10	Articulated

From the IESNA Lighting Handbook, 9th Edition.

## DESIGN AND LAYOUT STRATEGIES

### LAYOUTS

Fluorescent lighting is a good choice for warehouse and storage facilities. It is diffuse, linear and energy efficient. Most important, fluorescent sources are easily controlled with occupancy sensors and photocells, and restrike instantly for emergency usage. New luminaires designed for this application are replacing metal halide as the source of choice for many warehousing projects, even in high bay applications (ceilings above 25'). Luminaires should be closely spaced and located over aisles. (See Layouts). Fluorescent luminaires are available with quantities of 4, 6, or 8 lamps for either T8 or T5 sources. Luminaire distribution should be designed for stack or aisle lighting. Because of the narrower diameter of T5 sources, reflectors can be tailored to the lamp to achieve more precise beam patterns.

### OBSTRUCTIONS AND SPACING CRITERIA

Calculations must take into account the obstructing and absorbing characteristics of shelving units. This guide assumes that warehouses have exposed ceilings, with a height of 15' to 25' above the floor. Luminaires should be pendant-mounted, so a small percentage (5-10%) of the light can be directed to the ceiling, and located to avoid shelving and other obstructions from ceiling structure and mechanical equipment.

### TASK LIGHTING

Applications where local task lighting might be appropriate for storage and warehouse functions include fine storage, for searching deeply into shelves or cabinets, or for looking into trucks on loading docks.

### SPECIALIZED LUMINAIRES

Fixtures adjacent to outside air and temperature swings near warehouse doors or loading docks should be listed for damp label and utilize ballasts appropriate for the potential temperature extremes. In general, all luminaire housings should be white or lightly colored to reduce contrast and glare.

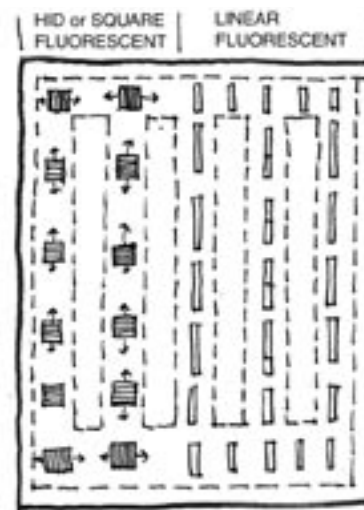

Luminaires and skylights should be located over aisles.

## PREVENT BREAKAGE

Lighting fixtures should be kept out of reach of moving ladders, lifts and materials. Lamps should be protected from breakage by lenses or cages. Sturdier fluorescent lamps are available for conditions of extreme vibration.

## ENERGY EFFICIENCY STRATEGIES

### WAREHOUSE-SPECIFIC ENERGY CONSERVING DESIGN STRATEGIES

- Evaluate tasks for potential improvements. For example:
  - Cluster tasks with similar visual needs together.
  - Separate bulk storage and fine storage areas. Consider local lighting for fine storage items.
  - Separate active storage and inactive storage. Control lights separately.
  - Color-code shelving and/or products.
  - Use large, high-contrast labels on shelving and products.
- Use daylighting to the greatest extent possible. If the warehouse is a one-story facility or is on the top floor, it is fairly easy to fully daylight the warehouse during most seasons and times of day using a grid of skylights. Choose the most diffusing material available for skylights. There is currently no precise language that can be used to specify good diffusion, thus diffusion is best assessed by direct visual inspection. For example, sunlight passing through the diffusing glazing material should not concentrate the light into local hot spots, nor cast a discernable shadow from a hand held three feet above the ground.
- Consider SkyCalc™ software to assist in the selection and placement of skylights, in order to optimize energy performance for a given layout and skylight-to-floor-area ratio (SFR). (See References).
- Control electric lights to reduce energy consumption.

### ENERGY CODES: WATTS / SQUARE FOOT BUDGETS

FUNCTION	NYS ENERGY CODE		ANSI/ASHRAE/IESNA STD.90.1		NOTES
	2002	+/- 2007	1999/2001	2004	
WAREHOUSE BUILDING (Whole Building Type Method Only)	0.6	0.8	1.2	0.8	1,3
Warehouse, Active Storage, fine materials			1.6	1.4	2
Warehouse, Active Storage, medium / bulky materials	1.0	0.8	1.1	0.9	2,4
Warehouse, Inactive Storage			0.3	0.3	2

1. Multiply this value by the total square footage of the building, to determine the total building interior power allowance, using the Building Type method. 2. Multiply this value by the square footage of the dedicated warehouse spaces. Sum the results of all the individual spaces in the building to determine the total building interior power allowance using the space-by-space method. The design of an individual space is not required to meet the watt/sf limits, as long as the total building connected load does not exceed the total interior power allowance. 3. Listed as "Storage Building, industrial and commercial," in NYS Energy Code. 4. Listed as "Storage area, industrial and commercial," in NYS Energy Code.

## LIGHTING CONTROLS

Provide multiple levels of controls. Occupancy sensors should only be used in a multiple level design, so that 5-10% of lights remain on after dark, but while the building is still occupied.

Provide daylight-compensating multiple-level switching with photocells located in skylight wells or adjacent to clerestories. Design the control system to prevent “cycling” of lamps on and off. No electric lights should be switched off until daylight alone provides at least 20% more than the desired illumination. See Technologies Section for daylighting controls.



North-facing monitors enable daylight to be the primary light source for the warehousing functions at Sunrise Yards, a current DDC project in Queens, NY.

## OTHER CONSIDERATIONS

Locate storage racks, luminaires and skylights in relationship to each other so daylighting is maximized and luminaires are accessible from aisles for maintenance.

Night-lighting or weekend lighting should be off or minimal in buildings with long hours of no occupancy.

### Dirt Depreciation

If the warehouse is open to the exterior, or if activities generate a high proportion of dust, the output of lamps and luminaires may be significantly depreciated due to dirt accumulation. Luminaires with open tops can reduce dirt accumulation by means of convection air currents. Annual cleaning and scheduled group relamping at 70% of rated lamp life can offset these losses. Avoid using excessively conservative light loss factors and overlighting the space.

### Emergency Lighting

The design of the emergency lighting system should take into consideration the extensive blocking of views caused by the shelving units and storage materials in a warehouse.

For reduced energy consumption, the following four-foot long fluorescent lamps are the DDC standard: 32 Watt T8, 3,100 lumen, CRI 85+, 3500 Kelvin, low mercury, extended life (24,000 – 30,000 hours). Note that DCAS (NYC Department of Citywide Services) will have available one of the following lamps: GE #F32T8 XL SPX35 HLEC (10326); Philips #F32T8/ADV/835/ALTO (13988-1); Osram/Sylvania #FO32/835/XPS/ECO (21697).



## SAMPLE LUMINAIRE SCHEDULE FOR WAREHOUSE & STORAGE FACILITIES

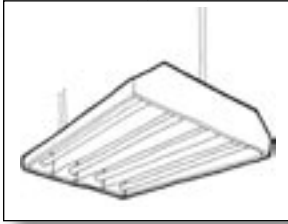

### FLUORESCENT LOW BAY ASYMMETRICAL PENDANT

**Location:** Warehouse  
**Lamps:** (4 to 6) 32W, High Performance T8 or 54W T5HO, 835 - 850 color  
**Description:** Pendant-mounted, open metal reflector housing. Instant-start, energy efficient multi-lamp ballasts. Mount a maximum of 30' above the floor. Minimum 90% efficiency.



### METAL HALIDE LOW-BAY AISLE LIGHT

**Location:** Warehouse  
**Lamps:** (1) 250W, ED-18 ceramic metal halide, 3200 – 5000 Kelvin  
**Description:** Pendant-mounted, anodized, spun aluminum reflector and precision injection-molded prismatic acrylic refractor provide multiple distribution patterns for precise control. Open metal reflector housing. Ceramic metal halide. Mount a maximum of 25' above the floor. Minimum 68% efficiency.

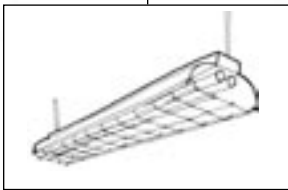

### PENDANT FLUORESCENT INDUSTRIAL STRIP WITH SLOTTED REFLECTOR WITH CAGE

**Location:** Warehouse, storage  
**Lamps:** (2) 28-32W, High Performance T8, 835 – 850 color  
**Description:** Pendant mounted fluorescent fixture, wired for continuous runs per row. White baked enamel reflector finish. Slotted for 20% uplight. Minimum 92% efficiency.

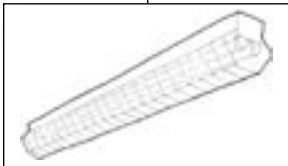

### INDUSTRIAL CHANNEL WITH CAGE

**Location:** Warehouse, storage  
**Lamps:** (2) 28-32W, High Performance T8, 835 – 850 color  
**Description:** Suspended or surface-mounted fluorescent strip fixture, wired cage to protect lamps. White baked enamel finish. Minimum 89% efficiency.

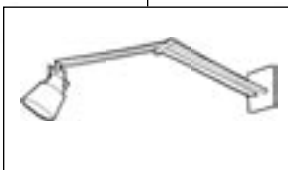

### LOADING DOCK LIGHTS

**Location:** Loading Dock Wall  
**Lamps:** (1) 60W Par-38 Halogen  
**Description:** Surface-mounted, adjustable-arm in three axes for aiming into truck beds. Powder-coated yellow for safety.

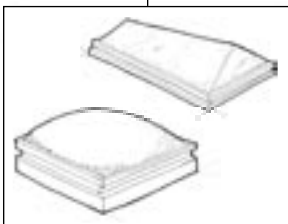

### SKYLIGHT

Double-glazed, non-venting plastic unit skylights with condensate gutter attached to integral, insulating frame. Glazing Material: Choose highest light transmittance available. 70%+ visible light transmittance recommended. Require proof from unit manufacturer that light transmission will remain stable over life of the unit, without yellowing or loss of structural strength. Maximum diffusion: Clear diffusing materials include prismatic acrylic, clear fiberglass, and complex polycarbonate extrusions. Heat Gain and Loss: Solar Heat Gain Coefficient = 70% maximum. Unit U-factor = 1.0 maximum (including framing effects). Safety & Maintenance: Check local fire and safety codes for minimum strength and other performance requirements. Include a safety grate to prevent forced entry or accidental falls. Occasional washing of the skylights in urban locations will help maintain optimal performance.

## WORKSHOP DESIGN BRIEF

The NYC Department of Design and Construction (DDC) manages the construction and renovation of NYC’s municipal buildings, many of which contain small industrial facilities such as carpentry shops, plumbing shops, electrical shops, auto maintenance shops, paint shops and the like. While different in function, these spaces share characteristics that suggest a similar approach to lighting design, including high open spaces, a variety of equipment or workstations, special concern for worker safety, and maintenance considerations. These guidelines are intended for these types of light industrial uses, but may have application to other similar space types.

### LIGHTING QUALITY AND QUANTITY STRATEGIES



courtesy: Lighting Research Center, RPI, Delta Publications

Fluorescent lighting reduces undesirable shadows

Workshops have specific considerations because of their function and spatial characteristics. Please review and use these strategies, in concert with the basic issues discussed earlier in the Design Strategies section of this manual.

#### WORKSHOP—SPECIFIC LIGHTING QUALITY AND QUANTITY ISSUES

General requirements for small industrial workshops: Provide uniform general ambient lighting. Use more fixtures with lower wattages to insure uniformity and reduce glare. Provide additional general lighting in limited areas with

more difficult task requirements. Provide local task lighting at benches and machinery when appropriate.

ISSUE	IMPORTANCE
Relationship between light source and visual task and viewer	Very Important
Glare Control – Direct and Reflected Glare	Very Important
Three-dimensional modeling of objects	Very Important
Luminances of Room Surfaces	Very Important
Uniformity – No Shadows	Important
Daylight Integration	Important
No Flicker	Important

From the IESNA Lighting Handbook, 9th Edition.

#### Relationship between light source and visual task and viewer

Because the visual task in workshops often involves materials that are shiny or glossy, or are combined with dangerous machinery, the relationship of the light source to the task and to the viewer is extremely important to avoid direct glare or veiling reflections. Local task lighting is often the best strategy to insure the proper physical orientation between the light source, visual task, and the viewer.

#### Glare Control – Direct and Reflected Glare

Certain workshop tasks require more glare control than others. Visually disabling glare can be hazardous in such environments because of dangerous machinery, finer tasks and visual obstructions. Distribute light to ceilings (5%-10% uplight) to reduce contrast from bright luminaires. Provide glare shielding in the 45 to 85 degree zone (See “cutoff angle” in Glossary). Polished or machined metal can produce disabling reflected glare. Use task lights at an angle to offset glare.

### Three-dimensional Modeling of Objects

For some tasks in workshops, such as painting or sanding or assembly, the ability to see three-dimensional form or texture makes visual performance easier. Modeling is enhanced by an increase in directional light in relation to totally diffuse light, and may be accomplished with diffuse sources, such as fluorescent, just by the correct placement of the sources in relation to the task. The angle should create slight shadows and enhance definition, rather than flattening the appearance of an object. Too much directional light should be avoided, as it creates harsh shadows that detract from seeing, and may actually be dangerous in conjunction with moving parts. Local task lighting combined with diffuse ambient lighting is an effective way to provide adequate definition of three-dimensional form. Lights that are adjustable in position and in the control of the worker are usually preferred on workbenches. Manufacturers of machinery often provide integrated task lighting that is designed for the function.

### Luminances of Room Surfaces

Luminance ratios should be close to uniform, not exceeding 1:6 ratio between the average and maximum luminance of room surfaces, or 6:1 ratio between minimum and average. The task should typically have the highest luminance in the field of view.

### Uniformity – Minimize Shadows

For safety purposes, harsh shadows should be avoided in workshops, especially near machinery. Machines and objects may obstruct the light, so diffuse sources should be used to promote uniform ambient lighting.

### Reflectances and Finishes

In order to achieve the desired luminance ratios and uniformity, reflectances should be high and finishes should be matte. Ceilings should be a minimum of 80% reflectance (90% preferred). Walls should be a minimum of 70% reflective, equipment and workbenches between 35 and 65% reflective, and floors not less than 20% reflective. Polished, glossy and shiny surfaces should be avoided, because specular reflections can reduce visibility and distract the worker. The most matte finish available that will provide acceptable maintenance should be used. Use matte or eggshell paints. Paint metal surfaces or use heavily brushed natural metal finishes.

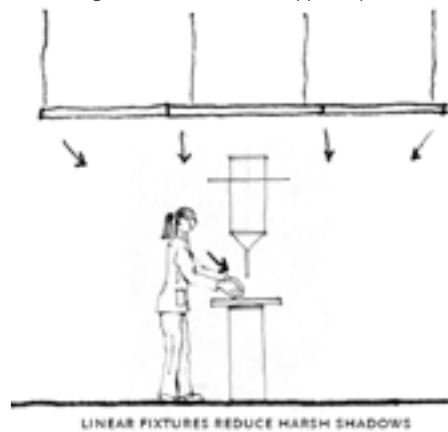

### Daylight Integration

Daylight can provide high levels of relatively uniform light appropriate for industrial activities. Because many shops are often in one-story buildings, they can be daylighted from the roof, with little to no electric light required during daylight hours. In particular, consider diffuse (frosted) skylights, north facing monitors or clerestory windows, or high perimeter windows in double height spaces. The visual connection to the out-of-doors can have a positive effect on work productivity. Control glare and sun patterns, using diffusers, fins or screens so that there are no dangerous patterns or distractions to the use of dangerous machinery or tools.

### No Flicker

Lamp flicker can be dangerous in an industrial environment, especially in industrial applications with low speed motors that may have similar frequencies. Use high-frequency electronic ballasts to prevent fluorescent or metal halide sources from flickering. Defective or failing ballasts that manifest lamp flicker should be replaced immediately. If only magnetic ballasts are available, the ballast should be circuited to different electrical phases than the motorized equipment in the workshops.

### Color

Use better color rendering lamps, with a CRI of 84 or higher. A correlated color temperature of 3500 to 5000 Kelvin is appropriate for most workshops. Good color rendering will aid in visibility. A special lighting comparison “booth” can be provided for color-matching paints. See the *IESNA Lighting Handbook* for specialized industrial applications.

## LIGHT LEVELS [RECOMMENDED AVERAGE MAINTAINED ILLUMINANCE, IN FOOTCANDLES (FC)]

SHOP TYPE	AMBIENT FC	BENCH / TASK FC	MACHINERY FC	STORAGE FC	LOCAL TASK LTG. TYPE
Plumbing	30	30-50	50	5-10	Undershelf
Electrical	30	30-75	-	5-15	Articulated
Carpentry	30	30-50	50-75	5	Undershelf, Articulated or Equipment-mounted
Metal	30	30-50	50-75	5-10	Undershelf
Auto Repair	30	30-50	50-75	5-10	Portable
Paint Shop	30	30-50	-	5-10	Undershelf*

Adapted from the IESNA Lighting Handbook, 8th and 9th Edition. \* special lamps may be required for paint matching.

## DESIGN AND LAYOUT STRATEGIES

### Obstructions and Spacing Criteria

Calculations for uniformity should incorporate a realistic assessment of the potential obstructions to the light distribution, such as machinery, vents, or stored materials that extend above the working plane. This guide assumes that the workshops are located in spaces with exposed ceilings, with a clear height of 15' to 25' above the floor. Luminaires should be pendant-mounted (so that 5-10% of the light can be redirected to the ceiling) and located to avoid obstructions from ceiling structure and mechanical equipment.

### Task Lighting

Local task lighting should be provided for tasks requiring significantly higher light levels, for inspection tasks, or for tasks that are obstructed from receiving ambient lighting. Task lights can be mounted on or above work benches, and are often available from equipment manufacturers. Depending on the specific conditions, task luminaires should be fixed in the optimal position for task viewing and operator eye position, or should be articulated in three directions to allow full adjustability by the operator. Consider task lights that are combined with optical magnifiers. Portable task lighting should be provided for auto repair and loading docks, where it is necessary to look under or into objects. Use fluorescent or LED sources, to minimize heat or burning hazard. Lamps should be protected with guards, and be suitable for vibration and rough handling.

### Specialized Luminaires

In addition to the typical industrial luminaires shown in the Fixture Schedule below, there are also specialized luminaires manufactured that are explosion proof, or appropriate for hazardous conditions or wet locations, or "clean rooms". Areas with vibration may require luminaires with safety cages, flexible socket sleeves, vibration resistant lamps, etc. Areas with intense dirt generation may require luminaires that are sealed and gasketed with breathable filters, although the extra expense should be justified. In general, all luminaire housings should be white or lightly colored to reduce contrast and glare.

### Safety

Not only should the space be lighted for intended task performance, but the design should also adequately illuminate any potential dangers or hazards in the building. Paths of egress and layouts should be carefully designed in spaces where protective eyewear, tinted lenses, face guard and use of respirators reduce amount of light reaching the eye. The recommended illumination levels listed below take protective eyewear into account.

Electrical cut-off "panic" switches for carpentry machinery are required in numerous accessible locations throughout carpentry shops and other workshops with moving equipment.

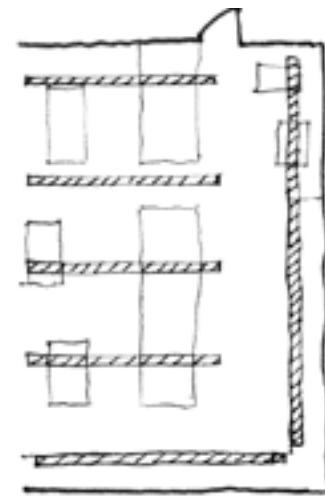

LOCATE AMBIENT FIXTURES OVER WORK BENCHES AND/OR PERPENDICULAR TO TABLES

## ENERGY EFFICIENCY STRATEGIES

### Workshop-specific Strategies

- Evaluate tasks for potential improvements in contrast or background.
- Cluster tasks with similar visual needs together. Separate storage areas from task areas.
- Paint moving parts of machinery contrasting colors from stationary parts, to reduce accidents.
- For small, difficult tasks, use optical magnification to improve visibility.

### ENERGY CODES: WATTS / SQUARE FOOT BUDGETS

FUNCTION	NYS ENERGY CODE		ASHRAE/IESNA STD.90.1		NOTES
	2002	+/- 2007	1999/2001	2004	
WORKSHOP BUILDING (Whole Building Type Method Only)			1.7	1.4	1
Workshops (less than 20' ceiling)	2.1	1.2	2.5	1.9	2,3
Workshops (20' or higher ceiling)	3.0	1.7	2.5	1.9	2,3
Storage, Active	1.0	0.8	1.1	0.8	2
Storage, Inactive			0.3	0.3	2

1. Multiply this value by the total square footage of the building, to determine the total building interior power allowance, using the Building Type method. If no value is shown, use the space-by-space method. 2. Multiply this value by the square footage of the dedicated workshop spaces. Sum the results of all the individual spaces in the building to determine the total building interior power allowance using the space-by-space method. The design of an individual space is not required to meet the watt/sf limits, as long as the total building connected load does not exceed the total interior power allowance. 3. NYS Energy Code uses the title “industrial work” instead of “workshop”.

### Lighting Controls

Provide multiple levels of controls. Occupancy sensors should only be used in a multiple level design, so that the space cannot be totally darkened while a worker is performing a dangerous activity. Specify dual-technology occupancy sensors, to prevent false offs and ons. (See technology section)

For daylight compensating, dimming is preferred over switching because of hazardous machinery. However, for spaces where daylight provides the desired light levels for the greater majority of the day or year, a switching system may be a cost-effective choice. Special care should be taken to avoid large changes in light levels, or “cycling” of lamps on and off. (See Technologies Section for daylighting controls).

## OTHER CONSIDERATIONS

### Dirt Depreciation

Many light industrial activities generate a high proportion of dust, paint or air-borne particulates that adhere to lamps and luminaires as well as walls and other room surfaces. For the safety and health of



North-facing monitors and angled louvers ensure that daylighting is the primary source of light for the workshops at Sunrise Yard. The direct sunlight is never allowed to hit the work surfaces during work hours.

workers, as well as the efficiency of the lighting system, every effort should be made to reduce airborne pollution, including machinery-mounted vacuums and powdercoat paint processes. Depending on the application, luminaires with open tops and bottoms can reduce dirt accumulation by means of convection air currents. Clean lamps and lighting fixtures at least once a year. Enclosed and gasketed luminaires will keep the lamps cleaner, but still require cleaning of the external lens.

Wide distribution luminaires aids uniformity even when lamps burnout. Since spot-relamping is so difficult in a heavily obstructed environment, group relamping should be mandatory. Night and weekend lighting should be off or minimal in buildings with long hours without occupancy.

### Emergency Lighting

Special care should be taken to ensure all exits and paths of egress are clearly visible, in spite of machinery and obstructions in workshop settings.

### Temperature Extremes

It is not expected that the workshops types covered by this guideline will be outside of the range of normal interior temperature ranges. However, luminaires, ballasts and components do exist to accommodate extremes in temperature or humidity in industrial environments.

### Hazardous Area Classification For Luminaires

The design team engineers, in conjunction with the building owner, must determine if any spaces in the building are to be considered Hazardous (Classified) under the definitions of the National Electric Code or other provisions of the NYC Electrical Code. A Hazardous classification has an impact on all electrical equipment used in that space must be documented and made available for use by the design team members, the contractor, and building owners and maintenance personnel. Once the classification has been made, the specified luminaires must be Hazardous-rated to meet the requirements of that specific Class, Division and Group.

RISK	AREA CLASSIFICATION	BASIC TYPE OF FIXED LUMINAIRE*
Normally flammable or volatile gases, liquids, or solids	Class I† Division 2	Explosion-proof
Occasionally hazardous volatile gases, liquids, or solids	Class I Division 2	Enclosed and gasketed
Normally combustible dust	Class II	Dust-ignition proof
Occasionally hazardous dust (grain, flour, wood, plastic, and chemical dusts)	Class II Group G Division 2 only	Enclosed and gasketed
Combustible fibers or flyings	Class III	Enclosed and gasketed

Courtesy The IESNA Lighting Handbook, 9<sup>th</sup> Edition, Chapter 19.

Note: The National Electric Code (NEC) sections 500-5, 500-6, and 500-7 recognize three classes of hazardous (classified) locations, based on the type of material involved. Within each class there are varying degrees of hazard, so each class is subdivided into two divisions. The classification by division is based on the likelihood the material will be present. The requirements for Division 1 of each class are more stringent than those for Division 2.

The materials in the three classes are defined as follow: Class I, flammable glass or vapors; Class II. Combustible dust; and Class III, combustible fibers or flyings.

Where a given location is classified as hazardous, it should not be difficult to determine in which of the three classes it belongs. Common sense and good judgement must prevail in classifying an area that is likely to become hazardous an in determining those portions of the premises to be classified Division 1 or Division 2.

\* The terms, explosion-proof, dust-ignition-proof, and enclosed and gasketed are generic types of [luminaire] construction only. The class, group, division, and operating temperatures must be known to select the appropriate luminaire that is Hazardous-rated for that classification.

† Group and temperature markings shown on the luminaire are used to determine its classification.

For reduced energy consumption, the following four-foot long fluorescent lamps are the DDC standard: 32 Watt T8, 3,100 lumen, CRI 85+, 3500 Kelvin, low mercury, extended life (24,000 – 30,000 hours). Note that DCAS (NYC Department of Citywide Services) will have available one of the following lamps: GE #F32T8 XL SPX35 HLEC (10326); Philips #F32T8/ADV/835/ALTO (13988-1); Osram/Sylvania #FO32/835/XPS/ECO (21697).

## SAMPLE LUMINAIRE SCHEDULE FOR WORKSHOPS

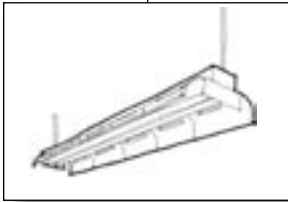

### PENDANT FLUORESCENT INDUSTRIAL STRIP WITH SLOTTED REFLECTOR

**Location:** Workshop  
**Lamps:** (2) 28-32W, High Performance T8, 835 – 841 color  
**Description:** Pendant mounted fluorescent fixture, wired for continuous runs per row. White baked enamel reflector finish. Slotted for 20% uplight. Minimum 92% efficiency.

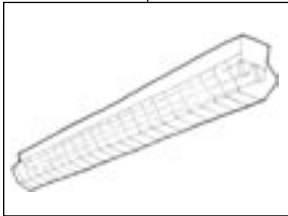

### FLUORESCENT INDUSTRIAL CHANNEL WITH CAGE

**Location:** Workshop  
**Lamps:** (2) 28-32W, High Performance T8, 835 – 841 color  
**Description:** Suspended or surface-mounted fluorescent strip fixture, wired cage to protect lamps. White baked enamel finish. Minimum 89% efficiency. Sealed, gasketed, and hazardous-rated if required.

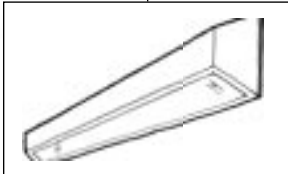

### WALL-MOUNTED FLUORESCENT DIRECT/INDIRECT

**Location:** Workshop  
**Lamps:** (2) 28-32W, High Performance T8, 835 – 841 color  
**Description:** Wall-mounted fluorescent fixture, wired for continuous runs per row. White baked enamel reflector finish. 50% minimum uplight. 50% downlight. Minimum 41% efficiency. Hazardous-rated if required.

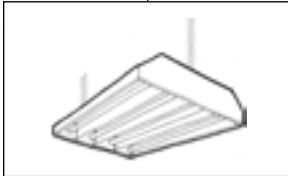

### FLUORESCENT LOW BAY PENDANT

**Location:** Workshop  
**Lamps:** (4 to 6) 32W High Performance T8 or 54W T5HO, 835 - 841 color  
**Description:** Pendant-mounted, open metal reflector housing. Instant-start, energy efficient multi-lamp ballasts. Mount a maximum of 30' above the floor. Minimum 90% efficiency.



### METAL HALIDE LOW BAY

**Location:** Workshop  
**Lamps:** (1) 250W, ED-18 ceramic metal halide, 3200 – 5000 Kelvin  
**Description:** Pendant-mounted open prismatic glass refractor housing with approximately 25% +/- uplight component. Field adjustable light pattern for medium to wide light distribution for various ceiling heights. Minimum 80% efficiency. Hazardous-rated if required.

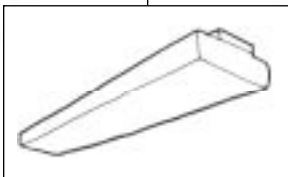

### FLUORESCENT WRAP-AROUND PENDANT/SURFACE-MOUNTED

**Location:** Workshop, storage  
**Lamps:** (2) 28-32W, High Performance T8, 835 – 841 color  
**Description:** Pendant or surface-mounted fluorescent wrap-around with injection molded clear acrylic plastic lens. Instant-start energy-efficient ballast. Minimum 81% efficiency.

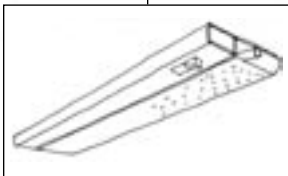

### UNDERSHELF FLUORESCENT TASKLIGHT

**Location:** Workbench  
**Lamps:** (1) 28-32W, High Performance T8, 835 – 841 color  
**Description:** Shelf-mounted linear fluorescent tasklight with solid front and clear prismatic acrylic lay-in diffuser.

## CORRIDORS & STAIRS DESIGN BRIEF

The NYC Department of Design and Construction (DDC) manages the construction and renovation of NYC's municipal buildings, all of which have circulation corridors, and most of which have stairs. This is intended for interior spaces, but has some application to exterior nighttime lighting.

### LIGHTING QUALITY STRATEGIES

Corridors and stairs have specific considerations because of their function and spatial characteristics. Many of them are the designated means of egress in case of emergency. Please review and use the guidelines below, in concert with the basic issues described earlier in the Design Strategies section of this manual.

### SPECIFIC LIGHTING QUALITY AND QUANTITY STRATEGIES

ISSUE	IMPORTANCE
Safety	Very Important
Shadows on stair risers and corridor surfaces	Very Important
Modeling of Faces or Objects	Important
Luminances of Room Surfaces	Important
Light Distribution on Surfaces	Important
Direct Glare	Important
Daylighting Integration and Control	Important

From The IESNA Lighting Handbook, 9<sup>th</sup> Edition

#### Safety

Any change in elevation increases the risk to pedestrians of stumbling or falling. This can happen in broad daylight, so lighting is not the only factor. The most important safeguard is to make sure the pedestrian is aware that the stairs are there at all. A single step is more dangerous than a flight of steps, because it is often overlooked. Stair awareness requires coordination between the architect and the lighting designer. At the very least, the top and bottom steps should be distinguished from the landing or adjacent paving, and this is best accomplished by changes in materials. Providing a bright contrasting color and textural change on the nosing of each tread is recommended for the elderly and visually impaired. The riser should be a slightly darker reflectance than the tread, to increase the differentiation between tread and riser. Lighting located at the top and bottom of a string of steps both announces the presence of a change in elevation, and enhances any contrast in material finishes. Once a pedestrian has found the first step, lighting visibility is only moderately important until the last step, as long as the tread and riser dimensions remain constant. The top and bottom of ramps should be treated like stairs.

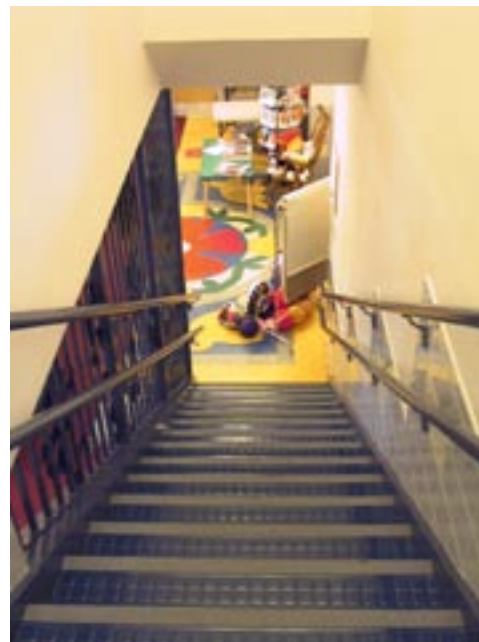

Lighter-colored band on nosing makes steps more visible.

courtesy: NYC Department of Design & Construction

In corridors, wall-mounted lighting fixtures can be hazardous to building occupants. The Americans with Disabilities Act (ADA) requires that any part of a luminaire below the height of 6'-8" shall not protrude into an egress corridor more than 4". This is intended to protect the blind from physical injury, but protects



everyone walking close to the walls, and is good practice even when a corridor is not the official path of egress. A large number of ADA compliant wall sconces are available nowadays. In general, distributing light to the walls rather than the floor aids pedestrian orientation better than directing the light down to the floor. Sharp shadows, shiny materials and randomly patterned carpets or finishes should be avoided, since they are disorienting, especially to the elderly or visually impaired. The architect can improve visibility by providing contrasting materials or colors at the junction of the floor and walls. While some non-uniformity in corridors is desirable to avoid monotony, the patterns of light and dark should be relatively gentle and never create confusion or disorientation.

### Shadows

In general, harsh shadows should be avoided in both corridors and stairs. They are not only disorienting, but they may obscure debris, obstructions or even people. Diffuse sources such as fluorescent luminaires, and light colored wall and ceiling finishes will create enough inter-reflections to prevent this. It should be noted, however, that properly placed shadows can help with the safe navigation of stairs. Lighting distributed from the top of the stairs, downward at the proper angle, can put the riser in shadow, and create a small shadow line at the back of the lower tread. This helps distinguish the bright nosing of each tread from the step below. This is easier to accomplish in exterior lighting applications.

### Three-Dimensional Modeling

Identifying other people as well as objects in corridors and stairwells is an important goal for both safety and civility. Lighting strategies that distribute light to all the space's surfaces will generally provide adequate facial modeling.

### Light Distribution on Surfaces

**Corridors:** Lighting designs should distribute light to the walls and ceilings rather than only to the floor. Such spaces will be perceived as brighter, consume less energy, and will be safer and more conducive to way-finding.

**Stairs:** Light should be distributed to the walls and steps, and indirect light on the underside of landings is also appropriate. Diffuse lighting located at the landings is usually the starting point, and may be the only lighting required.

### Glare Control

Glare not only causes discomfort but can diminish the ability to maneuver the stairs safely. Shiny surfaces should be avoided to prevent reflected glare.

### Uniformity

Light levels should be relatively uniform in stairways so that pedestrians can see the stair edges and see details in the shadows. By locating luminaires at the top and bottom of a set of steps, the higher light levels emphasize the changes in elevation. The same strategy can be used in corridors by locating luminaires at corners and intersecting corridors. However, luminance contrast should not be much greater than 5 to 1, to prevent changes in the eye adaptation level.

### Daylighting

Daylight is desirable in corridors and stairwells. It provides a welcome relief, views, and a connection to the outdoors. Some direct sun penetration may even be acceptable, as long as it does not have an impact on cooling loads, and does not cause disabling glare near changes in elevation.

### Color

In order to limit the number of lamp types on a project, the lamps used in corridors and stairs should be the same as used elsewhere.

## LIGHT LEVELS RECOMMENDED AVERAGE MAINTAINED ILLUMINANCE, IN FOOTCANDLES (FC):

FUNCTION	HORIZONTAL FC (AT FLOOR LEVEL)	NOTES
Corridors (active)	5	
Stairs (active)	5-10	1

From The IESNA Lighting Handbook, 9<sup>th</sup> Edition.

1. NYC Life Safety Codes may differ.

## DESIGN AND LAYOUT STRATEGIES

### CORRIDORS

There are a wide variety of acceptable lighting solutions for corridors. Upcoming energy code allowances will approximate an average of 36 watts every 15' for a five foot wide corridor, but this can be achieved in many different ways. In general, the types of luminaires used in office spaces will concentrate too many lumens and consume too many watts to be used effectively in corridors. The objective is to distribute light on the walls, so luminaires that distribute the light diffusely, like luminous "buttons" mounted to the ceiling, or luminous wall sconces, are reasonable options. (See luminaire schedule). Linear fluorescent lamps (2', 3', 4') will produce more lumens per watt than compact fluorescent lamps, but both may be used. Recessed wall washers, lighting artwork or graphics, are another solution. Light colored wall finishes (65%+) are recommended, since they will reflect more light, resulting in a brighter appearance for the same light output.



courtesy: The Lighting Research Center, RPI, Delta Publications

Luminaires should distribute light to the corridor walls.

### STAIRS

Fire stairs may be unfamiliar to the user, especially if only used in emergencies, so should be lighted in a simple, straightforward way. It is inadvisable to mount luminaires directly over the steps, because the luminaires will be difficult to maintain. The most common solution in stairwells is a wall-mounted fluorescent fixture mounted at each landing. The distribution should be wide enough that the illumination overlaps on the intermediate steps. The lighter colored the finishes are in a stairwell, the more the interreflections will spread the light. A luminaire that shields the direct view of the lamp is preferred, but in a white painted stairwell, even a bare lamp T8 may be acceptable, as long as vandalism is not a problem.

In more decorative stair or ramp applications, like public lobbies or theaters continuous luminaires (such as LED strips) running parallel to the steps, located under the nosing, can be very effective, but costly. Individual step lights are designed to be mounted on the adjacent wall, about 18" above the treads. At the very least, one should be located at the top and bottom tread. More, low output steplights on a regular pattern related to the treads are safer than just a few, very bright steplights. Lights mounted under handrails are another option, but caution should be used because these may be glary if the run of stairs extends above eye level, and they may provide more lumens or consume more watts than can be accommodated under the energy codes.

## ENERGY CONSERVING DESIGN STRATEGIES

### CORRIDORS AND STAIRS — SPECIFIC STRATEGIES FOR ENERGY CONSERVATION

- Use light-colored finishes to achieve more brightness and inter-reflections for the wattage consumed.
- Linear fluorescent lamps are a good choice for stairs. They are diffuse, easily controlled, and restrike instantly for emergency usage
- Use daylight when available so that electric lighting is not required during most hours of occupancy.
- Consider multiple level output ballasts connected to occupancy sensors in some luminaires in circulation areas where full darkness is not acceptable to owner or users.



courtesy: NYC Department of Design and Construction

Light-colored finishes improve the light distribution through inter-reflections.

### ENERGY CODES: WATTS / SQUARE FOOT BUDGETS

FUNCTION	ENERGY CONSERVATION CODE OF NEW YORK STATE		ANSI/ASHRAE/IESNA STD.90.1		NOTES
	2002	+/- 2007	1999 / 2001	2004	
Corridors	0.8	0.9	0.7	0.5	1
Corridors-Healthcare	0.8	0.9	1.6	1.0	1,2
Stairs	0.8	0.9	0.9	0.6	1,3

1. Multiply this value by the square footage of the dedicated workshop spaces. Sum the results of all the individual spaces in the building to determine the total building interior power allowance using the space-by-space method. The design of an individual space is not required to meet the watt/sf limits, as long as the total building connected load does not exceed the total interior power allowance. 2. NYS Energy Code does not differentiate between types of corridors. 3. NYS Energy Code does not list a separate category for stairs. Value comes from category of “Corridor, restroom and support area”

### LIGHTING CONTROLS

If circulation spaces are daylighted, a simple photosensor on-off or two-level switching strategy can be employed. (See the control technologies section.) In corridors or stairs that are actively used, i.e. are occupied at least once every twenty minutes throughout the workday, lighting controls should be designed to automatically shut off most or all lights after the spaces are no longer occupied. See nightlighting, below. For circulation spaces that are only intermittently used (service corridors) or rarely used (firestairs) there are methods of occupancy sensing controls that can save considerable energy over the life of the building. Ultra-sonic motion sensors designed for long corridor applications are readily available. In stairwells, these should be most sensitive to detecting the motion of the door opening. Since a broken occupancy sensor defaults to full on, this technology does not represent an emergency risk. Verify that any controls specified in stairwells have a fail-safe operation that meets all safety requirements for egress.



courtesy: The Lighting Research Center, RPI, Delta Publications

Locate luminaires above stair landings so they are accessible for maintenance.

Automatic on-off occupancy sensing is a simple choice and acceptable for many buildings where the occupants feel secure. The time delay should be set for about 30 minutes and the sensitivity set to “high”. In buildings involving multiple tenants or open to the general public, the occupants may not feel secure having the lights suddenly turn on a completely dark space. In such cases, a small percentage of lights (5%-10%) can remain on during extended hours of occupancy. These should be located adjacent to doors or other points of entry. If there are multiple points of entry, so that the number of lighted fixtures would be in the 20%-25% range, the fixtures closest to these doors can be fitted with two- or three-level ballasts, so that they operate at a lower level (33%-50%) when the space is unoccupied, then increase to full output when the space is occupied. All the remaining lights in the corridor can be turned from full off to full on from the same occupancy sensor.

It appears that New York City will allow stairwells to be controlled in the same way, with low output (33%) when unoccupied, then increase to full when the stairwell doors open or other motion is detected. Because the lowest light level keeps the cathodes warm, the lamp life is not reduced with frequent multiple-level switching. Some manufacturers provide luminaires with integral motion sensors and high-low ballasts, designed expressly for stair and corridor applications.

**Night lighting:** Only the minimum lights should operate all night after the building is empty. Provide night lighting at entries so that employees or emergency personnel can find local switches. Provide the minimal night lighting necessary for safety and security and use occupancy sensors for night lighting controls. Consider motion-activated recording devices and lights where un-monitored security cameras are used.

## OTHER CONSIDERATIONS

### DAMP LABEL

Use Damp labeled (DL) luminaires for corridors or stairs that are on the exterior of a building but protected by an overhang. Even if an interior stairwell leads to the exterior of a building, specifying DL fixtures is good practice.

### COMMISSIONING

Commissioning and calibration of lighting controls and emergency systems is necessary to ensure that equipment operates as intended. Equipment related to lighting any paths of egress should be re-commissioned annually.

### DIRT DEPRECIATION

Corridors and stairs may be classified as “very clean” to “dirty” depending on their location. Cleaning of light fixtures is recommended every two years in a clean environment, and annually a dirty one.

### EMERGENCY LIGHTING

In the event of an emergency, corridors and stairs are the primary means of egress in a building. Some or all of the lighting in egress corridors and stairs should be on an emergency circuit. If an emergency generator is not used, all lights on the emergency circuit must be fitted with battery packs or inverter ballasts. If emergency batteries are used, they need to be tested every two years.

### ELECTRICAL CODE ISSUES

The team must conform with New York City codes, ADA, and any other relevant requirements for life safety issues for corridors and stairs.

For reduced energy consumption, the following four-foot long fluorescent lamps are the DDC standard: 32 Watt T8, 3,100 lumen, CRI 85+, 3500 Kelvin, low mercury, extended life (24,000 – 30,000 hours). Note that DCAS (NYC Department of Citywide Services) will have available one of the following lamps: GE #F32T8 XL SPX35 HLEC (10326); Philips #F32T8/ADV/835/ALTO (13988-1); Osram/Sylvania #FO32/835/XPS/ECO (21697).

## SAMPLE LUMINAIRE SCHEDULE FOR CORRIDORS AND STAIRS

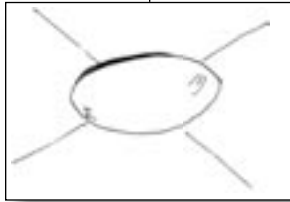

### SURFACE-MOUNTED OR SEMI-RECESSED BUTTON LIGHTS

**Location:** Corridor ceiling  
**Lamps:** (1) 26W or (2) 13W Twin Tube CFL, 830 – 835 color  
**Description:** Surface-mounted bowl with white opal glass or acrylic diffuser. Electronic ballast.

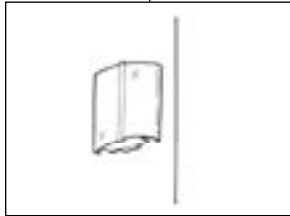

### ADA WALL SCONCE

**Location:** Corridor wall  
**Lamps:** (1) 26W quad, or (2) 18W Twin Tube CFL, 830 – 835 color  
**Description:** Decorative wall sconce with glowing front face. Extension from wall must be less than 4" or the bottom must be mounted at least 6'-8" above the floor for ADA compliance. Electronic ballast.

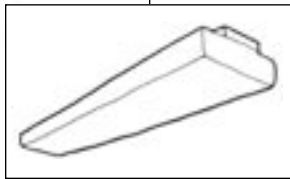

### FLUORESCENT WRAP-AROUND

**Location:** Stairwells: ceilings, walls or undersides of landings  
**Lamps:** (1) or (2) 28-32W, High Performance T8, 835 - 841 color  
**Description:** Surface-mounted. White baked enamel housing and prismatic lens. Multi-lamp ballasts. 66% minimum fixture efficiency. When used on wall, extension from wall must be less than 4" or the bottom must be mounted at least 6'-8" above the floor for ADA compliance.

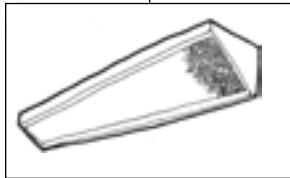

### FLUORESCENT TRIANGULAR WALL FIXTURE

**Location:** Stair walls  
**Lamps:** (1) or (2) 28-32W, High Performance T8, 835 – 841color  
**Description:** Surface-mounted. White baked enamel housing and prismatic lens on two sides. Electronic instant-start, multi-lamp ballasts.

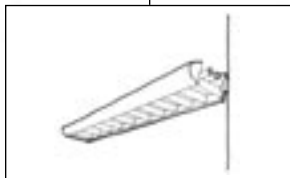

### FLUORESCENT WALL-MOUNTED FIXTURE DIRECT/INDIRECT

**Location:** Corridor  
**Lamps:** (1) or (2) 28-32W, High Performance T8, 835 – 841 color  
**Description:** Surface-mounted fluorescent luminaire in lengths of 4' or 8'. White baked enamel housing and white or semi-specular louver. Electronic parallel instant-start, multi-lamp ballasts.

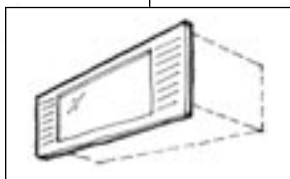

### RECESSED STEP LIGHTS

**Location:** Stairs, ramps, corridors  
**Lamps:** (1) 18W, 1200 lumens 835 – 841 color  
**Description:** Compact fluorescent step light. Wall-recessed, prismatic lens or louver. 120v integral ballast. Mount a minimum of 12" above the step, 18" preferred.



### LED EXIT SIGNS

**Location:** Corridors, Stairs, Rooms  
**Lamps:** Red LEDs  
**Description:** Surface-mounted, edge-lit or back-lit LED exit sign. Letters must be red and a minimum of 8" high in NYC.

## TOILETS, LOCKERS AND SHOWER DESIGN BRIEF

The NYC Department of Design and Construction (DDC) manages the construction and renovation of NYC's municipal buildings, many of which contain public restrooms as well as toilets, lockers and shower facilities for their employees. These guidelines are intended for municipal buildings such as offices, libraries, institutions and light industrial buildings. Although many considerations may apply, these guidelines were not developed for spaces subject to vandalism, requiring high security, or for commercial spas and sports centers.

### LIGHTING QUALITY STRATEGIES

Toilet rooms, locker rooms and showers have specific considerations because of their function and spatial characteristics. Please review and use the guidelines below, in concert with the basic design and quality issues discussed earlier in the Design Strategies section of this manual.

### SPECIFIC LIGHTING QUALITY AND QUANTITY STRATEGIES

ISSUE	IMPORTANCE
Relationship between light source and visual task and viewer	Very Important
Glare Control – Direct and Reflected Glare	Important
Three-dimensional modeling of objects	Important
Uniformity – No Shadows	Somewhat Important
Luminances of Room Surfaces	Somewhat Important

From The IESNA Lighting Handbook, 9<sup>th</sup> Edition.

courtesy: NYC Department of Design and Construction



Lighting is primarily needed at the perimeter walls of restrooms -- over mirrors, sinks and toilets.

#### Relationship Between Light Source And Visual Task And Viewer

The relationship of the light source to the objects in the space (toilets, lockers, mirrors) and the reflection of light from these surfaces to the viewer is very important in these space types, to avoid veiling reflections, shadows and glary lamp images. (See layout strategies)

#### Glare Control

The most common glare problems in toilet, locker and shower lighting are from direct reflections of light sources in mirrors, or from veiling reflections on glossy or shiny surfaces that mask visibility.

#### Three-dimensional Modeling

Lighting that promotes facial recognition and modeling is preferred in spaces where regarding mirrored images is a primary task. A combination of light from the front and sides accomplishes this.

#### Uniformity

A wide range of brightness contrast, up to a 20:1 ratio, may be acceptable in these types of spaces, as long as the lights are located appropriately in relation to the task and the viewer. Light-colored finishes reduce contrast and shadows.

#### Reflectances and Finishes

To reduce the contrast, promote inter-reflections, and utilize the light, walls and ceilings should be white or very light in color, with a minimum reflectance of 80%. Toilet partitions should be no darker than 50% reflective. Mirrored area should be kept to a minimum, and preferably not extend above 6'-6" AFF.

## Color

In order to limit the number of lamp types on a project, the lamps used in restrooms, locker rooms and showers should be the same as used elsewhere. Otherwise, high color rendering (CRI 80+) and color temperatures between 3000 and 3500 Kelvin are appropriate for these space functions.

## Daylighting

While daylight is not required in these spaces, it is desirable and reduces the need for safety lighting during daylight hours. If spaces are located along building perimeter, consider providing windows at the transom level with light shelves to reflect light deep into space. Obscuring glass that provides privacy for the occupants also controls solar heat gain.

## LIGHT LEVELS RECOMMENDED AVERAGE MAINTAINED ILLUMINANCE, IN FOOTCANDLES (FC)

FUNCTION	HORIZONTAL FC	VERTICAL FC	NOTES
Toilets and washrooms	5-10	3	
Locker rooms	10	3	
Shower rooms	5-10	3	1

From the IESNA Lighting Handbook, 9th Edition.

1 No value for showers given by the IESNA.

## DESIGN AND LAYOUT STRATEGIES

### PUBLIC AND EMPLOYEE RESTROOMS

**Over toilets:** Lights placed on the wall or in the ceiling behind the toilet provide light from the best angle for cleaning and for assessing the cleanliness of the plumbing fixtures. For larger ADA stalls or single toilet rooms, a secondary ceiling or mirror light may be required.

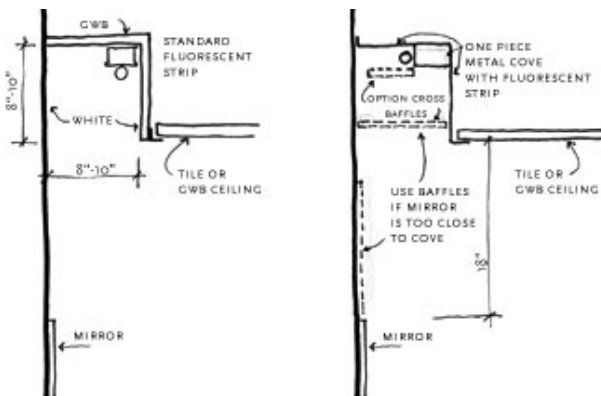

For lighting sinks and mirrors, the light should come from above and the side for best facial modeling. Continuous fixtures near the junction of the wall and ceiling provide acceptable distribution.

A standard solution for both toilet and mirrors in restrooms is the use of a continuous slot at the corner of the wall and ceiling, recessed 8" to 10" above the ceiling line. This

can be constructed out of building materials with an industrial fluorescent strip at the top (above, left). Slot luminaires are also available (above, right) that mount to the upper wall on one edge, and create a continuous angle on the opposite edge to support suspended ceiling tiles. This solution is effective only if the wall is white or very light in color, and acts as a reflective surface to disburse the light. These walls should be egg-shell or semi-gloss in finish, and not specular (shiny). Consequently, the use of mirrors should be limited, and the top of the mirror should stop at least 18" below the lower ceiling line. If a mirror extends closer to the lighting slot, baffles or louvers will be required to shield the reflections of the lamps in the mirror. The addition of baffles combined with the reduction of diffuse wall reflection will degrade the effectiveness and the efficiency of the slot, requiring more energy to achieve the desired effect.

Additional lensed or baffled downlights may be required for areas that are more than 15' away from either mirror or toilet lights (right).

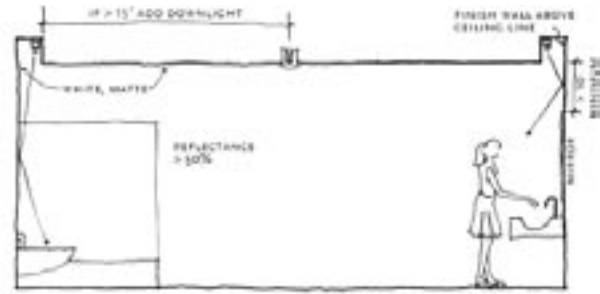

## LOCKER ROOMS

In locker rooms, the lockers generally replace the wall as the dominant vertical surface, so it is extremely important that the interior and exterior finishes of the lockers be light in color (70% or higher reflectance) and eggshell or semi-gloss in finish.

The most difficult task in a locker room is seeing into shadowy lockers. Visibility is further blocked by partially opened locker doors and the user.

The most effective lighting is diffuse light that is distributed to the vertical surfaces. Luminaires with high-transmission wrap-around lenses or radical-louvered lights running parallel to the aisles effectively light into the lockers. (See Luminaire Schedule). Open-celled luminaires or downlights distribute most of their light directly down on the horizontal surfaces and may create harsh shadows in the lockers.

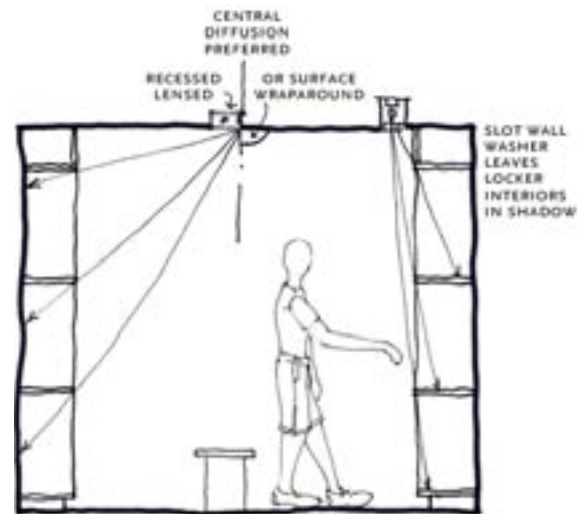

As in restrooms, the use of specular surfaces and mirrors should be limited because those finishes do not reflect light in the diffuse distribution desired. Indirect lighting is a more attractive way to provide diffuse light on vertical surfaces, and is often used in commercial facilities such as spas, health clubs or hotel fitness centers. It should be noted, however, that almost twice as much energy is consumed by bouncing the light off the ceiling before reaching the lockers. A continuous wall slot at the face of the lockers (above) will graze off the fronts, but not adequately light inside of the locker.

If a sleeping or rest area is associated with the locker room, care should be taken to supply a separate, local switch for lights in that area, and red-colored night lights. An architectural valance or curtain should shield luminaires or bright surfaces in the adjacent locker room from the view of resting occupants.

## SHOWER ROOMS

Small shower rooms may be lighted with fixtures inside the stall, specifically rated for showers and spas. More commonly, however, showers are lighted from damp-location rated (DL) lighting fixtures located in the adjacent circulation areas (right). These fixtures should be fitted with a diffuser that distributes the light widely as well as protects the bare lamps from splashes. Light fixtures surface-mounted to the ceiling are effective at distributing the light over shower doors or curtains, but recessed lensed lighting fixtures are also acceptable. Light-colored or translucent curtains or shower doors are essential for transmitting the light into the stalls.

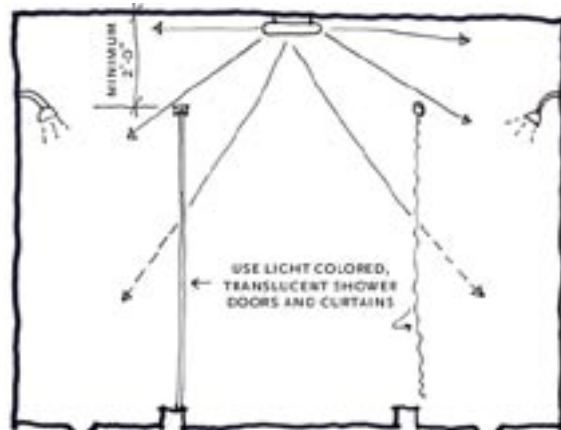



## ENERGY CONSERVING DESIGN STRATEGIES

- Light colored finishes
- Optimal location of luminaires to task and occupant
- Lighting controls.

### ENERGY CODES: WATTS / SQUARE FOOT BUDGETS

FUNCTION	NYS ENERGY CODE		ASHRAE/IESNA STD.90.1		NOTES
	2002	+/- 2007	1999/2001	2004	
Toilets and washrooms	0.8	0.9	1.0	0.9	1,2
Locker rooms	0.8	0.9	0.8	0.6	1,2
Shower rooms	0.8	0.9	1.0	0.9	1,2,3

1. Multiply this value by the square footage of the dedicated workshop spaces. Sum the results of all the individual spaces in the building to determine the total building interior power allowance using the space-by-space method. The design of an individual space is not required to meet the watt/sf limits, as long as the total building connected load does not exceed the total interior power allowance. 2. From NYS Energy Code category of “Corridor, restroom and support area” 3. No values are given for showers in Std. 90.1. Same values as toilets and washrooms assumed by authors, due to partitions.

### LIGHTING CONTROLS

Due to a sense of vulnerability in toilets, locker rooms and showers, the light controls should be carefully designed to maintain a sense of security. Automatic on-off occupancy sensors are a good solution, but should never turn off all the lights. Except in daylighted spaces, at least 20% of the lights in toilets, locker rooms and showers should be zoned separately to remain on throughout the hours of building occupancy. A time or sweep-off control system can turn off these “orientation” lights at the end of the occupied period. The orientation lights should be strategically located, so in case a “false-off” is caused by the occupancy sensor, occupants will not be frightened by complete darkness during the short time before their motion reactivates the lights. Ultrasonic-type occupancy sensors are the most effective in these spaces blocked by toilet partitions, shower doors and high lockers, since they don’t require line-of-sight to operate. Sensors should be located frequently to compensate for the vertical obstructions. Occupancy sensors designed for a linear or “corridor” distribution may be a good choice for the aisles of elongated locker rooms.

### OTHER CONSIDERATIONS

#### DAMP LABEL, WET LABEL

Damp-Labeled (DL) luminaires are not required for restrooms and locker rooms, but it is good practice to specify DL fixtures for these spaces, especially if they are adjacent to a shower, sauna, steam room, pool or similar environment. Damp-Label must be specified in shower rooms. Use Wet-Labeled (WL) lighting fixtures in environments with high humidity or strong chemicals. Use luminaires specifically rated for saunas, steam rooms and inside shower/tub stalls as required.

#### DIRT DEPRECIATION

These spaces types are classified as “very clean”, but the higher humidity may result in a greater percentage of airborne particulates deposited on the lamps and diffusing lenses. Cleaning of light fixtures and lamps is recommended every two years.

## EMERGENCY LIGHTING

Since occupants may be wet or partially clothed when a loss of power occurs, a greater degree of emergency lighting coverage than required by code is recommended for showers and locker rooms. Closer spacing of emergency luminaires will provide a more uniform distribution. Also, the view of exits and paths of egress should not be blocked by vertical obstructions.

## ELECTRICAL CODE ISSUES

- Use ground fault circuit interrupter (GFCI) or arc fault circuit interrupter (AFCI) circuit breakers for receptacles where required.
- Use luminaires rated for correct application, like wet location, spas or saunas.

For reduced energy consumption, the following four-foot long fluorescent lamps are the DDC standard: 32 Watt T8, 3,100 lumen, CRI 85+, 3500 Kelvin, low mercury, extended life (24,000 – 30,000 hours). Note that DCAS (NYC Department of Citywide Services) will have available one of the following lamps: GE #F32T8 XL SPX35 HLEC (10326); Philips #F32T8/ADV/835/ALTO (13988-1); Osram/Sylvania #FO32/835/XPS/ECO (21697).

## SAMPLE LUMINAIRE SCHEDULE FOR TOILETS, LOCKERS & SHOWERS

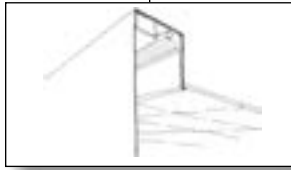
	<p><b>RECESSED TOILET WALL SLOT WITH BAFFLE</b></p> <p><b>Location:</b> Toilet room ceiling near mirror  <b>Lamps:</b> (1) 28-32W, High Performance T8, 830 – 835 color  <b>Description:</b> Recessed fluorescent 10" in depth by 4' lengths as needed to complete wall length, regressed cross baffles. Tandem wire and use two-lamp ballasts where possible. 52% minimum fixture efficiency.</p>
	<p><b>RECESSED TOILET WALL SLOT REFLECTOR</b></p> <p><b>Location:</b> Toilet room ceiling perimeter or mirror  <b>Lamps:</b> (1) 28-32W, High Performance T8, 830 – 835 color  <b>Description:</b> Recessed fluorescent 10" in depth by 4' lengths as needed to complete wall length, semi-specular wall washing reflector. Available with or without cross baffles. Damp location rated. Tandem wire and use two-lamp ballasts where possible. Minimum 62% fixture efficiency.</p>
	<p><b>TOILET FLUORESCENT STRIP</b></p> <p><b>Location:</b> Toilet room ceiling  <b>Lamps:</b> (1) or (2), 28-32W, High Performance T8, 830 – 835 color  <b>Description:</b> Surface-mounted 4' white baked enamel fluorescent strip. Minimum 85% fixture efficiency.</p>
	<p><b>RECESSED LENSED FIXTURE</b></p> <p><b>Location:</b> Shower aisles or locker rooms  <b>Lamps:</b> (2), 28-32W, High Performance T8, 830 – 835 color  <b>Description:</b> White upper reflector and prismatic lens. Damp location rated. Electronic instant-start, multi-lamp ballasts. Minimum 65% fixture efficiency.</p>
	<p><b>WRAP-AROUND FLUORESCENT</b></p> <p><b>Location:</b> shower aisles or locker rooms  <b>Lamps:</b> (1) or (2) 28-32W High Performance T8, 830-835 color  <b>Description:</b> Surface-mounted fluorescent luminaire with acrylic wrap-around diffuser or lens. Damp location rated. Electronic instant-start multi-lamp ballasts. Minimum 60% fixture efficiency.</p>
	<p><b>RADIAL LOUVER FLUORESCENT STRIP</b></p> <p><b>Location:</b> Locker room  <b>Lamps:</b> (1) 28-32W, High Performance T8, 830 – 835 color  <b>Description:</b> Surface or stem-mounted fluorescent luminaire in lengths of 8'-0" or 12'-0". White baked enamel finish. Minimum 90% downlight. Minimum 62% fixture efficiency. Cross baffles 1-3/4" deep x 2" on center. White painted cross baffles. Total 2-lamps per 8' long fixture. Two-lamp electronic instant-start ballast, nominal 55 input watts. Also available in 12' lengths and continuous rows.</p>
	<p><b>BUTTON LIGHTS</b></p> <p><b>Location:</b> Shower aisles or locker room  <b>Lamps:</b> (2) 13W CFL, 830 – 835 color  <b>Description:</b> Surface-mounted bowl with white opal glass or acrylic diffuser. Damp location rated. Two-lamp electronic ballast. Minimum 51% fixture efficiency.</p>
	<p><b>SHOWER RATED LIGHT</b></p> <p><b>Location:</b> Shower ceiling  <b>Lamps:</b> (1) 32W CFL, 830 – 835 color  <b>Description:</b> Semi-recessed, wet location rated, compact fluorescent downlight with dropped lens. Integral 120v ballast. Mount a minimum of 8'-0" above the shower rim. Minimum 36% fixture efficiency.</p>

# BUILDING EXTERIOR LIGHTING DESIGN BRIEF

The NYC Department of Design and Construction (DDC) manages the construction and renovation of NYC's building stock throughout the five boroughs. These guidelines apply to the exterior areas of these facilities immediately adjacent to the buildings, including entry and egress lighting, exterior security lighting, parking lots, and sidewalks.

## SPECIAL EXTERIOR LIGHTING QUALITY ISSUES

During the day, the exterior environment is flooded with ambient light from the sun and sky. Not only are light levels high, but the distribution of natural light is somewhat uniform. The nighttime environment is completely different, with a dark sky vault and lots of local man-made light sources. High contrast and the potential for glare is much higher at night, so the strategies of exterior lighting can be quite different than those used in building interiors. In addition to the general qualitative issues described earlier in this manual, the following issues have particular relevance to the lighting of building exteriors:

- Nighttime visibility, peripheral detection, adaptation
- Glare control
- Light Pollution and Light Trespass
- Security, safety, shadows, facial recognition, uniformity
- Orientation, way-finding, points of interest
- Color appearance and contrast
- Reflectances and surface characteristics
- Daytime appearance of exterior luminaires



courtesy: Lighting Research Center, RPI, Delta Publications

Close spacing of low-output luminaires reduces glare and provides comfortable lighting for faces.

### Nighttime Visibility

The eye is capable of adapting to a wide range of light levels but not at the same time. To function well, it must be adapted to the prevailing light conditions. During daytime conditions, our eyes use “photopic vision,” which utilizes the eye’s cones and the center of the visual field. The eye works differently when it is adapted to low light levels. Under very dark, moonlit conditions, our eyes use “scotopic vision,” which primarily utilizes the eye’s rods, resulting in greater acuity in the peripheral visual field. In most urban and suburban environments like New York City, our eyes use “mesopic vision,” which is a combination of both photopic and scotopic. In nighttime environments, the goal of the lighting design is to keep the eye adapted to mesopic or scotopic vision, and not to introduce high light levels that will cause an imbalance in the visual field and cause the eye to try to use photopic vision. (See glare and security concerns below). Recent research indicates that light sources that are rich in blue and green (metal halide or fluorescent) improve peripheral mesopic vision, clarity and depth of field better than sources rich in red and yellow, such as incandescent and high pressure sodium.

### Glare Control

Glare is caused by high contrast between the glare source and the prevailing light conditions to which the eye is adapted. Consequently, the same headlights that feel blinding on a dark road are only uncomfortable on a well-lighted urban street, and do not cause glare at all during the day. There are several ways to reduce contrast and the potential for glare in the nighttime environment:

- Distribute light more uniformly, and over a broader area. Reduce the ratio of surface brightness between the lightest and darkest surface.
- Reduce light levels
- Reduce source brightness. Use more fixtures with a lower wattage per fixture.
- Shield light sources.

Contrast ratios should be close to uniform, in the 1:5 ratio between average and maximum luminance. Exterior lights should be shielded and located to avoid glare. Fixtures near the property line should have “house-side shielding” to prevent glare to residential neighbors.

### Light Pollution

The orange sky glow above the New York metropolitan area is a result of light pollution. Stray light that goes directly into the atmosphere wastes energy and can be disruptive to humans and wildlife. The LEED™ rating system offers a credit for minimizing light pollution by requiring full cutoff luminaires (i.e., where no light exits the fixture above the horizontal). LEED™ also restricts façade lighting and building lighting from leaving the site when lighting façades choose fixtures with a controlled distribution rather than a wide or diffuse distribution. In applications where lighting up from below may be the only alternative (like statues and monuments), light specific surfaces rather than spilling over with a blanket of light. It should be noted that not all luminaire light pollution is caused by light emitted above the horizontal. On average, light reflected off the ground can account for up to 20% of light pollution. Hence, a luminaire with a very narrow distribution directly down may cause more reflected light pollution than a luminaire with a wider distribution, where the reflected light at low angles is more likely to be absorbed by obstructions.



photo: ©2003, Todd Carlson

Light pollution (right) obliterates the view of the stars.

### Light Trespass on Neighbors

Luminaires mounted to buildings and on poles should be aimed or shielded to avoid any light trespass into the property or windows of adjacent buildings, especially in residential areas. Unshielded security floodlights or “wall-packs” should be avoided. Nighttime lighting can have a negative effect on human sleep cycles. The international lighting authority, the Commission Internationale de l’Eclairage (CIE) has developed recommendations for establishing community standards for limiting light trespass, in recognition that cities have different lighting needs than outlying areas. These recommendations are shown in the chart below. While these have not yet been adopted in New York City, verify if there are any local ordinances that may be more stringent, or in rare cases may require higher light levels, such as Times Square.



Avoid “wall-pack” type of luminaires (above) with no glare shielding.

### ENVIRONMENTAL ZONES FOR LIGHT TRESPASS

ZONE	DESCRIPTION FROM THE COMMISSION INTERNATIONALE DE L’ECLAIRAGE (CIE)	PRE-CURFEW LIMIT**	POST CURFEW LIMIT**
Zone E1	Areas with intrinsically dark landscapes. E.g. National Parks, self-limited residential communities.	0.1 fc	0.1 fc
Zone E2	Areas of low ambient brightness. Outer urban and rural residential.	0.3 fc	0.1 fc
Zone E3	Areas of medium ambient brightness. Urban residential areas.	0.8 fc	0.2 fc
Zone E4	Areas of high ambient brightness. Urban areas with both residential and commercial use, and experiencing high levels of nighttime activity.	1.5 fc	0.6 fc

Chart adapted from IESNA-RP-33-99. \*Light levels are measured at the perimeter of a site, i.e., at the neighbor’s eye in the vertical plane perpendicular to the line-of-sight. “Curfew” time is established by the community or the design team.

**Setting Priorities:** Some of the requirements for nighttime lighting conflict with other project requirements. For example, the desire for security, comfortable face lighting and wide distribution of light may seem to conflict with the tighter beam control recommended to avoid light pollution or light trespass. Work together as a team to develop compromise solutions (e.g., near-horizontal distribution luminaires but not above horizontal). If a good compromise cannot be accomplished, set team priorities (e.g., security concerns will outweigh sky pollution concerns for a specific jail perimeter wall).

### Security – Safety, Shadows, Facial Recognition, Uniformity

Lighting that provides a sense of security increases legitimate nighttime activity, which in turn increases actual security. This is accomplished by:

- Increased uniformity
- Reduced shadows
- Reduced source glare
- Avoid over-lighting
- Natural appearance of people and surrounding objects.
- Natural color

Excessively high light levels or high wattage visible sources should be avoided, because they can cause the eye to lose its nighttime adaptation level, making it more difficult to see into shadows or detect peripheral motion. Sidewalks, pathways and bikeways should be designed to provide illumination on the vertical plane, so people's faces are comfortably lighted and they can identify the faces of others at a reasonable distance. Since low height bollard luminaires light the ground and do not contribute to face lighting, they should only be used in conjunction with other, taller luminaires, or where another criterion (such as the view of water) takes precedence. Plantings or obstructions that may create deep shadowy areas should be redesigned or coordinated with supplemental lighting. Additional transitional lighting should be provided to the sides of walkways as they pass marginally secure areas, such as building alcoves, below-grade building entrances, or dense shrubbery. Where guards or security cameras are in fixed locations, the lighting should be directed away from the viewers, to increase visibility.

Lighting to promote safety from tripping or other hazards is enhanced by the same factors as security lighting. In addition, light fixtures should be located at changes in grade level or surface material, at pathway intersections, or near any dangers such as pools or walls.

### Orientation – Way-finding & Points of interest

Because there is so little ambient light at night, whatever is illuminated gains importance in the visual environment. Careful establishment of a design hierarchy can create an organized composition that is safe, attractive, and orienting to the observer. Good quality lighting can add to a positive urban image, and establish the relative importance and character of buildings, landmarks and landscape elements. Conversely, poorly planned lighting can confuse the viewer, give misleading visual clues, and reduce the sense of security and safety of a building or neighborhood. It is generally a good approach to light buildings and landmarks in a natural manner, so that an area is equally recognizable day and night. Use buildings and monuments as reference points to enhance nighttime orientation. Light pathways uniformly or, if this is not possible, consistently place lights at important destinations or nodes of travel.



Regular spacing of post lanterns creates an organized rhythm for walkways.

photo: Robert Prouse

### Surface Characteristics – Reflectances and Finishes

Polished, glossy, and shiny surfaces should be avoided, because specular reflections can reduce visibility day and night. The most matte finish available that will provide acceptable maintenance should be used. Use low gloss or eggshell paints or anti-graffiti coatings. Use heavily brushed metal surfaces. Lighter colored materials should be used for steps and level changes, and to delineate paths from surrounding dark

vegetation. Concrete reflects more light than asphalt and makes a road or parking lot or path feel brighter at low light levels. However, the lighter path and roadway finishes that improve luminance ratios also cause more light to be reflected upward to cause sky glow.

## Color

Lamps in the bluer range with reasonably good color rendering (above 65 CRI) are preferable for nighttime visual acuity. It is believed that the better visibility resulting from a cooler CCT and higher CRI can offset a lower lumen output. Consequently, lamps such as metal halide with pulse-start ballasts, fluorescent amalgam, induction sources, and white LEDs or red-green-blue arrays of LEDs can be effective at night. Standard high-pressure sodium (HPS) lamps are adequate for highway driving but do not have adequate color rendering for most exterior applications. “White” HPS lamps provide better color rendering although the efficacy is below that of metal halide. Use ceramic metal halide for superior color rendering (CRI 75+) in heavily populated pedestrian locations. The apparent color (correlated color temperature) should range from 3200K to 5000K, depending on the context. The warmer (3200K) color temperature lamps may provide a better balance with adjacent city street lights using the yellow HPS lamps maintained by NYC Department of Transportation. An international design competition was held in 2004 to design the NYC streetlights of the future. The City Lights competition was co-sponsored by the NYC DDC and the NYC Department of Transportation (DOT). The new streetlight designs will eventually be added to the DOT Street Lighting Catalogue and will provide alternatives for lighting streets, sidewalks and parks. The winning design utilized LED sources, in addition to the required high pressure sodium option. While the lumens/watt of LED sources is currently much lower than metal halide or high pressure sodium, it is expected to increase in the future. Mock-ups and working prototypes over the next few years will determine the viability of the LED sources for this application.

## Biological Effects of Color Spectrum

Lighting levels should be reduced in the evenings and nighttime to enable residential occupants to have a normal sleep cycle. The shorter blue wavelengths that are preferred for nighttime visibility are also more disruptive to sleep patterns. Consequently, site lighting near residences should always be controlled with “house-side shielding” or otherwise directed away from bedroom windows.

## Daytime Appearance of Exterior Luminaires

Thought should be given to the appearance of exterior luminaires in the daytime environment. The color of poles, details of bases, spacing and coordination with street furniture all have an impact on the character and scale of a property. For larger projects with multiple types of light fixtures, consider organizing the appearance into a “family” with similar visible features, and an appropriate combination of lamp colors. As



courtesy: The RETEC Group

Select a “family” appearance for luminaires and poles.

an alternative approach, simple poles in neutral, pale colors or fixtures mounted high on buildings can be used in a concealed manner to provide the primary illumination, while smaller, more decorative poles or fixtures can appear to be the “apparent source”. Concealed or primary luminaires should be accessible for maintenance, on the roof or at balconies or setbacks, and the beam pattern selected to avoid light trespass. Shielding should be used as required to avoid casting unwanted light patterns on the building itself. This technique of low wattage “apparent sources” supplemented by concealed, energy-efficient primary sources can save both energy and equipment cost, if done properly.

## SPECIAL EXTERIOR LIGHTING TECHNICAL ISSUES

### CONTROLS

At a minimum, control exterior lighting so that it is not operating during times of sufficient daylight, through the use of astronomical time switches and/or photosensor override. Consider limiting the nighttime hours that the exterior lighting operates. Only the few fixtures necessary for safety or security should operate all night. Occupancy sensors are rarely an acceptable choice for security because they are problematic with the metal halide sources most often recommended for exterior applications, since the lamps may not re-strike in an acceptable timeframe. In addition, repetitive switching may degrade lamp life, and will be an irritant to the neighbors.

### EXTERIOR SECURITY LIGHTING

Diligence should be taken in the design of a security lighting system when exterior lights would normally be turned off for part of the night. Take into consideration whether the camera feed is under constant and instantaneous surveillance, or whether it is intended to provide a record of security breaches after the event. It is also important to avoid glare to pedestrians and motorists, and to avoid light trespass to neighbors.



photo: Hayden McKay

Avoid glary entry lighting like the above.

While security cameras can operate under extremely low light levels (less than .01 FC) HID light sources are not commonly dimmed. Consider some of the following strategies to avoid unnecessary energy consumption, light trespass and light pollution:

- Specify separate fixtures exclusively used to provide the low light levels for security cameras.
- Aim the surveillance cameras at specific points of entry to the building, where ordinary lighting is placed, rather at broad areas on the site.
- Avoid aiming lights at high angles or beyond the site boundaries.
- Use multiple-level HID ballasts controlled by timeclock to operate after hours at their lowest light level for security cameras. Multiple-level ballasts may also be activated by motion sensors, so that they change from the lowest to the highest setting when activity is sensed.

### WET AND DAMP LOCATIONS LUMINAIRES

Luminaires that will be exposed to the environment in unprotected locations, or installed in masonry, concrete slabs, or in direct contact with the earth, require a “wet location rated” label. Exterior luminaires that are somewhat protected from weather, such as those recessed under overhangs, should be supplied with a “damp location rated” label indicating that their design and materials resist galvanic action and corrosion. Non-metallic composite materials prevent corrosion but may not be as structurally suitable for some applications. Specify sealed and gasketed luminaires to prevent the intrusion of water and bugs, and to keep the luminaire cleaner. Weep holes should be appropriately located for the specific aiming angle of the luminaire.

### DURABLE, VANDAL-RESISTANT LUMINAIRES

Vandalism must be considered for lighting equipment placed in exterior public places in New York City. Most luminaires suitable for exterior weather are already more sturdy than interior luminaires, but may not stand up to vandalism. Consider the following:

- Sturdy construction to prevent destruction or disabling of the lighting.
- Tamperproof construction, mounting and access hardware, to avoid access to electricity or parts.
- Rigid and fixed aiming to prevent the luminaire from being turned in a direction other than intended. This is typically accomplished with a mechanical locking mechanism.
- Lenses or diffusers that resist breakage, weakening, or discoloration by aging or exposure to ultraviolet light.



## FULL CUTOFF LUMINAIRES

For the purposes of LEED™ (Version 2.1) light pollution credit, a “full cutoff” luminaire restricts the light output to only those angles below the horizontal to avoid light pollution to the night sky. The IESNA defines full cutoff as “a luminaire light distribution where zero candela intensity occurs at an angle of 90 degrees above nadir [straight down] or at all greater angles from nadir. Additionally, the candela per 1000 lamp lumens does not numerically exceed 100 (10 percent) at a vertical angle of 80 degrees above nadir. This applies to all lateral angles around the luminaire.” Light that is emitted closer to the horizontal (e.g., 50° - 80°) is valuable for lighting faces and improving the uniformity of light between luminaires. However, if light trespass is the greatest concern, luminaires that emit little or no light near the horizontal are preferable.

## DIRT DEPRECIATION

Since light output is significantly reduced by dirt and debris in fixtures, outdoor fixtures should be sealed and gasketed. A maintenance program should be established so that all luminaires are checked regularly, burnouts replaced, and those fixtures cleaned and resealed that show evidence of moisture or dirt. Indirect “burial” fixtures are discouraged because they are easily covered with grass, leaves, mud and other debris, resulting in a waste of energy. In addition, they contribute to light pollution because they distribute light upward to the night sky.



photo: Hayden McKay

Burial light require regular cleaning to maintain light output.

## THERMAL CONSIDERATIONS

Excessive surface heat can result from the tight seals necessary to weatherproof exterior fixtures. Take special care of this issue when specifying fixtures within reach of the building occupants or the public. UL testing protects against overheating and electrical failure, but does not address surface temperature that may be injurious to the public. Uplight “burial” fixtures are further insulated by dirt, so that all the heat must leave through the glass top. The excessive heat of these fixtures has been known to melt shoes, ignite mulch and burn children. The classification of “walk-over” only indicates that the fixture is capable of absorbing the weight of foot traffic - it does not mean that the temperature is safe for public walkways. Manufacturers are now producing burial uplights with lower temperatures on the upper glass surface.

## EMERGENCY LIGHTING

Two separate light sources should be provided on the emergency system at each means of egress to account for the possible burnout or ballast failure of one of the sources. This can be accomplished with two lamps in one fixture, or two separate fixtures. If the facility does not have an emergency backup generator, it will be necessary to specify fixtures with battery backup for essential safety, security or exiting requirements. The design of the emergency lighting plan should always seek to orient the public by providing a clear, organized path to safety with a minimum of glare. If high intensity discharge (HID) lamps such as metal halide or high pressure sodium are part of the emergency system, some accommodation must be made to avoid underlighting due to a slow warm-up or re-strike delay. This is typically handled by auxillary quartz-halogen lamps that provide emergency light instantly, then turn off when the HID lamp is fully lighted.



“Walk-over” does not mean a burial luminaire is thermally suitable.

## SPECIAL COMMISSIONING CONSIDERATIONS

Adjustable or aimable exterior lighting fixtures require nighttime adjustment. Requirements for contractor participation and special equipment (bucket trucks, walkie talkies) should be included in the specifications. See sample specifications on the DDC website.

## SPECIAL MAINTENANCE AND OPERATIONAL ISSUES

At night, without the ambient daylight, a broken fixture or burned-out lamp can create a significant zone of darkness and loss of uniformity. A much higher standard of maintenance is required for exterior luminaires since there is less overlap or interreflections found in building interiors. The maintenance schedule is usually driven by the security concerns. Outside maintenance contractors are available for frequent evaluation of exterior burn-outs, and can be contracted to replace essential security lamps within 24 hours. Planned group relamping, based on the predictable hours of operation, saves labor costs, reduces the need for emergency response, and limits unsafe conditions caused by lamp burn-outs.

## GROUND FAULT CIRCUITS INTERRUPTER (GFCI)

Exterior lighting should be connected to GFCI circuits. Consider low-voltage (12 volt or less) for underwater lighting and exterior applications that are easily accessible by the public.

## EXTERIOR ILLUMINANCE AND LUMINANCE RATIO RECOMMENDATIONS

SPACE TYPE CATEGORIES	HORIZONTAL FC (MINIMUM AVERAGE)	VERTICAL FC (AVERAGE)	LUMINANCE RATIOS	NOTES
Exterior building entries	5	3		1
Exterior doors, inactive	3	3		1
Exterior emergency paths of egress	1			1
Sidewalks and bikeways, roadside	2	1	4:1	3,4,6,A
Sidewalks, walkways, pathways, and bikeways, not roadside. High or medium conflict with cars.	0.5 to 1	0.2 to 0.5	4:1	3,4,A
Sidewalks, walkways, pathways, bikeways, not roadside. Low conflict with cars (NYC Residential)	0.4	0.1	4:1	3,4,A
Parking Lots – commercial / residential	0.2	0.1	20:1	2,4, 5, B
Parking lots – police, jails, enhanced security	0.5	0.25	15:1	2,4, 5, B
Loading docks, active / inactive	10 / 1	3 / .3		1
Storage Yards, active / inactive	10 / 1	3 / .3		1

1) From The IESNA Lighting Handbook 9th Edition, Chapter 10. 2) From The IESNA Lighting Handbook. 9th Edition, Chapter 22. 3) From IESNA RP-08-00. 4) Vertical illuminance is measured at 5' above grade. 5) Values shown are minimums, not average. 6) "Roadside" means mixed vehicle and pedestrian, or immediately adjacent to vehicular traffic, without barriers or separation. A) Luminance ratios average to minimum. B) Luminance ratios maximum to minimum.

## SPACE-TYPE GUIDELINES

### BUILDING ENTRIES

There is a wide range of appropriate solutions for lighting entries at night. The objective is to provide vertical illumination to comfortably light people's faces, and horizontal illumination to light the pathway and any changes in level. Small wall sconces often create too much glare to be effective. Enlarging the surface area of the sconce, without increasing the wattage, can lower the surface brightness to a comfortable level. A pool of light from a mounting position high on the building can provide a low level of horizontal ambient light to supplement the face lighting, or pedestrian scaled post lanterns can be used near the entry. If there is a canopy, indirectly lighting its white underside can provide both horizontal and vertical illumination, or other "layers" of light can be added to the composition such as wall-sconces or low brightness downlights. The location of security cameras should be taken into consideration so they can be shielded from direct light.



Lighting at entry should provide a gentle transition between outside and inside.

### CONTROLS

Use astronomical time switches or photocell overrides to ensure that lights do not operate when daylight is sufficient. Schedule lighting and zone exterior luminaires so that they are all on only when the building is occupied, with only a few lights remaining on for all night security. In rare cases, where entry doors are under buildings or deep overhangs, it may be necessary to use electric lighting during the day, to compensate for sky glare or to ease the transition from bright exterior to dark interior. In such cases, circuit the lights so that lower levels are provided for the nighttime conditions. The same concept applies to other areas with sudden and extreme light level transitions, such as garage entries, underpasses or tunnels. The surfaces of such transition areas should be finished with the lightest colors possible, i.e., a minimum wall and ceiling reflectance of 80% and a minimum ground reflectance of 40%.

### EMERGENCY EGRESS DOORS

For safe egress, provide lighting on the outside of the door threshold extending for a distance at least equal to the width of the door opening. At least two lamps should be connected to the emergency circuit to achieve this goal. Since egress doors open outward, light fixtures mounted above the door are an effective solution. Good practice calls for uniformity, glare control, and a gentle fall off of light from the threshold toward exterior pathways. Consult NYC codes for specific requirements. Additional lighting on the emergency circuit is recommended when the site adjacent to the building has level changes or hazards that may cause injury in total darkness. Controls: Although by law egress lights do not have to be activated except during an emergency, it is good practice to have at least one of the lamps on during normal hours of evening occupancy. A photocell override should be used to ensure that the exterior lamps are never burning during daylight hours.

### BUILDING RELATED ACTIVITY SPACES (HARDCAPED AREAS SUCH AS PATIOS):

Casual outdoor relaxation and seating areas that are adjacent to the building and used at night should be softly illuminated, with a minimum of glare, contrast or light trespass to the neighbors. For exterior break areas adjacent to an employee lounge, or outdoor seating adjacent to a residential community room, the spill light from the interior can often be used to light people's faces from at least one direction. For older eyes, face lighting should be supplemented from multiple directions, to avoid the silhouetting of a face when it is backlit by the building interior lights. The supplemental face lighting can come from pedestrian-scale (8-10'high) post-top fixtures at the perimeter of the hardscaped area. Lights mounted high on the

building, with the source shielded by cones or baffles can provide horizontal illumination over a wide area, but supplemental face lighting will still be required. Light colored ground surfaces are preferred. If a building contains residential units, the lighting of the exterior spaces shall not negatively affect the interior living spaces, especially the bedrooms.

## STAIRS AND RAMPS

People stumble on steps in broad daylight, so lighting is not the only factor in the safe navigation of level changes. Contrast between finishes on the walking surfaces plays a major role. The objective is to ensure that sudden changes in level, like steps and curbs, stand out from the adjacent hardscape. Using a lighter-colored material for the nosing of steps is the most effective strategy. Using rougher finishes and lighter colors on treads than risers and surrounding hardscape is another technique. Light fixtures, such as bollards, handrail lights or step lights are effective as markers for lighting steps, ramps, curbs or other hazardous conditions. At the very least, lights should mark the top and bottom of stairs and level changes.



The top and bottom of each set of risers is lit by step-lights recessed into the wall at landings.

The direction of light is important to enhance the perception of a level change. For example, light from the top of steps toward the bottom creates desirable shadows on the risers and back of steps, increasing the contrast between the upper nosing and the next lower plane. Light coming exclusively from the direction of the lower step distributes light into the riser and reduces the desired contrast. It is usually not possible to light steps uniformly, but every effort should be made to avoid glare and confusing patterns of light or shadow.

## LOADING DOCKS / TRASH AREAS

Care should be taken so that these spaces are not eyesores at night. As much attention should be given to glare control and light trespass on the rear of a building as the front. Use white light sources such as metal halide or fluorescent. Shield the view of sources from off the site whenever possible. In particular, control glare for truck drivers backing into loading docks. Consider special telescoping-arm task lights made for loading docks, which can be extended into the truck enclosure for loading and unloading. Controls: For areas that are not used after a certain hour, automatic astronomical time switch control is sufficient. If areas are used only infrequently at night, consider compact fluorescent (CFL) sources with occupancy sensors. For more frequent, but not continuous nighttime use, consider metal halide sources with two-level high-low ballasts or CFL sources, connected to occupancy sensors. Metal halide two-level ballasts are necessary since the lamps do not immediately re-strike after being turned fully off.

## PARKING LOTS

Open parking lots are most effectively lighted with pole-mounted luminaires. The lighting objectives are:

- Uniformity, to reduce harshness of shadow between cars
- Good color rendition, to improve visibility of motorists and pedestrians, and aid recognition of cars and people.
- Glare control for motorists and pedestrians
- Control of light trespass to neighbors and light pollution to sky.

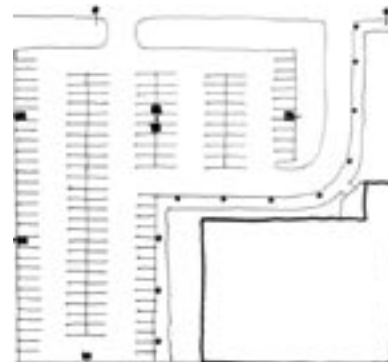

Sharp-cutoff luminaires at the perimeter of parking reduces glare and light trespass to neighbors.

For high-security parking lots, such as police stations, courthouses and jails, uniformity and good color rendering are more critical for good mesopic vision than are high light levels. Although increas-



It is quite common to specify luminaires with different distribution in the same parking area. The luminaires can still have the same outward appearance and use the same lamp.

and an asymmetrical (Type IV) or forward-throw distribution is best for driveways and the perimeter of parking lots. Poles located near the perimeter of the property should be aimed away from neighbors, and the luminaires fitted with “house-side shielding.” Parking lot entries, ticket booths and pedestrian pathways should have slightly higher light levels than parking areas, and automobile driving lanes can be slightly less, but transitions should be gradual.

**Controls:** Astronomical time switches or photocell overrides should be used to ensure that lights are only operated during times of occupancy and when daylight is no longer sufficient. Two-level high-low ballasts might be appropriate in some applications where light levels can be reduced at times but uniformity should be maintained. Avoid switching off alternate luminaires as this will increase contrast and decrease safety and security.

ing the height of poles improves uniformity, especially between cars, it also makes it more difficult to conceal the source from neighboring properties. Use more, shorter poles with lower wattage lamps, to improve distribution. Overlapping of beams between poles improves uniformity. Avoid tall, widely spaced poles and high-output lamps, as these reduce uniformity and increase the size and severity of shadows between cars. Metal halide lamps are usually the best source for parking lots. Reflectors inside the luminaires can provide a variety of beam patterns using one size of lamp. A wide symmetrical beam distribution (know as Type V) is usually best in the center of parking lots,

## WALKWAYS AND SIDEWALKS AND BIKEWAYS

The appropriate lighting scheme depends on adjacent lighting, hazards, and security concerns. Walkways don't always require continuous lighting especially in environments that are restricted to pedestrians or are in landscaped or park settings. Walkways and bikeways adjacent to roadways require more illumination, but may receive sufficient light from the street lighting. If lighting is discontinuous, luminaries should be placed at logical intervals that provide visual information, including intersections of pedestrians with other kinds of traffic, at path crossings, at benches or resting points, at curves, bridges or at changes in level. Avoid glare and light trespass. See additional comments under Security issues above. Controls: Astronomical time switches and/or photocell overrides should be used to insure lights are only operated when needed. The length of time such lights should operate is most often determined by security concerns. At times of low activity and in areas of low supervision (i.e., pathways not visible from residences or by security personnel), some design/owner teams have elected to install gates and post signs indicating the pathways are closed or not patrolled after a certain hour, and turn all the lights off. Otherwise, the lights might give the false impression that the pathway is more secure than it is. On urban or suburban streets, sidewalk lighting should be on from dawn to dusk.

## STORAGE YARDS

Storage yards should be lighted in a similar manner to parking lots, with poles located to light between the aisles of storage. For active nighttime storage access, avoid shallow angles of light that will create glare for the workers or forklift operators. Tall poles with low-wattage lamps provide the best distribution and comfort. Shield view of lamps or bright reflectors from motorists or residents. Controls: Carefully weigh the cost of energy against the effectiveness of running the lights all night in storage yards for security reasons. Light levels for security surveillance should be considerably lower than those designed for active nighttime storage activities. Two-level high-low ballasts could provide early evening storage activity lighting and after-hours security lighting (for guards or cameras) while retaining a uniform distribution.

## ENERGY CODE REQUIREMENTS

The Energy Conservation Code of New York State does not have an overall exterior power limit, but it does have an exterior lamp efficacy requirement, which states, “When the power for exterior lighting is supplied through the energy service to the building, all exterior lighting, other than low-voltage landscape lighting, shall have a source efficacy of at least 45 lumens per watt. Exception: Where approved because of historical, safety, signage or emergency considerations.” This effectively mandates certain types of lamps. (See Source Comparison Chart in the Overview section.)

The energy code requirements for ANSI/ASHRAE/IESNA Standard 90.1 are shown in the chart below. It should be noted that the same code or standard (i.e., NYS Energy Code or Standard 90.1) and the same version must be used for both the interior and exterior allowances and compliance. See Appendix A for more information.

FUNCTION	ANSI/ASHRAE/IESNA STD.90.1		NOTES
	- 1999 / 2001	- 2004	
Building Entrance with Canopy	3	3 w/ft <sup>2</sup>	1
Building Entrance without canopy	33 w/lin ft	33 w/lin ft	1
Building Exit	20 w/lin ft	20 w/lin ft	1
Parking Lots and Drives		0.15 w/ft <sup>2</sup>	1
Walkways 10' > wide		1.0 w/lin ft	1
Walkways 10' <, Plaza, Features		0.20 w/ft <sup>2</sup>	1
Stairways		1.0 w/lin ft	1
Main Entries		30 w/lin ft of door width	1
Other Doors		20 w/lin ft of door width	1
Canopies		1.25 w/ft <sup>2</sup>	1
Open Outdoor Sales		0.5 w/ft <sup>2</sup>	1
Street Frontage + open area		20 w/lin ft	1
Building Facades	0.25 w/ft <sup>2</sup> of illuminated façade area	0.2 w/ft <sup>2</sup> for each wall or 5.0 w/lin ft for each wall length	2

1 These values are multiplied by the square footage or lineal footage of each area, to arrive at a whole-building exterior allowance. In most cases, it is not necessary for each space type to comply with the individual values, as long as the total exterior allowance is not exceeded. 2. This allowance is considered “use it or lose it”. It cannot be traded off with any other power allowance.

## REFERENCES — SITE LIGHTING DESIGN

**The IESNA Lighting Handbook**, Illuminating Engineering Society of North America, Ninth Edition, 2000, Chapter 21.

**Guideline for Security Lighting for People, Property, and Public Spaces**, IESNA G-1-03, Illuminating Engineering Society of North America 2003, available at [iesna.org](http://iesna.org).



**Lighting for Exterior Environments**, IESNA RP-33-99, Illuminating Engineering Society of North America, 1999, available at [iesna.org](http://iesna.org).

**The Landscape Lighting Book**, Second Edition, 2005. Janet Lenox Moyer, John Wiley & Sons, Inc.

**Roadway Lighting**, ANSI/IESNA RP-08-99, Illuminating Engineering Society of North America, 1999, available at [iesna.org](http://iesna.org).

For reduced energy consumption, the following four-foot long fluorescent lamps are the DDC standard: 32 Watt T8, 3,100 lumen, CRI 85+, 3500 Kelvin, low mercury, extended life (24,000 – 30,000 hours). Note that DCAS (NYC Department of Citywide Services) will have available one of the following lamps: GE #F32T8 XL SPX35 HLEC (10326); Philips #F32T8/ADV/835/ALTO (13988-1); Osram/Sylvania #FO32/835/XPS/ECO (21697).

## SAMPLE LUMINAIRE SCHEDULE FOR BUILDING EXTERIORS

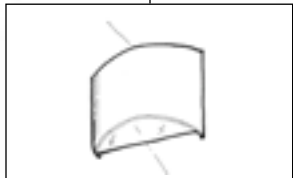
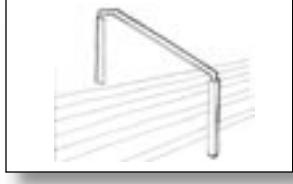
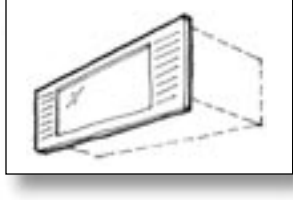
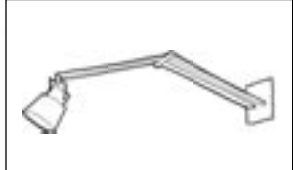
	<p><b>POLE-MOUNTED PARKING/SITE FIXTURE (“SHOE-BOX” STYLE)</b></p> <p><b>Location:</b> Parking Lot, Site  <b>Lamps:</b> (1) 100w ED-17 ceramic metal halide, 3200 – 5000 Kelvin  <b>Description:</b> Pole-mounted ceramic metal halide road/area fixture. Mount head a minimum of 12’ AFG and a maximum of 24’ AFG. Full-cut off, differentiated optics and distribution. House-side shield. Wet location rated.</p>
	<p><b>BOLLARD</b></p> <p><b>Location:</b> Paths, Building Entrances  <b>Lamps:</b> (1) 50W ED-17 ceramic metal halide, 3200 – 5000 Kelvin  <b>Description:</b> Footing-mounted area fixture not to exceed 48” in height. Louvers and/or lens for optical control and glare mitigation. Wet location rated.</p>
	<p><b>“CENTRAL PARK” OR “BPC” STYLE POST-LANTERN</b></p> <p><b>Location:</b> Paths  <b>Lamps:</b> (1) 100w ED-17 ceramic metal halide, 3200 – 5000 Kelvin  <b>Description:</b> Post-top period ceramic metal halide fixture, impact resistant polycarbonate lens. Luminaires to match NYC Central Park or Battery Park City (BPC) style fixture. Horizontal mounted lamp in top of fixture. Minimum pole height 8’ AFG and maximum pole height 16’ AFG. Specify full-cutoff, differentiated optics. Wet location rated.</p>
	<p><b>WALL FIXTURE OVER DOORS</b></p> <p><b>Location:</b> Exterior doors  <b>Lamps:</b> (1) 50W ED-17 ceramic metal halide, 3200 – 5000 Kelvin  <b>Description:</b> Surface-mounted, arm-bracket, ceramic metal downlight. Shielded for full cutoff. Wet location rated.</p>
	<p><b>HANDRAIL LIGHT</b></p> <p><b>Location:</b> Stairs  <b>Lamps:</b> (1) 28W, T5, 835-850 color  <b>Description:</b> Fluorescent lamp recessed into handrail with lens. Integral ballast in handrail. Wet location rated.</p>
	<p><b>RECESSED STEP LIGHTS</b></p> <p><b>Location:</b> Stairs  <b>Lamps:</b> (1) 50W ED-17 ceramic metal halide, 3200 – 5000 Kelvin  <b>Description:</b> Recessed into wall, ceramic metal halide step light with prismatic lens or louver. 120v integral ballast. Mount a minimum of 12” above the step, 18” preferred.</p>
	<p><b>LOADING DOCK LIGHT</b></p> <p><b>Location:</b> Loading Dock Wall  <b>Lamps:</b> (1) 60W Par-38 Halogen or CFL integrally-ballasted floodlamp.  <b>Description:</b> Surface-mounted, adjustable-arm in three axes to aim into truck bed. Powder coated yellow for safety.</p>

# PARKING GARAGE LIGHTING DESIGN BRIEF

The NYC Department of Design and Construction (DDC) manages the construction and renovation of NYC’s building stock throughout the five boroughs. These guidelines apply to the free-standing, above-ground parking structures that are built on New York City property, but not to the open parking lots that might be adjacent to them. (See Building Exterior Lighting Design Brief for information on the lighting of open parking lots.) These garages are typically managed by outside parking contractors who have a service contract to operate and maintain the facilities. In addition to the covered parking areas and driving lanes, parking garages have one or more control booths, a management office, public toilets, stair towers, and roof-top parking.

## LIGHTING QUALITY STRATEGIES

Parking Garages have specific considerations because of their function and spatial characteristics. The rapid transition from interior to exterior conditions, especially on a sunny day, creates a challenge for drivers that must be considered in the lighting design. Low ceilings make it difficult to control glare from light sources. A building with open perimeters loses valuable reflecting surfaces, while creating unwanted opportunities for light pollution and trespass. Lighting is often required 24-hours per day, making energy efficiency, maintenance and vandalism protection particularly critical. Finally, outdoor conditions such as moisture, temperature extremes, road salt and vibration constrain the selection of luminaires.

Please review and use these guidelines, in concert with the basic issues of lighting quality and design strategies set forth earlier in the Design Team Strategies section of this Lighting Manual. In addition, portions of other Design Briefs will be relevant, including those for Building Exteriors (for open parking lot recommendations), Offices, Stairs and Toilets.



photo: Edward Hueber/archphoto, courtesy: Zumtobel Lighting, Inc.

## PARKING GARAGES – SPECIFIC LIGHTING QUALITY ISSUES

ISSUE	IMPORTANCE
Glare Control	Very Important
Light Pollution/Trespass	Very Important
Uniformity – Reduction of Shadows	Very Important
Peripheral Detection	Very Important
Wayfinding	Important
Luminances and Reflectances of Room Surfaces	Important
Color	Somewhat important

Chart adapted from IESNA Lighting Handbook, 9th Edition.

### Glare Control

Glare results from excessive contrast between extremes of brightness and darkness. In most cases, glare is merely annoying. But it can be dangerous in a garage if it is severe enough to become temporarily disabling, especially to a person operating a multi-ton moving vehicle. Several conditions can cause glare



in parking garages. The sudden change in illuminance levels between the daylighted exterior and the darker interior can temporarily blind a driver and put pedestrians at risk. Bright luminaires located at wide intervals cause glare, because the viewer has trouble maintaining a consistent level of eye adaptation – it is similar to meeting oncoming headlights on a dark road. Glare can be mitigated by shielding luminaires in the direction of travel; by using more sources of greater brightness that can be comfortably viewed without shielding; and by keeping the luminaires out of the center of the driving lanes. The relationship of bright luminaires to the view of guards or security cameras should also be considered.



Avoid locating luminaires in the center of driving lanes.

### Light Pollution and Light Trespass

Refer to the Exterior Lighting Design Brief for more detailed discussion of “light pollution” (unnecessary light into the sky) and “light trespass” (bright visible sources or light spilling into neighboring properties). Both are concerns in lighting parking garages because of their often largely open perimeters. Light pollution wastes energy and is a disruption to the human and animal environment. Light trespass not only annoys neighbors, but can also disturb their sleep patterns. Consequently, the location, selection, and distribution of lighting need to be carefully selected to avoid these problems. Luminaires near the open perimeter should be shielded to prevent light from distributing above head height at the openings. Choose roof-top parking fixtures with a specific distribution patterns fitting the shape of the area to be lighted, rather than a fixture where light leaves the fixture in any direction.

### Uniformity and shadow reduction

To aid both visual and electronic surveillance, shadows should be minimized for safety and security. Luminance ratios should be no more than 10:1 between maximum and minimum, calculated in an empty facility, without obstructions. In actual garages, parked vehicles create significant obstructions, so greater uniformity is preferred. Greater uniformity also reduces energy consumption, since light level recommendations are based on exceeding minimum values everywhere, the greater the uniformity, the closer the average level will come to the minimum level. Glary sources, or excessively high light levels should be avoided, because they will prevent the bright-adapted eye from focusing into shadows. Greater uniformity and reduction of shadows improves peripheral vision, increases security and reduces pedestrian apprehension.

### Color and Peripheral Detection

In parking garages, the color of light sources should result in a natural appearance of people and vehicles. Users often have trouble identifying their cars under light sources with poor color rendering characteristics, such as high pressure sodium. Specify sources with a color rendition index (CRI) of 65 or better. Lamps that provide light in the bluer range (like fluorescent and metal halide) are preferable for nighttime visual acuity, and also aid in peripheral detection. Identifying pedestrians and moving cars on the periphery is a critical task while driving and parking a vehicle. Avoid high-pressure sodium (HPS) lamps and use fluorescent, metal halide, or induction light sources with a correlated color temperature (CCT) between 3200 and 4100 Kelvin.

### Luminance of Room Surfaces; Reflectances and finishes

The luminance of light emitted from sources or reflected off surfaces is perceived as brightness, and uniformly-lighted surfaces in a garage reduce contrast and shadows. Lighted ceilings increase visual comfort by reducing the contrast between luminaires and their background. Lighted upper walls reduce contrast between bright daylight openings and promote inter-reflections that reduce the shadows between cars. The brightness of interior garage surfaces is positively connected to the occupants’ feeling of security in a parking garage. Brightness is directly proportional to the reflectance value of surfaces, so every surface in view (and in the control of the design team), should be as light-colored as possible. All ceilings, beams columns and walls should be painted white, with limited use of contrasting colored bands where needed for wayfinding or caution. Polished, glossy and shiny surfaces should be avoided because they cause glary reflections. The most

matte finish available that will provide acceptable maintenance should be used. Use matte concrete paint or anti-graffiti coatings. Metal surfaces should be heavily brushed or painted white. It should be noted that flat concrete ceilings create a better luminous environment than waffle slabs. Since the light does not get trapped within the coffers, the lighting is more uniform, and up-lighting is more effectively distributed.

### Way Finding

Parking garages can be confusing places and lighting can assist in orienting the user, along with signage and color. Consider using a distinctive lighting approach to identify stairs and exits for pedestrians. Color-coding is an effective method to identify different levels, stairs/exits and pedestrian walkways. Bands of color on columns and walls are preferred, since large areas of saturated color will absorb vertical illumination and reduce desirable inter-reflections.



Colored signage and architectural valance.

### Visual adaptation levels

During the daytime, a driver entering a covered parking garage will be adapted to bright light, and will have a hard time seeing detail when suddenly entering a darkened space. The entrances to parking garages should consider luminous “transition zones”, like the entrances to tunnels. To ease this transition, a significantly higher level of electric lighting or reflected daylight should be located within the first 65’ of the entrance. These lights should be controlled by an astronomical timeclock or photocell, so that they decrease at night to match the general ambient level within the garage.

## LIGHTING DESIGN AND LAYOUTS

### Car Parking Areas

Except in cases where attendants park all the cars, the general parking areas of a garage have multiple locations where pedestrians and autos interface (and potentially conflict). Consequently, the lighting layouts should promote comfort and visibility. There are two primary approaches to garage lighting – locating luminaires in the center of drive lanes or locating them on the sides. The first is popular because half the number of luminaires with twice the wattage can be used, reducing initial costs. The resulting light quality is so poor, even with well-designed luminaires, that this method is not recommended for NYC parking garages. Designers should locate luminaires on the sides of the driving lanes and ramps. More luminaires with lower brightness will typically provide greater comfort and uniformity. Limiting the power to 100 watts or less per luminaire is a good rule of thumb, although higher wattages may be appropriate for entrances or roof-top parking luminaires.

Parking garage luminaires are of two primary types – linear and point. Linear fluorescent luminaires are the current standard for the parking structures of the Port Authority of NY/NJ, and are used throughout Europe. Although many US garages installed point source luminaires in the last three decades, they have not matched linear luminaires for the general quality of light. The advantages and disadvantages are outlined in the box below. In NYC more garages are renovated than built, and the designer should evaluate and select the most appropriate system for the given conditions, rather than simply replacing the existing system with new luminaires of the same type. In some cases, it may be useful to compare quality, quantity, costs, maintenance characteristics and energy efficiency of more than one layout, lamp type, or luminaire type. Ballast input wattage and temperature effects must be included in any comparison. Both T8 and T5 lamps may be appropriate for linear garage luminaires – the former performs better in cold weather, and the latter performs better in warm weather. Consideration should be given to the high performance T8 lamp stocked by NYC for DDC projects. (See the Sample Luminaire Schedule below). The point source luminaires are often available in a variety of distributions which shape and direct the light, rather than emitting in only a circular pattern. This may achieve a more uniform distribution of light into corners, at least in an empty garage. Pulse start ceramic metal halide and induction lamps are the DDC-preferred sources for point luminaires.

FIXTURE / SOURCE	ADVANTAGES	DISADVANTAGES
<b>Sealed fluorescent luminaires</b>  Linear Distribution	<ul style="list-style-type: none"> <li>• Lower brightness</li> <li>• Better uniformity</li> <li>• Brighter wall/ceiling surfaces - security</li> <li>• Instant re-strike if power lost</li> <li>• Shallower for low ceilings</li> <li>• Long life (20,000 hours plus)</li> <li>• High lumen maintenance</li> <li>• Lower cost lamps, ballasts, components</li> <li>• Highest efficiency in normal temps</li> <li>• Uniformity better if one lamp burns out</li> </ul>	<ul style="list-style-type: none"> <li>• Reduced lumen output in low temperatures</li> <li>• More lamps to replace</li> </ul>
<b>Metal Halide point luminaires</b>  Point Distribution	<ul style="list-style-type: none"> <li>• Fewer fixtures</li> <li>• Glare shielding from many angles</li> <li>• Fits in coffers of waffle slab</li> <li>• Constant light output, even in cold temps</li> <li>• Various distribution patterns available</li> </ul>	<ul style="list-style-type: none"> <li>• Highest brightness concentrated into point source</li> <li>• Requires auxiliary quartz system for re-strike</li> <li>• Deeper (10-15") – problem for low ceilings</li> <li>• More expensive lamps and ballasts than FL</li> <li>• Low wattage lamps less efficient than fluorescent</li> <li>• Lower lumen maintenance</li> <li>• Shorter lamp life (15,000 to 20,000 hours)</li> <li>• Cannot burn continuously. Requires timed off</li> <li>• Larger dark area if lamp burns out</li> </ul>
<b>Induction lamp point luminaires</b>  Point Distribution	<ul style="list-style-type: none"> <li>• Longest component life (100,000 hours)</li> <li>• Instant re-strike</li> <li>• Glare shielding from many angles</li> <li>• Fits in coffers of waffle slab</li> <li>• Constant light output, even in cold temps</li> <li>• Various distribution patterns available</li> </ul>	<ul style="list-style-type: none"> <li>• Proprietary lamp specification</li> <li>• Three separate components</li> <li>• Components fail at different rates</li> <li>• Less efficient than MH or FL</li> <li>• Lower lumen maintenance than FL</li> <li>• More expensive first cost and components</li> <li>• Larger dark area if lamp burns out</li> </ul>

If the traffic direction is one-way, it may be acceptable to locate some low wattage luminaires in the center of the drive lane, fully shielded from the driver (by reflectors, valances or beams), distributing light asymmetrically in the direction of travel. Waffle-slab construction prevents uniform lighting of the ceiling, so more luminaires and more power may be necessary to provide acceptable quality and distribution. In particular, additional lighting may be required on upper walls, to increase the sense of security and prevent the "cave effect". Finally, curved ramps should be lighted from the side, with linear fluorescent or CFL luminaires. Uphill ramps require greater shielding due to the raised angle of the drivers line of sight. For example, even step lights on uphill ramps can be within the driver's view.

### Garage Entries and Exits

Entrances are critical zones of transition between bright daylight and a shaded interior environment. The contrast between a sunny street and the average garage interior can be as much as 5000:1. Consequently, the minimum light levels at the entry should be 50 times that of the rest of the garage. This can be accomplished by using a different luminaire type, or by locating a large quantity of closely spaced parking luminaires. Daylight should be included in the calculations, so that electric lighting is only used to make up the difference. Designs that increase the penetration of daylight deep into the entrance should be considered in new garage construction, since this will reduce the area that needs to be brightly lighted. Due to the high energy consumption required for transition zones, the number of entries should be limited. A garage design that has multiple driving lanes flowing continuously between an outdoor parking lot and a covered structure can be prone to accidents and is very energy wasteful.



Increase light levels at entry

Exiting is a somewhat different story. The transition from a dimmer parking garage out to the brighter daylight results in much faster eye adaptation, so increased light levels are only necessary at the approach

to the booth and/or gate. This transitional lighting should only operate during hours of full daylight. High levels of light in a transition zone at night will create hazards of its own for drivers, making it more difficult for them to see detail under the lower light levels beyond.

### Attendants' Booths

Within the booth, the attendant should be lit sufficiently to be obvious to drivers, but not overly lit so that internal reflections on the glass obscure the view out. It is essential to design lighting that maximizes the ability of the attendant to see out through the windows. Interior booth lighting should be low level, and adjustable between night and day. Local task lighting is an effective way to maintain the attendant's capability for surveillance. Overhead luminaires should be shielded to avoid "veiling" reflections on the glass, that is, reflections that obscure the view out. Indirect lighting should be studied to ensure that the lighted ceiling or room surfaces do not reflect at important places in the glass. The design of the booth windows should block the attendant's direct view of the garage ceiling luminaires, especially where luminaire density is increased at the entries. If this is a problem in existing facilities, shades should be provided. For windows exposed to sunlight, consider using heavily tinted Mylar shades so that the shades can be raised for visibility at night rather than using tinted glass.

### Rooftop parking

Rooftop parking should meet the same criteria as open parking lot lighting, with special consideration for the visibility of fixtures from lower elevations. See the Exterior Lighting Design Brief in this Manual for these recommendations.

### Pedestrian walkways

Whenever possible, it is important to identify specific pathways for pedestrians, especially at locations with the highest occurrences of interactions with autos. Brightly colored stripes on the floor are effective, coupled with a change of light or an increase of light at crosswalks.

### Stairs, Elevators and Public Toilets

Lighting can be effective for emphasizing the vertical walls of the stairs or elevator cores so they can be identified from a distance, and to orient pedestrians within the space. Architectural valances or signage can be coupled with lighting to reduce glare and increase visibility. See the Stair and Corridor Brief for recommendations for lighting within stairways, and the Toilet, Locker and Shower Design Brief for recommendations within public toilets. Depending on the specific likelihood of vandalism and security procedures, the luminaires in these spaces should be selected to resist vandalism. Wet location rating is advisable, but not required.

## LIGHT LEVELS - RECOMMENDED MINIMUM ILLUMINAICE, IN FOOTCANDLES (FC)

FUNCTION	MINIMUM HORIZONTAL FC <sup>2</sup>	MAX:MIN HORIZONTAL UNIFORMITY RATIO <sup>3</sup>	MINIMUM VERTICAL <sup>5</sup> FC <sup>4</sup>
Basic <sup>1</sup>	1.0	10:1	0.5
Roof Level open to sky	0.5	15:1	.25
Ramps <sup>6</sup>			
Day	2.0	10:1	1.0
Night	1.0	10:1	0.5
Entrance Areas <sup>8</sup>			
Day <sup>7</sup>	50.0		25
Night	1.0	10:1	0.5
Stairways	2.0		1.0

Values taken from the IESNA Lighting Handbook, Ninth Edition, and RP-20-98 Lighting for Parking Facilities. 1. For typical conditions. 2. Minimum "maintained" footcandles measured on the parking surface, without any shadowing effect from parked vehicles or columns. May require 3-5 fc average. 3. The highest horizontal illuminance area, divided by the lowest horizontal illuminance point or area, should not be greater than the ratio shown. 4. From enhanced security parking lot requirements. 5. Measured at 5.0 feet above parking surface at the point of lowest horizontal illuminance, excluding facing outward along boundaries. 6. Applies only to clearway ramps (with no adjacent parking) but not sloping floor designs. 7. Daylight may be considered in the design calculation. 8. A high illuminance level for about the first 65 feet inside the structure is needed to effect a transition from bright daylight to a lower interior level.

## SPECIAL CONSIDERATIONS FOR PARKING GARAGES

### Sealed lamps and luminaires

The lighting equipment specified for parking garages must be suitable for the typical conditions of moisture, temperature and atmosphere typically found in New York City. Sealed and gasketed construction can shield the lamp and electrical components from the corrosive impact of road salt, humidity, and vehicular emissions, and can protect lamps from breakage by antennae or vandalism. A wet-location rating can also protect the luminaire when a facility is hosed down with high-pressure water or steam. An Ingress Protection rating of IP 55 to 56 is preferred. (See box). Well-sealed luminaires, including those with entirely sealed lamp sleeves (“jacketed”), hold the heat and stay warmer in cold weather, increasing the light output of fluorescent lamps. The thermal performance of entirely enclosed luminaires can be further improved in winter by the use of short sleeves that cover the “cold spot” of a fluorescent lamp, which is especially useful for T5 lamps. (See Sample Luminaire Schedule for Parking Garages, page 94). Obtain lumen output performance data under cold ambient temperatures from luminaire manufacturers.

#### Ingress Protection IP Rating for Equipment and Enclosures:

A two-digit number where the first represents protection against solid objects and the second represents protection against liquids. A first number of 5 (out of 6) represents partial protection against dust ingress with no harmful deposits. The second digit of 5 or 6 (out of eight) represents protection against low-pressure and high-pressure water jets, respectively, from any direction.

### Luminaire distribution options

In garages with flat or structural T ceilings, select luminaires that distribute a portion of their light onto the ceiling and upper walls. This increases inter-reflections, reduces shadows, reduces contrast between bright luminaires and their backgrounds, and improves the appearance and security of a garage. When luminaires are located within the coffers of waffle-slabs, uplight is wasted and reduces the efficiency of the luminaires. For these locations, select linear fluorescent fixtures with a narrower distribution, and/or metal halide and induction lamp luminaires with a downlight distribution, with no uplight.

### Vandal resistant luminaires

Special luminaires are available for use in areas subject to vandalism, such as stairwells or restrooms. These fixtures should have:

- Sturdy construction so they cannot be easily destroyed or the lighting disabled.
- Tamperproof construction, mounting and access, to avoid access to electricity, or parts that can be stolen or used for weapons or vandalism.

### Emergency battery packs

Provide emergency battery ballasts to active lights in case of loss of normal power for up to 90 minutes, according to code. Emergency fixtures should be located in the public restrooms, office, booth, and along the normal path of egress. Metal Halide luminaires will also require auxiliary emergency lights, typically quartz halogen, to operate until the HID source can cool down, re-strike, and return to full output.

## ENERGY EFFICIENCY STRATEGIES

### Daylighting

Adjacent buildings often obstruct daylight in an urban environment. The design of existing NYC parking garages also may limit opportunities for reducing electrical usage by daylight harvesting. However, despite large floor plates and low ceilings, daylight may penetrate 30 to 50' into the interior if the top of the perimeter openings approach the height of the ceiling. Consider photosensor/switching controls on the row of luminaires closest to the perimeter if daylight is calculated to provide 10-15 footcandles at least 30' into the interior. In some areas, it may be necessary to leave electric lighting on during the day to reduce the contrast between the bright exteriors and dimmer interiors. In the design of new parking structures,

utilize as much daylight as possible. Consider shallow designs and internal light wells. When the quantity and quality of daylight is acceptable, control electric lighting so that it is not operating during those times. (See controls, on page 92).

### Increase surface reflectances

The use of light colored finishes on interior garage surfaces not only improves visual comfort and increases the perception of security, it also utilizes the light more efficiently by reducing wasteful absorption. Paint ceilings, columns and interior walls white.

### Separate the monthly parking stalls from daily parking

Locate all parking spaces rented on a monthly basis in a concentrated area closer to the entrance or area of high activity or visibility, so that after-hours lighting to prevent theft and vandalism can be isolated to a fraction of the entire structure.

### Reduce security lighting

Avoid operating all lights at full output after operating hours for security. Surveillance cameras and the human eye are capable of detecting motion and intruders at 1/10th of a footcandle, in the absence of glare or high contrast. Consider other forms of security rather than lighting as a deterrent to trespassing after hours. Occupancy sensors can be used to turn lights on (or increase the light level) if motion and/or heat from intruders are detected.

## ENERGY CODES – WATTS PER SQUARE FOOT ALLOWANCES

FUNCTION	ENERGY CONSERVATION CONSTRUCTION CODE OF NEW YORK STATE		ANSI/ASHRAE/IESNA STD.90.1		NOTES
	-2002	+/-2007	-1999/2001	-2004	
Whole-building - Garage		0.3	0.3	0.3	1
Parking Area – Pedestrian			0.2		2,3
Parking Area – Attendant Parking Only			0.1		2,3
Garage Area				0.2	2

1) 2007 revision of ECCC NYS only lists a value for Whole Building category for a parking garage—no value is listed for 2002. 2) ANSI/ASHRAE/IESNA Standard 90.1 lists these categories. No similar categories listed for ECCC NYS. 3) Parking area categories are listed in Standard 90.1-2001, but changed to “garage area” in Standard 90.1-2004.



Colored signage and architectural valance.

photo: Thomas Filler, courtesy: Zumtobel Lighting, Inc.

## LIGHTING CONTROLS

Separately wire and control those lights needed for regular operation, from those used for daytime transition, security, and emergency requirements.

### Occupancy Sensors

Parking garages have intermittent activity and many periods when a vast majority of the space is unoccupied. If lighting is desired after hours of operation in order to prevent vandalism for monthly tenants, occupancy sensors should be used, activated after hours by a timeclock. Lighting should be grouped so that most of the lights can be turned off via occupancy sensor without the all of the lighting turning off. Fluorescent lamps work well with occupancy sensors, except in very cold temperatures when the lumen output is significantly reduced at start-up. Consequently, some fluorescent lamps or luminaires should be lighted on a 24-hour basis, but only in the winter. Metal halide and fluorescent luminaires can be fitted with high/low ballasts that will operate at reduced output, but with a uniform distribution. Motion will instantly increase the lamp to full output. Specify dual technology occupancy sensors. The ultrasonic sensing is most effective in areas obstructed by walls, columns and cars, and the passive-infrared is recommended due to the open perimeters.

### Astronomical Time Clocks

Lighting on the roof or perimeter of the parking garage may not be needed during the day, but is required for some portion of the night. Transitional lighting at the entrance is on the opposite schedule. An astronomical timeclock can be set to turn lights on or off near dusk or dawn. Astronomical timeclocks can also be used to activate occupancy sensors or photosensors.

The manufacturers of metal halide lamps recommend turning them off for 15 minutes once per week when under continuous operation. This procedure reduces the risk of arc tube rupture at the end of life. Design the zoning of these fixtures so that the time-clock can perform this operation after hours, on a rotating schedule, to prevent the entire facility from being darkened at the same time.

### Photosensor Controls

If areas of the garage, such as the perimeter, are adequately and comfortably lighted by daylight on a regular basis, and certain electric lights can be turned off without creating a condition of excessive contrast, place those lights on separate control zones. Typically, different orientations of openings will provide positive daylighted conditions at different times, so electric lights on each orientation should be separately zoned. An “open-looped” photosensor switching control system should be considered, with a wide “dead-band” to avoid cycling and shortened lamp life. (See the Manual for daylighting terminology). Daylight switching should be limited to fluorescent and induction lamps, or metal halide luminaires fitted with high/low ballasts. Continuous dimming is seldom cost effective at the low watts per square foot levels used in garages, but multiple-level switching may be cost effective in some conditions.

### High/Low Metal Halide Ballasts

Metal halide lamps have a warm-up time that must be factored into the operation of garage luminaires. Initially, it takes a few minutes for the lamp to achieve full output. If power is interrupted once the lamp is warmed up, it can take up to 10 minutes for the lamp to cool down, “re-strike”, and regain full output, making the lamp inappropriate for emergency lighting, switching or occupancy sensor control. For switching strategies, two-level high/low ballasts can be used to quickly modify the output of a lamp from 50% to 100%. While magnetic high/low ballasts reduce the light output by roughly 50%, they do not actually reduce the energy consumption by the same percentage (typically the power consumption is reduced only by 25%). Electronic high/low ballasts now exist that provide a reduction in power that is similar to the reduction in light output. Any reduction in power to metal halide results in a shift of color. When power is reduced below 60%, the color shift of metal halide lamps becomes noticeable, toward the blue-green part of the spectrum. Note that a high/low ballast does not re-strike the lamp instantly once the power is lost. Therefore, if metal halide is used, regardless of the ballast type, auxiliary lamps are still required for emergency luminaires.

## OPERATIONS AND MAINTENANCE STRATEGIES

### Special Maintenance and Operational Issues

Design the lighting system with maintenance in mind. NYC garages are operated by garage management firms who must comply with strict DOT maintenance procedures. If the design for the garage lighting is not sensitive to maintenance issues, it will affect the bids of potential operators for the management contracts, resulting in lower profit for the City. Select luminaires that are resistant to vandals, but easy to maintain with the correct tools. Any adjustable hardware should be “captive” so that it does not fall out of the luminaire when loosened, and lenses should be hinged or attached to safety chains.

### Dirt Depreciation

Garages are inherently dirty, so DOT contracts require parking operators to regularly clean the garage surfaces. Consequently, an environmental classification of “dirty” rather than “very dirty” should be used for Dirt Depreciation calculations for NYC garages.

### Re-lamping

Since contracts for operations only extend for three to five years, and the operators are responsible for prompt re-lamping of burned out lamps, there is currently little incentive for group relamping. The City’s garage management contracts should require group-relamping of metal halide and induction lamps, because the lumen maintenance over the life of the lamp drops significantly after about 70% of rated lamp life. High performance fluorescent lamps maintain a higher percentage of their light output over a long time, so group re-lamping of fluorescents may not be cost effective for garages.

### Commissioning

The lighting controls should be thoroughly commissioned prior to operation. Most garage lighting projects are in existing facilities that must remain in operation during renovation, so the commissioning is often done in multiple stages, and then a final check performed once all upgrades are installed. Re-commissioning should be scheduled for every contract renewal, or every two years, whichever is sooner.

## REFERENCES

1. Lighting for Parking Facilities, IESNA Recommended Practice RP-20-98, Illuminating Engineering Society of North America.
2. IESNA Lighting Handbook, 9th Edition, Illuminating Engineering Society of North America, Editor Mark Rea.

For reduced energy consumption, the following four-foot long fluorescent lamps are the DDC standard: 32 Watt T8, 3,100 lumen, CRI 85+, 3500 Kelvin, low mercury, extended life (24,000 – 30,000 hours). Note that DCAS (NYC Department of Citywide Services) will have available one of the following lamps: GE #F32T8 XL SPX35 HLEC (10326); Philips #F32T8/ADV/835/ALTO (13988-1); Osram/Sylvania #FO32/835/XPS/ECO (21697).



## SAMPLE LUMINAIRE SCHEDULE FOR PARKING GARAGES

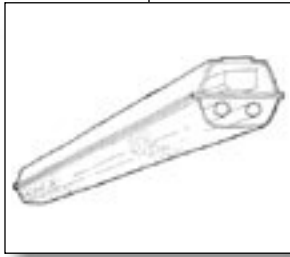

### FLUORESCENT SEALED AND GASKETED

**Location:** Parking Areas  
**Lamps in profile:** (2) 32W, High-Performance T8, 835 color, extended life, low mercury.  
**Description:** Surface-mounted fluorescent luminaire in lengths of 4'-0" to 8'-0" using 4' lamps only. White baked enamel housing and prismatic lens. Sealed and gasketed. Vandal-resistant hardware when required. Electronic 0° F start two-lamp ballasts. Emergency battery backup ballasts where indicated.

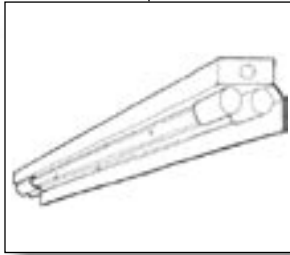

### FLUORESCENT STRIP WITH SEALED SLEEVES

**Location:** Parking areas  
**Lamps in profile:** (1) or (2) 32W, High-Performance T8, 835 color, extended life, low mercury. Consider a combination of lamp and sealed jacket. (eg: GE's "Arctic Lamp")  
**Description:** Surface-mounted fluorescent luminaire in lengths of 4'-0", 8'-0" using 4' lamps only. Baked enamel housing. Sealed and gasketed lamp holders with 1-1/2" diameter clear acrylic sleeve. Optional side shield and reflector. Vandal resistant housing when required. Electronic 0° F start two-lamp ballasts. Emergency battery ballasts where indicated.



### GARAGE LUMINAIRE FOR HID OR INDUCTION LAMPS

**Location:** Parking areas  
**Lamps in profile:** (1) 70-100 watt metal halide, 3200K or (1) 55-85 watt induction lamp.  
**Description:** Surface mounted (or pendant- or trunion-mounted) luminaire designed specifically for parking garages. Separate upright optics for most applications, and cut-off downlight reflector. Distribution pattern as required. Specify generator, glass vessel and power coupler for induction lamp. Emergency battery backup where indicated. Auxillary lamp for metal halide luminaires on emergency systems.

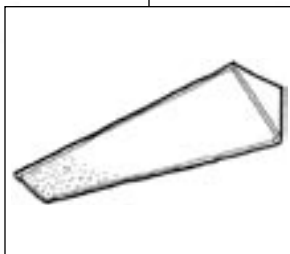

### FLUORESCENT CORNER ENCLOSED

**Location:** Parking Areas, Ramps, Stairs  
**Lamps in profile:** (1) or (2) 32W, High-Performance T8, 835 color, extended life, low mercury.  
**Description:** 4'-0" long wall-mounted fluorescent, sealed and gasketed. Wet location and vandal resistant design where required for egress corridors. If luminaire extends more than 4" into path of egress, mount bottom of fixture at 6'-8" to meet ADA requirements. 0° F start ballast where required. Emergency battery backup ballasts where indicated.

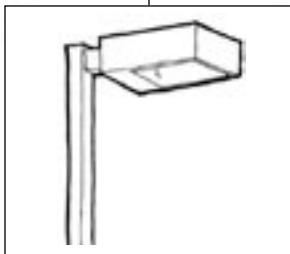

### ROOFTOP POLE MOUNTED SHARP CUTOFF LUMINAIRE

**Location:** Roof-top parking  
**Lamps:** (1) 100-175 watt metal halide, 3200K or (1) 85W-165W Induction lamp  
**Description:** Mounted on poles 12' to 18' above parking surface, with one to two luminaire heads per pole. Full cut-off optics and house-side shielding where required to prevent light pollution and light trespass. Three components (generator, power coupler and glass vessel) for induction lamp. Two-level high-low metal halide ballast, rated for -20° F start. Emergency battery ballasts where indicated, and auxiliary emergency system for metal halide luminaires, when EM is required.

## FIREHOUSE LIGHTING DESIGN BRIEF

The NYC Department of Design and Construction (DDC) manages the construction and renovation of NYC's municipal buildings, which include FDNY firehouses. These guidelines cover the lighting design of dormitories, kitchens, dining rooms, sitting areas and the vehicle apparatus rooms in firehouses. Some of these recommendations may be applicable to EMS facilities and other similar settings for emergency response personnel, but may not be appropriate for similar space-types elsewhere. Please review and use these guidelines, in concert with the basic issues of lighting quality and design strategies set forth earlier in the Design Team Strategies section of this Manual. In addition, portions of several other Design Briefs will be relevant, including those covering Offices, Corridors and Stairs, Toilets, Lockers and Showers, Warehouses and Building Exteriors.

### LIGHTING QUALITY STRATEGIES

Firehouses have special lighting considerations because of their function and spatial characteristics. Both residential and industrial in character, they are even classified into two NYC zoning categories, Dormitories D-2 and Garage J-2. Unlike public facilities, users are very familiar with their surroundings, both day and night. Considerations for firefighters' comfort, health and safety should be paramount, resulting in lighting designs with less glare, greater flexibility through lighting controls, and occasional duplication of systems for different functions or times of day. The living, dining, and sleeping areas should have a warm and inviting ambiance. Finally, due to the residential nature of firehouses, the non-visual ("photobiological") effects of lighting should be considered.



### Photobiology

Along with other job stresses and dangers, firefighters and other emergency personnel are subject to sleep interruption during nighttime hours, coupled with the need for a rapid return to alertness when an alarm occurs. Lighting may provide a degree of help. It is known that at night, a restorative sleep cycle is a function of a hormone called "melatonin", which benefits from total darkness. Every morning, our biological clocks are reset by exposure to bright light, which shuts off the melatonin production, increasing alertness. Bright light has been used to treat jet lag and wintertime depression. More research is underway to understand the exact role of light in sleep. While the therapeutic use of light for sleep disorders looks promising, research is still studying the appropriate intensity, duration, and optimal time of day for light therapy. Recent studies suggest that melatonin production is sensitive to the color (or wavelength) of light as well as the intensity. It is most sensitive to blue wavelengths, so the same quantity of blue light will stop melatonin production more quickly than other colors. Conversely, the human photobiological system appears to be least sensitive to red or orange wavelengths, so red or deep amber lights in a sleeping area would be the least disruptive to the sleep cycle. For the purposes of this guide, even these preliminary research results warrant the consideration of red nighttime lights to reduce unnecessary disruptions to sleepers.

### FIREHOUSES - SPECIFIC LIGHTING QUALITY AND ISSUES

ISSUE	IMPORTANCE
Daylighting and Connection to Out-of-Doors	Important
Glare and Visual Comfort	Important
Light Distribution on Surfaces	Important
Color Appearance (and Color Contrast)	Important

Chart adapted from IESNA Lighting Handbook, 9th Edition, for Fire Stations and Residences categories.

## Daylighting and Connection to the Out-of-Doors

Since a firehouse serves as a part-time residence, the characteristics of healthy homes should be included in the architectural design. One important element is the provision of windows for daylight, view and connection to the outside environment. Light and color rhythms from sunrise to sunset, dynamic changes in weather, and bright light all benefit human health. Windows are particularly important in dining areas and exercise rooms, to help reset the occupants' biological clocks in the mornings. On the other hand, emergency workers are frequently out-of-doors in the line of duty, so the criteria for windows may not be as critical as other residential applications. Daylight is also a pleasant, effective, and energy-conserving light source, and so it should be utilized wherever possible. The importance of effective window treatment is discussed later.

## Glare Control

Ordinary measures should be taken to control glare from windows and electric light sources from shining into the eyes of the occupants or reflecting in computer screens, TVs, or shiny surfaces on workbenches or kitchen counters. Proper shielding of light fixtures and the provision of blinds that can flexibly control the sun and glare from windows are discussed in detail in the Design Team Strategies of the Lighting Manual. Firehouses contain a number of spaces where occupants may be prone, day and night. Dormitories and sitting rooms are areas when firefighters may sleep at night or recline or nap during other hours. In older firehouses, office spaces may double as the sleeping quarters for officers. In all these circumstances, the lighting should be fully shielded from occupants looking straight up. Indirect light from light coves, valances, or pendant fixtures should be the primary source. Any directional light sources such as downlights, accent lights or portable lamps should be used sparingly, be highly shielded, and be on separate switches or dimmers.

## Light Distribution on Surfaces

Light-colored, matte or semi-gloss room surfaces and furniture help to distribute the light uniformly and reduce shadows and light absorption. Even those rooms requiring complete darkness at night do not require dark walls. During the day, a dark-colored room will create glare from the windows due to the excessive brightness contrast. Luminance ratios should be close to uniform, that is, not exceeding a 1:5 ratio between average and maximum. In order to achieve the desired uniformity, reflectances should be high and finishes diffuse. Ceiling finishes should reflect a minimum of 80% of the light, including the apparatus room ceiling. All exposed structure, ducts, rails, shelving and storage should be painted white, or be brushed stainless steel. Consider royal blue or other colored floor mats in the fitness room, rather than black. Walls should be a minimum of 70% reflective generally, with 50-60% reflectivity acceptable below 30". Polished, glossy and shiny surfaces should be avoided, because specular reflections can reduce visibility and cause glare. The most matte finish available that will provide acceptable maintenance should be used. Specify eggshell or semi-gloss paints or tiles. Use heavily brushed metal surfaces. The use of color accents and color-tinted walls is desirable to reinforce the residential nature of the firehouse, and can be achieved within the reflectance recommendations above. Consider the use of a contrasting color band at the nosing of stair treads.

## Color Appearance and Color Rendering

Color appearance is somewhat important in firehouses. The natural appearance of people and objects is desirable in any residential setting, and tasks such as workbenches or decontamination require good color rendering. The FDNY requires that all firehouses use the same standard colors for consistency and ease of maintenance. The FDNY standard color for linear fluorescent lamps is 835, that is, a color rendering index (CRI) of 84+ and correlated color temperature (CCT) of 3500 Kelvin. This provides a good compromise between the nighttime residential functions and the cooler daylighted areas and industrial functions. For compact fluorescent lamps (CFL) shorter than 16", specify a 830 color (CRI of 80+ and CCT of 3000 Kelvin), which is slightly warmer than the linear fluorescents, because the CFL's tend to be used almost exclusively in the more residential spaces. For low wattage metal halide, specify a CRI of 70+ and a CCT of 3200 Kelvin. See the Sample Luminaire Schedule for full specifications.

## Light Levels

Since firehouses and other emergency facilities are typically occupied by employees who are also residents, it is not necessary to provide the higher light levels usually required for public spaces, where lighting is essential for safety, orientation or wayfinding. The uniform distribution of light is still important, and lights should be placed at crucial locations such as the tops of stairs, and intersections or changes of levels along the “path of response” leading to the trucks. Keep in mind that the “minimum” light level values listed below are also used as the basis of national and state energy codes. Exceeding the recommended minimum light levels will make it very difficult to meet the energy code limitations listed later.

### LIGHT LEVELS - RECOMMENDED AVERAGE MAINTAINED ILLUMINANCE, IN FOOTCANDLES (FC):

FUNCTION	MINIMUM HORIZONTAL FC	MINIMUM VERTICAL FC	FC ACHIEVED WITH TASK LIGHTS	COMMENTS	NOTES
Apparatus Room	30	5		Multiple levels of light	1
Decontamination	30				
Ambulance	-	-	50	Task lights to shine into rear of ambulance	2
Workbench	30		50	Local task lighting required	6
Housewatch	30		50	Local task lighting required	5
Offices	30	5	50	Local task lighting required	5
Training Room/ Study	30		50	Local task lighting required	5
Sitting Room	10		30	Local task lighting required	3
Dining	10	3	30	Local task lighting required. Daylight important.	4
Kitchen-general	30	5			4
Kitchen-critical	50	10		Includes undercabinet lights	4
Pantry	20	3			
Exercise Room	5-10			Daylight very important	
Dormitories, bunkrooms	5-10	3		Reading lights for Officers Bunkrooms	3
Toilets	5-10	3			6
Mirrors, for grooming	30	5			3
Showers	5-10	3			6
Locker rooms	5-10	3			6
Corridors	5				6
Stairs	5-10				6
Pole-Holes	5				
Storage/Gear Racks/Tools	10				6
Mechanical/electrical /pumps	5-10				

Values from IESNA Handbook, Ninth Edition, unless otherwise noted. 1.Values from IESNA Municipal Buildings – Fire Station category. 2.Values from IESNA Health Care category. 3 Values from IESNA Residential/Hotel category. 4.Values from IESNA Food Service category. 5.Values from IESNA Office/Reading category. 6.Values from other Design Briefs within this DDC Lighting Manual.

## DESIGN AND LAYOUT STRATEGIES

### All space types: Light Source (Lamp) Selection

For any firehouse project, use only linear fluorescent, compact fluorescent, metal halide and LED lamps, and limit the number of different lamp types and wattages. To the greatest extent possible, utilize 4' fluorescent T8 lamps. Specify the DDC-required T8, that is, a “super high-performance” and low-mercury type as described in the Lighting Technologies section of the Manual. Also specify the “extended-life” version of these fluorescent lamps to achieve at least 24,000-hour life, and preferably 30,000-hour life. Although instant start ballasts are preferred for most NYC applications due to energy efficiency, the frequent switching of lamps in firehouses favors the use of “programmed” rapid start ballasts to prevent shortened lamp life. Elsewhere in the interior, use compact fluorescent sources. Use LED lamps for Exit lights or for red/amber step lights if used. On the exterior, use Metal Halide lamps that are low wattage (under 150W), good color rendering (75+ CRI) and warm in color (3200 Kelvin).

### Apparatus Floor

Provide standard industrial fluorescent strips with slotted reflectors, aligned between the vehicles and the side walls, and between multiple vehicles. Specify luminaires with spring-loaded turret sockets to securely retain the lamps. Mount these luminaires slightly above the height of vehicles, (ideally 14' AFF) and coordinate the locations to avoid obstructions from overhead door tracks or exhaust extraction equipment. Provide more lamps or luminaires in those aisles with vehicles on both sides. Provide local task lighting under shelves at workbenches. For special activities like decontamination select fixtures that are sealed and gasketed, and can be sprayed with water or washed with a 10% bleach solution.



### Offices and Training Room

Design offices and training rooms so that the lighting is screened from the view of any sleeping area. See the Office Lighting Brief in this Manual for standard office lighting. If office desks are located within an officer's sleeping area (found in some older firehouses), use indirect office lighting or luminaires with no exposed lamps, supplemented by local task lighting. For the Housewatch, provide a two-level fluorescent system for the daytime and evenings, as well as local task lighting.

For ambulance bays, consider specifying a permanent rack of fluorescent lamps mounted vertically and located to shine into the back of an ambulance for cleaning and decontamination. Protect the lamps from breakage or liquids with cages and acrylic lenses. If a permanent arrangement is not practical, consider luminaires that drop from the ceiling, roll into position on a portable frame, or provide adjustable “loading dock” lights mounted to walls or ceiling. (See the Luminaire Schedule in Warehouse Brief for loading dock lights).

### Dormitory and Sitting Room

These rooms have several things in common. Firefighters use them for relaxing or sleeping and they require natural light during the day and total darkness at night. No exposed lamps or bright reflections should be visible from any viewing angle. The atmosphere should be comfortable, relaxed and residential. At certain times, there must be adequate light levels for cleaning, maintenance and localized task performance. Sitting rooms may be used for studying, recreation or sleeping, and require flexibility and multiple levels of control. The occupants may change the furniture or functions over time. Consider indirect lighting from coves and wall slots, or if ceiling heights are limited, consider recessed direct/indirect coffer fixtures (see the Sample Luminaire Schedule at the end of this Brief). Use fluorescent sources to create large areas of indirect lighting, and design for wide distribution and shielded downlights, table lamps, wall sconces, pendants, or torchieres. Specify opaque light shades in areas where bright glowing objects may disturb sleepers, or reflections of glowing lampshades may disrupt viewing of TV or computer screens. Specify dimming ballasts for fluorescent or compact fluorescent lamps. Consider extremely low-output red/amber step lights in dormitories and sitting rooms, and along the pathway between sleeping areas and toilet areas.

## Kitchen and Dining Area

Utilize natural daylight wherever and whenever it is available. Due to the large volume and frequency of cooking in a commercial kitchen environment, light fixtures should be selected that are easily cleaned and maintained. Consider recessed lensed fluorescent troffers over the counters, with fluorescent lensed task lights under the cabinets or shelves. Specify integral CFL lights within the smoke hood over the stove/grill. Wide-distribution light fixtures are preferable to narrow-distribution downlights, due to the need to see into upper cabinets and shelves. However, if possible, shield the view of the kitchen lighting from the dining area by using coves, baffles or valances. The dining area lighting should be flexible, capable of varying from the brighter conditions appropriate for breakfast, cleaning, or visually demanding projects, down to the lower illumination levels appropriate for dinner and quiet activities. The walls are often used for display, and CFL wall washers or accent lights should be considered.

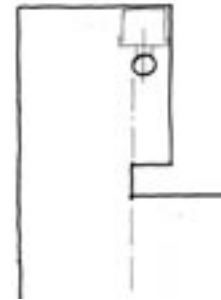

Detail of wall slot with lamp cut-off from view

## Fitness Room

Fitness rooms should be located on the building perimeter, maximizing daylight as the primary source of illuminations. Select luminaires that shield lamps from view, to avoid direct glare while lying prone on the mats or benches. Controls should prevent the use of electric lighting when natural light is adequate.

## Corridors

Refer to the Corridor and Stair Lighting Brief for typical lighting recommendations. In firehouses, the corridors often contain a large number of displays, bulletin boards, photos, plaques, and memorabilia. Consider luminaires that distribute most of their light to the walls rather than the floors. Corridors in firehouses are not required to comply with ADA standards, but common sense should be used in the selection and location of fixtures along the paths of response or egress.

## Toilets, Lockers, and Shower Rooms

Refer to the Toilet, Locker and Shower Lighting Brief for typical lighting recommendations – these are appropriate for firehouses and emergency services facilities. Utilize daylight to the greatest extent possible, and keep all finishes light in color, especially in the selection of lockers and toilet partitions. If possible, align rows of lockers perpendicular to the window wall to increase daylight penetration along the aisles.

## Exterior Lighting

Refer to the Exterior Lighting Brief for typical lighting recommendations – these are appropriate for firehouses and emergency services facilities. Also see specific FDNY requirements for specialized lighting.

### **SPECIAL FDNY CRITERIA FOR LIGHTING SYSTEMS FOR FIREHOUSES**

The Fire Department of New York has specific requirements for lighting, including alarm lights, pole-hole lighting, stair lighting, exterior red lanterns and lighting for emergency egress, exit signage and emergency power generation. See the FDNY Standards for Specialized Lighting for exact requirements.

## ENERGY EFFICIENCY STRATEGIES FOR FIREHOUSES

### Daylighting

To the greatest extent possible, strive to make daylight the primary source of light during the day. On the apparatus floor, consider skylights, clerestories and overhead doors as potential sources of daylight. For the best distribution and for privacy, glazing should be above the height of the vehicles and the exhaust extractor rails, and in the highest two or three panels of the overhead doors. Where privacy is of particular concern, use diffusing panels. If possible, the kitchen and dining rooms should have windows for both daylight and views, but the light from these windows should be shielded from the Sitting Room. If not, these windows may cause glare or disrupt TV viewing, causing the blinds in the kitchen or dining areas to be closed unnecessarily. The fitness room should have high levels of daylight for health and stimulation, but direct sun penetration, especially in the summer, should be controlled by exterior shading and/or interior blinds. In dormitories, windows are desirable for view, daylight and fresh air, but here well-functioning blackout shades will be required to achieve total interior darkness at night and on summer mornings. Rooms adjacent to the dormitory, such as locker rooms, toilets, or fitness rooms should be physically shielded by partitions or doors or interior blinds, to avoid light leaks. Locker rooms could also be lighted primarily by daylight, if space on the perimeter can be found for this function. Diffuse glazing should be considered for the lower panes of glass, where privacy is an issue, but left clear elsewhere.



Windows are desirable in dormitories, along with black-out shades

### Window Glazing and Treatment

To use daylight effectively and actually save energy, window treatments must be sturdy, commercial grade, and properly selected for the application. In some cases, more than one method of window control may be necessary. Overhangs, louvers, fins or awnings located outside the building will provide the best sun control and reduce summer heat gain. Even when exterior shading is used, interior blinds and shades will often still be required for additional sun control or glare reduction. Totally opaque black-out shades should be specified for dormitories, sitting areas and possibly training rooms. Note that blackout shades should not be black in color – they should be light colored, but impervious to direct sunlight. These shades or blinds should be heavy duty with chain operation, so they can be smoothly and repeatedly opened and closed. If they are not easily reachable because of height, furniture, stairways or other obstructions, provide motor operated control from a local switch. If privacy is an issue, use diffuse glazing only where necessary, or translucent shades that operate from the bottom up. It should not be necessary to block out all natural daylight in order to achieve privacy. Note that diffuse glass or translucent shades can be glary when the sun shines upon them, so large diffuse areas are not recommended. If the entire height of glass must be obscured in order to achieve privacy, then adjustable Venetian blinds, angled to optimize reflected light, should be used in lieu of shades or diffusing glass

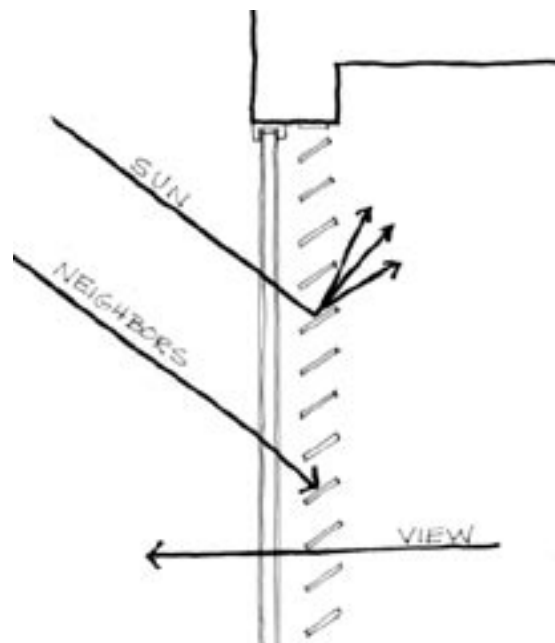

Optimal angle for Venetian blinds

## Surface reflectances

Wherever possible, use light colored walls, ceilings and furniture. Specify light colored lockers, shower curtains, toilet partitions, storage racks and kitchen shelving and appliances. This increases light effectiveness, saves energy, and creates a more comfortable visual environment.

## Task lighting

Localized tasklights not only save energy by reducing the requirement for ambient light, localized lighting also focuses attention and provides greater flexibility for different users and functions. In the apparatus room, provide task lights for workbenches. In the kitchen, provide supplemental lighting under the cabinets and within vent hoods. In sitting spaces, provide supplemental reading lights with integral dimmers and opaque shades so that some occupants can read without disturbing TV viewing or sleeping by others. If there is likely to be a focused activity in the middle of the space (card table, billiards, etc.,) provide downlights or pendants with a narrow distribution that can be turned off when not needed. In offices, study areas and training rooms, provide locally controlled desk lights or under-counter lights to supplement daylight or ambient lighting. Consider “articulated” task lights (allowing the adjustment of the fixture in two or three axes), mounted to desktops or walls. All officers’ bunkrooms should be equipped with recessed or wall-mounted reading lights. These can also be used in dormitories for reading/studying during the daytime if adequate quiet study space is not available elsewhere in the firehouse.

## Multiple Zones and Automatic Controls

Design a reasonable amount of flexibility into the lighting system, so that all the lights are not turned on in a room when a few would do. Design “layers” of light that can be used individually, or in combination for various times of days and functions. Use the most efficient sources (fluorescent) for indirect lighting, and LED sources for Exit signs or red/amber step lights if used. Use occupancy sensors wherever possible. Follow the guidelines below for lighting controls in various spaces.

## ENERGY CODES: WATTS / SQUARE FOOT BUDGETS

FUNCTION	ENERGY CONSERVATION CONSTRUCTION CODE OF NEW YORK STATE		ANSI/ASHRAE/IESNA STD.90.1		NOTES
	-2002	+/- 2007	-1999/2001	-2004	
Fire Station – Whole Building	-	1.0	-	-	1
Fire Station Engine Room (Apparatus Room)			0.9	0.8	3
Office-Enclosed	1.5	1.1	1.5	1.1	
Office-Open Plan	1.5	1.1	1.3	1.1	
Classroom/Lecture (Training)	1.6	1.4	1.6	1.4	
Lounge/Recreation (Sitting)	1.0	1.0	1.4	1.2	2
Exercise	1.1	0.9	1.1	0.9	
Dining Area	1.4	0.9	1.4	0.9	
Food Preparation	2.2	1.2	2.2	1.2	
Sleeping Quarters			1.1	0.3	3
Restrooms /support areas	0.8	0.9	1.0	0.9	
Corridors	0.8	0.9	0.7	0.5	
Stairs-Active	0.8	0.9	0.9	0.6	
Active Storage	1.0	0.8	1.1	0.8	
Inactive Storage			0.3	0.3	3
Electrical/Mechanical			1.3	1.5	3

1. ECCC NYS only lists a value for a Whole-Building firehouse in the 2007 revision—no value is listed for 2002. No whole-building value listed for Standard 90.1. 2. Sitting/Lounge value not specifically listed for ECCC NYS so value is from “other” category. 3.Only ANSI/ASHRAE/IESNA Standard 90.1 specifically lists these values—no values are listed for ECCC NYS.



## LIGHTING CONTROLS FOR FIREHOUSES

### General Issues

The energy codes require some type of automatic shut-off of lights in all spaces when they are not occupied, including the residential areas of firehouses. (Energy code exemptions for “living” or “dwelling” units do not apply to these space types) In firehouses, most spaces are only occupied part time, and flexibility is highly desirable because these spaces serve multiple occupants and diverse activities 24 hours a day. Therefore, occupancy sensors are the obvious control choice for many firehouse spaces, but they must be specified and located with care. Note that modern light systems allow occupancy sensors to be used with other control devices, such as photo-sensors and timers, with the whole system controlled logically. Thus, for example, one can use occupancy sensors and daylight harvesting together. Occupancy sensors that turn lights on automatically are only recommended in spaces that have no windows and no sleeping functions, such as stairs, corridors, storage rooms or showers. In most cases, occupancy sensors should be wired to require “manual-on” activation of the lights via a wall switch. This is essential in sleeping areas, sitting rooms, housewatch, and training rooms, where automatic activation of the lights would disturb sleepers or disrupt activities.

All lights in the firehouse except nightlights should be wired for automatic off so that lights are turned off when there is no occupancy or no activity for a given period. The delay period prior to turn-off is adjustable, ranging from 5 minutes to 30 minutes, as is the setting for sensitivity to motion. Specified sensor settings should be pre-set by the factory or calibrated at installation. Newer models of occupancy sensors are “self-learning” so they quickly adjust time delay and sensitivity to typical usage patterns. (See Lighting Technologies for more information.) If lights are turned off prematurely (when movement has been too subtle), the occupant has 15 seconds to wave a hand or make another large motion to turn the lights back on. If no motion occurs in this period, the lights must be turned back on manually, at the switch. Avoid ceiling fans in rooms with occupancy sensors. The Alarm Light circuit should be wired to a timer set for five (5) minutes, so that Alarm Lights go off throughout the building after the firefighters have left on a call. The Alarm Lights should also be wired to the emergency generator.

### Apparatus Floor Controls

Daylight should be a major source of light, allowing the occupants to move throughout the apparatus floor without the need for electric lighting during most daylight hours. Of course, daylighting only saves energy if the electric lights are turned off, which can be done automatically via timeclocks or photosensors. In addition to daylight controls, expect to have three to four separate lighting zones on the Apparatus floor. The Alarm Light zone activates approximately one-third of the lights and is controlled by wall switches and occupancy sensors with an override by housewatch. Consider controlling separately each row of lamps in two-lamp fixtures, in order to provide a more uniform distribution at reduced light levels. This requires that the overhead luminaires be specified with “in-line ballast wiring for two-level switching.” It may be desirable to control the row of luminaires nearest to the housewatch on a separate zone. Locate manual-on switches for some zones at entrances to the space. All lighting zones should be turned off automatically by occupancy sensors. For total coverage of the entire space, several infra-red occupancy sensors wired in series should be pendant- or wall-mounted about 10 feet above the floor, aimed at the aisles.

Finally, a very few luminaires, (no more than 1 per vehicle) located at the back of the apparatus room or in between vehicles should be on a nightlight circuit and fitted with emergency battery ballasts. Task lights at workbenches should be connected to a local timer switch, set to 30 minutes. Lights for decontamination or for maintaining or cleaning inside vehicles should also be on local timer switches, and preferably activated by an elbow or lever. Such switches should be sturdy and cleanable with a bleach solution. Refer to the FDNY Communications Standards (not Specialized Lighting) for the control of Alarm Lights in Housewatch.

## Offices and Training Room Controls

As discussed in the Office Lighting Brief, the ambient luminaires in offices within firehouses should be controlled by occupancy sensors designed for manual-on and automatic-off operation. This can be done with wall-box units in small rooms (under 120sf) as long as the occupant is visible from the wall sensor. For larger or obstructed rooms, provide a ceiling-mounted occupancy sensor designed for manual-on, auto-off operation, and provide a separate electronic toggle switch by the door to turn the lights on. Task lighting should have a local switch. If more than 100 watts of undercabinet lights are used in a room, connect them to a local switch with an integral two-hour timer. Use two-level switching or dimming controls in training rooms, for flexibility.



The Office Lighting Design Brief contains more details regarding lighting and controls in offices and multipurpose spaces

## Dormitory and Sitting Area Controls

Wire lights intended for different functions on separately switched zones. Ceiling-mounted occupancy sensors are a good choice for these rooms, coupled with manual-on wall switches. Select occupancy sensors specifically designed for manual-on operation, and specify relays or power packs with integral relays so that the same occupancy sensor can switch off more than one zone. The occupancy sensor should never be capable of turning lights on automatically in these areas – this would disturb sleepers. In rooms where firefighters may sleep at night, consider red/amber step lights on a separate timeclock circuit. Place the most efficient lamps and ambient luminaires on the Alarm Light circuit. This will provide the higher illumination levels and best color to promote alertness.

## Kitchen and Dining Area Controls

Circuit luminaires to separate lighting zones for separate activities, like overhead lighting, undercounter lights, etc. Utilize ceiling-mounted occupancy sensors with manual-on switches. Connect the smoke hood lights to a wall switch and occupancy sensor.



## Corridor Controls

See the Corridor and Stair Brief for typical lighting control recommendations. Provide 24-hour night lights in stairs and pole holes, and automatic on/off occupancy sensors for all internal corridors. If red step-lights are provided in corridors leading to toilet rooms, wire the overhead lights in these specific corridors so that occupancy sensors are on time clocks, and will not turn on these lights automatically during specific sleeping hours. Alarm Lights and Emergency Lights will always override all other controls.

## Toilets, Locker Room and Shower Room Controls

See the Toilet, Locker Room and Shower Design Brief for typical lighting control recommendations – these are generally appropriate for firehouses and emergency services facilities. In toilet rooms, consider red or red/amber lights downlights on a special nighttime circuit, activated by a wall switch with a pilot light. Use manual-on switches for occupancy sensors in toilets closest to sleeping areas, so occupant can choose red light or fluorescent ambient light.

## Exterior Lighting Controls

See the Exterior Lighting Brief for typical lighting control recommendations. Provide multiple zones of exterior light for greatest flexibility. Only the red identity lights and lights on the flag should remain on throughout the night. Be extremely sensitive to neighbors when selecting and controlling exterior lights. Place exterior lights on motion sensors for the front door if vandalism or break-ins are an issue, or control them by timeclocks. Note that Metal Halide lamps are not suitable for motion-sensor activation due to their need to warm-up to full intensity. Where appropriate, connect the exterior lights adjacent to the apparatus floor's garage doors to the Alarm Light circuit.

## OPERATIONS AND MAINTENANCE STRATEGIES

### Specify with maintenance in mind

Provide “specification-grade” commercial lighting equipment that is sturdy, well made and easy to maintain and purchase. At the same time, avoid creating an industrial atmosphere in living spaces. Specify 10% spare lamps, and 5% spare ballasts, switches, power packs and occupancy sensors. Spares should be kept on-site, to avoid repair delays due to the City ordering process. Keep the number of lamp types to a minimum. Minimize the number of ballasts used by tandem-wiring whenever practical. Use 4’ T8 fluorescent lamps to the greatest extent possible. If 2’ lamps are introduced, use the same lamp type for all fixtures where that length is desirable. Use compact fluorescent lamps in lieu of incandescent, halogen or low voltage, to the greatest extent. Specify dimming ballasts for fluorescent or compact fluorescent lamps where appropriate. Specify that the contractor assemble and provide copies of the specifications and a maintenance and operation manual for all lighting components, and provide training videos.

### Design layouts with maintenance in mind

Avoid locating light fixtures in places that are difficult to access, such as over pole-holes or stair treads. Modern lamps no longer have single-pin bases or screw bases that can be manipulated from the floor with a pole – they require two hands and a securely balanced worker. Locate stair lighting at landings, and all other lighting within easy reach or where ladders can be safely located. Keep in mind that a fire alarm can occur while a ladder is in place.



### User’s manual

Firefighters do much of their own regular maintenance, and may even undertake repairs, so they should be well informed. There should be at least one copy of a comprehensive lighting maintenance manual given to the occupants, including a list of all lamp ordering codes, as well as installation and trouble-shooting guides for all luminaires and lighting controls. Involve the occupants in the contractor’s training sessions for all lighting controls, and provide them with training video-tapes. See the DDC website for specific specification language regarding commissioning and operations and maintenance manuals. In addition to the information provided by the original contractor, a brief description of the special lighting and energy-conserving features, and the correct usage of window blinds would be a useful tool for the occupants. A copy of this Firehouse Lighting Design Brief may provide the occupants with some insights, but a “design intent” description tailored to the specific project would be most useful.



### Dirt depreciation

Lamps and luminaires in the apparatus room, kitchen and showers will accumulate dirt more rapidly than in other spaces. These should be cleaned at least every six months to maintain an adequate lumen output.

### Calibration

In addition to the customary testing of lighting and calibration of lighting controls, it is important to verify the operation of the blinds prior to occupancy, to ensure easy and reliable daily use.

For reduced energy consumption, the following four-foot long fluorescent lamps are the DDC and FDNY standard: 32 Watt T8, 3,100 lumen, CRI 85+, 3500 Kelvin, low mercury, extended life (24,000 – 30,000 hours). Note that DCAS (NYC Department of Citywide Services) will have available one of the following lamps: GE #F32T8 XL SPX35 HLEC (10326); Philips #F32T8/ADV/835/ALTO (13988-1); Osram/Sylvania #FO32/835/XPS/ECO (21697).

## SAMPLE LUMINAIRE SCHEDULE FOR FIREHOUSES

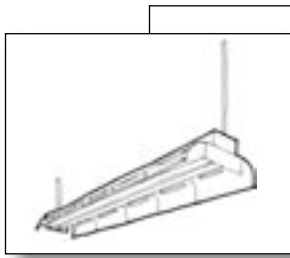

### PENDANT FLUORESCENT INDUSTRIAL LUMINAIRE WITH SLOTTED REFLECTOR

**Location:** Apparatus Room  
**Lamps in profile:** (2) 32W, High-Performance T8, 835 color, extended life, low mercury.  
**Description:** Pendant-mounted fluorescent luminaire in lengths of 4'-0" to 12'-0" using 4' lamps only. White baked enamel housing and reflector, slotted for 10% uplight. Heavy-duty lampholder end brackets with spring-loaded turret sockets for safe lamp retention. In-line ballast wiring for control of each row of lamps independently as required. Minimum 92% efficiency. Electronic programmed-start, multi-lamp ballasts. Emergency ballasts where indicated.

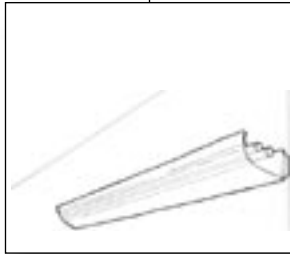

### FLUORESCENT WALL-MOUNTED INDIRECT COVE

**Location:** Dormitories, sitting, training  
**Lamps in profile:** (1) or (2) 32W, High-Performance T8, 835 color, extended life, low mercury.  
**Description:** Surface-mounted fluorescent luminaire in lengths of 4'-0", 8'-0" or 12'-0" using 4' lamps only. Baked enamel housing, white or light colored exterior to match wall. Totally indirect or less than 5% glow. Minimum fixture efficiency X%. Electronic programmed-start, multi-lamp ballasts. In-line wiring for control of each row of lamps independently, or fluorescent electronic dimming ballasts. Emergency ballasts where indicated.

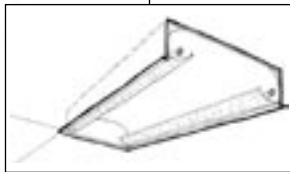

### FLUORESCENT RECESSED DIRECT/INDIRECT COFFER

**Location:** Training, Exercise, Dining, Dormitories, Office (also see Office Brief)  
**Lamps in profile:** (2) 32W, High-Performance T8, 835 color, extended life, low mercury.  
**Description:** Recessed 2' x 4' or 1' x 4' fluorescent luminaire with concave coffer and glowing side- or center-cove, lighting up into coffer. White baked enamel housing. Maximum 10% glow. Minimum fixture efficiency X%. Electronic programmed-start, multi-lamp ballasts. Emergency ballasts where indicated.

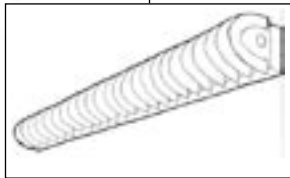

### FLUORESCENT WALL LUMINAIRE WITH RADIAL BAFFLES

**Location:** Corridors  
**Lamps in profile:** (1) 32W, High-Performance T8, 835 color, extended life, low mercury.  
**Description:** 4'-0" long wall-mounted fluorescent White painted radial baffles. If luminaire extends more than 4" into corridor, mount bottom of fixture at 6'-8" to meet ADA requirements for egress corridors. Electronic programmed-start ballasts. Emergency ballasts where indicated.

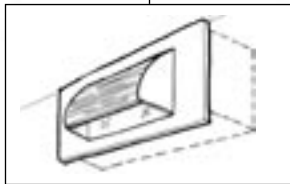

### RECESSED SHIELDED RED/AMBER STEP LIGHTS

**Location:** Dormitories, Sitting, Corridors to Toilets. (step lights are optional)  
**Lamps:** Red or amber LEDs (extremely low output in dormitories)  
**Description:** Step light with red colored LED lamps. Hood or louvers to shield view of lens. Prismatic or frosted lens to widen distribution. Red source for lighting path from dormitory to toilets. Wall-recessed, prismatic lens or louver. 120v integral ballast. Mount about 12" above the floor. Avoid mounting near head of beds.

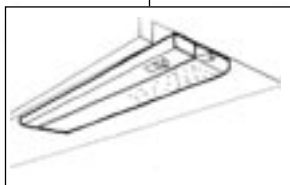

### UNDERSHELF FLUORESCENT TASKLIGHT

**Location:** Workbench, kitchen  
**Lamps in profile:** (1) 32W, High-Performance T8, 835 color, extended life, low mercury.  
**Description:** Linear fluorescent tasklight mounted under shelf or cabinets. Clear prismatic acrylic diffuser. Mount at front edge of cabinet, with lip to hide lens brightness. Orient so that acrylic diffuser aims at back wall.

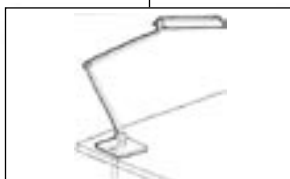

### FLUORESCENT ARTICULATED READING LIGHT

**Location:** Wall mounted or desktop. Sitting, Study, Training, Dormitories, Officer's bunk.  
**Lamps:** (1) 13W, CFL, 830 color  
**Description:** Wall-mounted or desktop reading light, with opaque shade, and articulated arms allow adjustment in three planes. compact fluorescent. Integral 120v ballast. A maximum range of 24" above the desktop. Weighted base, grommet-mount or clamp-mounted to desktop.

## LABORATORIES LIGHTING DESIGN BRIEF

The NYC Department of Design and Construction (DDC) manages the construction and renovation of NYC's municipal buildings, including those associated with the NYC Department of Health. Specifically these guidelines relate to public health laboratories meeting Biological Safety Levels (BSL) 1, 2 and 3 criteria. These guidelines are also applicable to laboratories in educational or healthcare facilities, or health clinics citywide.

Laboratory work is intensive and demanding, so the quality of light is an essential element for a healthy, productive and safe environment. While HVAC is by far the largest energy user in a lab, the Department of Energy estimates that lighting can still consume between 8% and 25% of the total<sup>1</sup>. Even more energy is consumed when the cooling loads due to lighting are included. Heat gain is a serious concern in laboratories, especially when the workers wear protective clothing, which can be fairly hot. Efficient lighting systems not only consume less energy, they add less heat to the space, reducing the need for, and energy consumed by of air conditioning.

This document is a chapter of DDC's Manual for Quality, Energy Efficient Lighting. The Manual discusses the basic issues of lighting quality, design process, lighting technologies, energy codes and includes references and glossary. Of particular relevance to laboratory lighting are discussions of the importance of early team involvement, daylighting controls, interactive design, mockups, and commissioning. In addition, the lighting Design Briefs on the topics of Offices, Corridors and Stairs, and Toilets, Lockers and Showers are applicable to many areas in laboratory buildings. Due to the highly specialized nature of public health labs, a Laboratory Consultant will typically be a primary member of the design team. Daylighting expertise will also be needed. Early discussions establishing laboratory criteria should involve the entire design team, to promote integration and improve the quality and sustainability of the project.



photo: Don Prowler & Associates, courtesy NREL

Daylighted labs at the National Institutes of Health

### Biological Safety Level (BSL) Descriptions

**BSL-1** Biological agents not likely to cause disease in healthy human adults.

**BSL-2** Biological agents that can cause non-life-threatening human disease through contact, ingestion, inhalation or inoculation. Access may be controlled, work must be supervised, and wastes must be decontaminated,

**BSL-3** Biological agents that can cause serious or lethal effects in humans through contact or aerosol transmission. Access is controlled, work is performed in biological safety cabinets (BSC), and air is not re-circulated. Special protective clothing is required and decontamination of room surfaces, equipment and waste is required.

**BSL-4** High-risk biological agents can cause life-threatening disease with easy or unknown means of transmission. Workers must wear full protective pressure suites ventilated by life support systems. Work is performed in Class 3 safety cabinets.

See Reference 2

The recommendations herein focus on two categories: Bio Safety Level 2, and Bio Safety Level 3, which each have different requirements. (See box for definitions.) BSL-2 has become the baseline level in new public health labs, since these spaces can be used for less rigorous BSL-1 activities. The highest risk BSL-4 laboratories are not within the purview of the DDC, but a few comments are included herein. Many of the differences between the four bio-safety levels relate to HVAC, protective gear, and waste control, rather than lighting. In BSL-3 and 4 labs, the luminaires must not allow air to pass into the ceiling plenum or walls, and must be able to withstand decontamination cleaning. Luminaires are decontaminated on occasion in a BSL-2 lab, but on a regular basis in a BSL-3 lab.

## LABORATORIES - SPECIFIC LIGHTING QUALITY ISSUES

ISSUE	IMPORTANCE
Color Rendering and Appearance	Very Important
Daylighting Integration and Control	Very Important
Direct /Reflected Glare	Very Important
Flicker	Very Important
Luminance of Room Surfaces	Very Important
Appearance of Space and Luminaires	Important
Light Distribution on Surfaces	Important
Modeling of Faces or Objects	Important

Chart adapted from IESNA Lighting Handbook, 9th Edition, from the category of Health Care Facilities-Laboratories. Priorities may vary for specialty labs.

### Color Rendering and Appearance

Color will be more critical for some lab work than others, but all lab areas should use excellent color rendering lamps. Specify fluorescent lamps with the DDC standard color of 835, that is, a CRI of 80+, and a correlated color temperature of 3500. For purposes of consistent color rendition as well as maintenance, the same lamp color should be used throughout the lab, and specified for the task lighting and safety cabinets.

### Daylighting Integration and Control

Windows and a connection to the out-of-doors are highly valued for laboratory workers, and daylighting can provide a valuable and energy efficient source of light. Daylighting design expertise is required to effectively utilize daylight while meeting the special concerns for labs, namely control of direct sunlight, uniformity of light, maintenance, and cleaning. Perimeter windows are not usually practical in BSL-3 and BSL-4 labs, due to the need for decontamination, total air seals, and security. In these cases, visual access to the outdoors can be achieved by visually connecting the labs to windows in adjacent spaces, via an interior glass barrier. Daylighting is highly recommended by the “Laboratories for the 21st Century”<sup>3</sup> program and has been successfully used in many health labs, including those of the National Institute of Health (NIH)<sup>4</sup>.



photo: courtesy Croxton Collaborative Architects and Health, Education + Research Associates, Inc.

The row of lights closest to the windows is continuously dimmed in response to daylight. All lights are controlled by occupancy sensors

### Flicker

Lamp flicker can be a serious distraction in a laboratory environment. High-frequency electronic ballasts, which are now standard, prevent fluorescent or metal halide sources from flickering and should be specified for new installations. Existing magnetic ballasts in older fume hoods and fixtures should be replaced with electronic ballasts. See Lighting Technologies in the Manual.

### Luminance of Room Surfaces

Laboratory tasks can be extremely visually demanding, so uniform luminance ratios are essential for visual performance. Luminance ratios should be close to uniform, ideally not exceeding 1:3 ratio between average and maximum or 3:1 ratio between minimum and average at any surface within view while performing the task. The task should typically have the highest luminance in the field of view. Light-colored room finishes are essential to achieving acceptable luminance ratios – see section on Reflectances and Finishes below.

## Glare – Direct and Reflected

Certain laboratory tasks require more glare control than others. Lab workers may look up to evaluate specimens or read measurements, so they will be more susceptible to glare from overly bright reflectors or visible lamps. Direct or reflected glare that affects the lab worker's ability to perform tasks will be counterproductive or even hazardous in such environments. Whenever possible utilize luminaires with good glare control (shielding of the light above 45 degrees) and avoid bright lamps (T5, T5HO) overhead in open-bottomed luminaires. Up-lighting the ceiling is a good strategy since it reduces the contrast from bright luminaires and softens shadows. Due to the use of glass and polished materials, the tasks in laboratories are subject to “veiling reflections” a form of reflected glare that obscures the task detail. The combination of uniform ambient lighting and articulated task lights that are adjustable in several planes will give the lab worker options to avoid glare. For safety and accuracy, shadows should be avoided in laboratories, unless intentionally created by local task lighting to achieve a “grazing” angle of light.

## Appearance of Space and Luminaires

Laboratories can be visually chaotic, so the lighting should be as organized as possible to avoid adding to the chaos. Use a small family of luminaire types, arranged in a harmonious way. While the luminaire options are limited for BSL-3 and 4 labs, a wide range of attractive luminaires and beautiful lighting designs are possible within BSL-2 criteria.

## Light Distribution on Surfaces

Adequate light should be directed at all the surfaces in a lab, to create a comfortable and uniformly luminous environment, and to provide functional lighting for three-dimensional tasks and the vertical shelving. The more directions the light comes from, the more comfortable and effective the lighting will be. Improving the lighting quality reduces the need for high illumination levels.

## Reflectances and Finishes

In order to achieve the desired luminance ratios and uniformity, reflectances should be high and finishes should be matte. Ceilings should be a minimum of 80% reflectance (90% preferred). If suspended ceilings are not used, the slab, structure and ductwork should be painted white. Walls should be a minimum of 70% reflective, equipment and countertops at least 60% reflective, and floors not less than 20% reflective (preferably higher). Epoxy resin lab benchtops are now available in finishes other than the traditional black. The lightest color available is desirable for visual comfort and energy conservation, and should be specified unless most of the tasks specifically required a dark background. When a dark background is only required in specific areas, limit its use to those surfaces. If a dark background is only required at certain times, provide a portable dark surface that can be used for contrast. Polished, glossy and shiny surfaces should be avoided, because specular reflections can reduce visibility and be distracting. Specify stainless steel surfaces with a brushed or satin finish rather than a shiny finish whenever possible. The most matte finish available that is acceptable for cleaning and maintenance should be used. Typically, use eggshell paints for BSL-2 or semi-gloss paints for BSL-3 labs. Ensure that all surfaces are suitable for cleaning with decontamination chemicals, typically a 10% bleach solution.

## Modeling of Faces or Objects

For some tasks in laboratories, the ability to see three-dimensional form or texture makes visual performance easier. Modeling is enhanced by an increase in directional light in relation to totally diffuse light. Local task lighting combined with uniform ambient lighting is the most effective way to provide adequate definition of three-dimensional form. Lights that are adjustable in position and in the control of the lab worker are preferred.

## LIGHTING LEVELS

Some tasks in laboratories may require light levels as high as 100 footcandles or above, but this is not needed at all times or in all locations. The ambient lighting system should be uniformly distributed. Consider providing two levels of illumination (say 25 fc and 50 fc) on the benches, and supplemental task lighting for the benchtops where higher light levels are needed. Task lighting strategies are discussed later.

High light levels can be problematical for several reasons: heat gain, energy consumption in excess of code, excessive contrast and even difficulties performing tasks, such as viewing computer screens. Improved lighting quality and glare control improves visibility, thereby reducing the need for high illumination. The Illumination levels recommended by the Illuminating Engineering Society of North America (below) were used to develop the watts/sf limits inherent in most national and state energy codes. Consequently, it will be difficult to meet the NYS Energy Code values (listed later) if the illuminance levels greatly exceed those recommended below, or high illumination levels are provided throughout, rather than locally. The Illuminating Engineering Society of North America does not list recommended ambient light levels for laboratories – only for specific tasks that may occur in a lab. It is recommended that luminaires placed relatively close to the task provide illuminance values above 30 footcandles. Note that multiple sources of light – daylight, ambient and task lights – all add up to provide the total illuminance on the task.

### LIGHT LEVELS (RECOMMENDED MAINTAINED ILLUMINANCE, IN FOOTCANDLES (FC)):

FUNCTION	HORIZONTAL FC	VERTICAL FC	NOTES
Lab general and computer use: Performance of visual tasks of high contrast and large size.	30	5-10	
Gown and de-gown inspection, specimen collecting and performance of visual tasks of high contrast and small size, or low contrast and large size.	50	10	1
Performance of visual tasks of low contrast and small size.	75-100		1

Values from the IESNA Lighting Handbook, Ninth Edition, Figure 10-9, Determination of Illuminance Categories.

1) Light levels on the task, not the room in general.

## SPECIAL LABORATORY DESIGN CONSIDERATIONS

### Ceiling-Recessed Luminaires

Recessed luminaires do not provide desirable light to the ceiling, and should be avoided in laboratories, unless very low ceilings prohibit the use of pendant direct/indirect luminaires. (See Light Distribution and Luminaires in the Design and Layout Section that follows.) Also, floors, walls, ceilings, doors and windows are all part of the “secondary barrier” of biosafety protection (the “primary barriers” being procedures and clothing). Consequently, any luminaires recessed into these surfaces become part of the barrier, and have to meet stringent criteria. In BSL-2 labs, standard luminaires recessed in BSL-2 must prevent room air from returning into the ceiling plenum. If a client requires a fully sealed ceiling assembly in a BSL-2 lab, and the ceilings are too low for a pendant direct/indirect luminaire, use a surface-mounted luminaire with good shielding. BSL-3 labs typically require specialized sealed and gasketed luminaires, recessed or surface-mounted to the sealed ceiling. Unfortunately, the flat, sealed lenses lack glare control and the sealed housings increase the luminaire cost.



## Clean Room Luminaires

Clean rooms are not the same as bio-safety rooms, and are not typically found in bio-labs. They are mentioned here because luminaires are not manufactured specifically for biosafety levels, but several manufacturers make luminaires rated for “Clean Rooms” which meet the criteria for BSL-3 labs. Clean Rooms are designed to protect the room’s contents from micro-contamination from lab workers and the environment

### Clean Room Classification of Luminaires:

A Clean Room “Class 100” rating means, (among other criteria<sup>5</sup>) that no more than 100 particles larger than 0.5 microns are present in any given cubic foot of air. A Class 10 rating would limit the number of particles to 10. Class 1 is the most stringent, and is typically provided in special enclosed cubicles or laminar flow cabinets. Although Federal Standard 209E establishes the classification of Clean Rooms, literature provided by luminaire manufactures often refer to “IES” Class 10, 100, 1000, 10000 ratings. In this case, IES refers to the Institute of Environmental Science and Technology, not the Illuminating Engineering Society.

outside the lab, while biosafety labs are designed to protect lab workers and the environment outside the lab from potentially harmful agents coming from the labs. Both require a tightly sealed room, personnel protective gear, sophisticated air-handling and regular decontamination. There seems to be no direct correlation between Clean Room and BSL criteria, so discuss criteria with the client and Lab Consultant before specifying luminaires. Since there are cost and lighting quality tradeoffs with using Clean Room luminaires, they should not be specified if not absolutely needed.

### Luminaire construction

To ensure that the air from biosafety laboratories does not contaminate any other parts of the building, laboratory spaces are typically “negatively pressurized, so any air exchange between adjacent spaces always moves in the direction of the cleaner rooms into the laboratory 2.” Labs are supplied with fresh or filtered air, all exhaust air is ducted out of the space rather than returned through the plenum, and no room air is allowed to leave the room by moving through luminaires into the plenum. All recessed luminaires in labs must be specified as “static” rather than “air return”. In the case of BSL-3 and -4 labs, the spaces are not only sealed off from all adjacent rooms, but all air that leaves the labs is filtered and exhausted

from the building -- never re-circulated. Recessed luminaires in BSL-3 and -4 spaces must be sealed and “triple gasketed”. This means there must be continuous gasket in three locations: between the housing and the ceiling, between the doorframe and the housing, and between the lens and the doorframe. In BSL-4 spaces, luminaires cannot have doorframes on the room side, because lamps must not be accessible from within the lab space. BSL-4 luminaires must be top-accessible from the interstitial space above the ceiling, and be suitable for installation into a membrane ceiling system. An Ingress Protection (IP) rating of IP-65, is recommended for luminaires in BSL-3 labs and required in BSL-4 labs (see box).

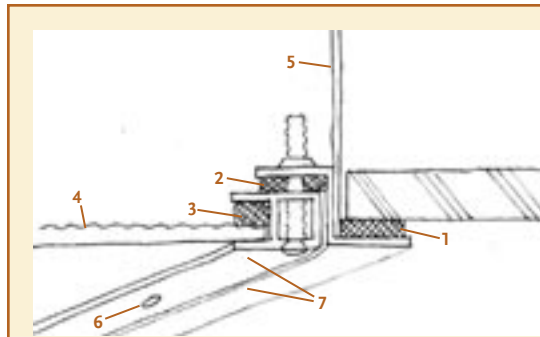

### Example of “Triple Gasketing”

1. Continuous gasket between ceiling and frame. Micro-cellular.
2. Continuous gasket between door and housing.
3. Continuous gasket between doorframe and lens
4. Lens with smooth side facing room.
5. One-piece sealed housing.
6. Counter-sunk captive screws on regular spacing to create continuous seal.
7. Stainless steel housing and door. Crevice free.

decontamination solvents, but the housing should be aluminum base rather than cold rolled steel. Stainless steel or painted stainless steel is the standard for BSL-3 and BSL-4 labs, along with a crevice-free design to maintain cleanliness. Bacteria-resistant paint with a silver ion technology (brand name AgION) is gaining use in medical and laboratory spaces for all metal surfaces like door handles, faucets and luminaires. It requires a baked-on application, and is available in clear, white and colored finishes, with anti-

microbial action that will last the life of the object that is coated. Luminaires are available with this finish from several manufacturers of Clean Room lighting products. Luminaires selected for BSL-1 and BSL-2 labs should be relatively easy to clean. Pendant direct/indirect luminaires with baffles below generally stay cleaner because the open top and bottom provide fewer horizontal surfaces on which particles can settle. Materials like perforated metal are harder to clean and are not recommended, even in BSL-2 labs.

### Light sources

Even when a daylighting strategy is being pursued, electric light sources will be required. Fluorescent lamps are the best electric light choice for laboratories for several reasons. They are the most efficient sources, providing the most illumination for the least wattage and heat. They are suitable for taller spaces, allow greater switching flexibility than metal halide, and instantly relight in case of power loss. The high performance T8 lamps described in the Lighting Technologies section offer excellent color rendering (85+ CRI) and extended long life (up to 30,000 hours). Electronic ballasts eliminate flicker and hum, and fluorescent lamps are appropriate for multiple-level switching and continuous dimming. 4' long T8s are the most efficient, so 3' and 2' long lamps should be avoided or limited to task lighting. Compact fluorescent lamps are not as efficient as linear lamps, but use far less watts than any form of incandescent, halogen, xenon or LEDs. Two T5 lamps may be the only viable choice in fixtures integral to fume hoods or safety cabinets if higher light levels are required than can be obtained with a single T8 lamp. High output T5HO lamps are less energy efficient than T8s or standard output T5, and problems have been found with dimming some T5HO lamps. Replacing two T8s with a T5HO in pendant luminaires may reduce material use, but also eliminates multiple switching options. Minimize the number of lamp types used in the building, and try to use the same color for all lamps of the same size, with 3500 degrees recommended for the T8's.

#### Ingress Protection (IP) Rating

The IP rating is a two number system – the first is related to dust penetration (6 is the highest, denoting “dust tight”) and the second number relates to moisture penetration (5 protects against the ingress of water from “jetting”). The latter allows lab fixtures to be hosed off for cleaning.

### Thermal issues

Heat gain is a serious concern in laboratories, especially in BSL-3 and -4 labs where 100% of the conditioned air is exhausted, and lab workers are garbed in protective layers that tend to make them hot. The most efficient lamp/ballast combination emits the least heat to the space, and requires less cooling. When attaching task lighting under shelves, a thermal separation may be required to keep the luminaire heat from affecting the reagents on the shelf above.

### Transparency

In many labs, internal glazing is encouraged between the laboratories and adjacent spaces. This may be for supervision, security, communication, verification of the “chain of possession” of legal evidence, access to natural light and views, a greater sense of openness, or other reasons. Care should be taken to design a transition between lighting systems that is harmonious and color consistent, and to control glare from windows or adjacent luminaires. Preferred luminance ratios are a function of the lighting within the field-of-view of the lab worker, whether or not the source is physically within the laboratory space.

### Balancing technical and quality considerations

Laboratory design requirements sometimes presents conflicting lighting criteria. In BSL-3 and -4 labs, safety is going to override many considerations for lighting quality. For example, glare criteria may be hard to achieve in BSL-3 and -4 labs, because baffles and louvers that control glare provide too many surfaces that are difficult to decontaminate. In BSL-1 and -2 labs, a balance should be sought between lighting quality issues and decontamination or maintenance concerns. Windows provide high quality lighting and create a more cheerful working environment, but the normally desirable aspects of daylight, such as dynamic changes in intensity and color, may need to be suppressed for certain lab activities. Once again, the client and designers should strive to optimize the positive qualities of view and natural light with the functional requirements of the work. Both can contribute to a safe and productive work environment.

## DESIGN AND LAYOUT STRATEGIES

### Daylighting

Lighting levels should remain relatively constant for most functions in laboratory spaces, so, for laboratories with daylighting, continuous photosensor dimming systems are recommended. No direct sunlight should ever be allowed to hit the workbenches or sensitive materials in a lab space, and even sunlight re-directed to the ceiling may create unacceptable luminance ratios. Side-lighting from windows is preferable because of the view, but north facing monitors (i.e., a sawtooth roof) can provide uniform light levels and save considerable energy for laboratories located on the top floor. Laboratory windows are often specified with triple glazing or protective impact-resistant layers. The visible light transmission (VLT) of the overall glazing assembly should be obtained from the Architect for the calculations.

Separating windows that provide view from those that provide daylight is an effective strategy to enhance the depth and uniformity of the daylight's distribution. Light shelves increase this effect, while also controlling direct sun penetration and sky glare. Light shelves should be located between upper windows dedicated to daylighting with higher visual light transmission (VLT), and lower windows used for views, with a lower VLT. They shield the lower windows from the sun, and the top surfaces serve as reflectors which bounce daylight from the upper windows off the ceilings inside. Light shelves are more thermally effective when located on the outside of buildings, and this location also eliminates the need to decontaminate them. The top of a light shelf should be light colored, but not mirrored. Manually operated blinds or shades should be provided for the lower windows. Special window units are available with integral blinds, avoiding dirt buildup or contamination inside the lab. If the window orientation is not true north or south, (as is common in NYC), blinds may also be required at the upper, daylight windows to prevent direct sun penetration during a few hours of low sun angles. If sun blocking is required for the upper windows, provide automated motor controls activated by photosensors, to maximize the use of daylight when sun penetration is not a problem. For more daylighting information, see Design Team Strategies in the Manual and the Daylighting for Labs - Best Practices 3 guide from the Laboratories for the 21st Century program.

### Layouts

There is no optimum lighting design for a laboratory. Bench layout, ceiling height, room geometry, functions, and budget can vary widely. The following comments are offered for the consideration of the designers, but are not intended as prescriptive solutions. The placement of office workstations and charting areas next to the windows can provide an effective transitional area for daylight and preventing sun penetration into the lab benches, while still providing view and openness. Although it is more costly, providing more luminaires, with fewer lamps in each, results in better luminous quality and more opportunities for energy saving control strategies.

### Light Distribution and Luminaires

Although totally indirect lighting can be flat and uninteresting, like an overcast sky, some indirect lighting is desirable to create a more comfortable and productive work environment. For BSL-1 and -2 labs there are many choices for lighting equipment, so high standards of comfort, lighting quality and energy efficiency can be achieved. One very good quality, energy efficient solution is the use of a linear bi-directional pendant with direct and indirect lighting located above the edge of, and parallel to the benchtop. (See the Sample Luminaire Schedule for Laboratories, at the end of this Design Brief.) This distributes light to the ceiling and vertical surfaces, and provides higher illumination because it is mounted closer to the task surface. Straight cross-baffles on the bottom opening offer adequate glare control and are easier to decontaminate than parabolic cross baffles.

The least recommended solutions are ceiling mounted parabolic or lensed troffers that direct their light downward. The luminaires may be less expensive, but their installation may be costlier, and they provide the lowest quality of light, due to shadows, overhead glare and lack of indirect light. Parabolic louvers reduce glare only from some angles of view, and should be painted white or brushed natural aluminum rather than specular (shiny). Totally indirect fixtures provide the least glare, but also the lowest light levels. They must be coupled with extensive task lighting to meet the energy codes as well as the light level requirements. Lighting the walls, ceiling and benchtops does not need to be accomplished with a single luminaire type. Depending on the application, two or three luminaire types might provide the most productive and energy efficient solu-

tion for a laboratory. In BSL-3 and -4 labs, luminaires have sealed lenses which diffuse the lamp brightness, but do little else to control glare. “Fisheye” or “batwing” lenses are preferred to typical prismatic lenses for their lower surface brightness.

### Layouts and Orientation (Labs and Luminaires)

Locating lab spaces on the north side of a building will provide the most uniform daylighting levels, the least danger of direct sun penetration, and less solar heat gain to the labs. Locating the benches perpendicular to the window walls will reduce glare and allow for a deeper penetration of the daylight into the space. In most daylighted spaces, a more natural transition between natural light and electric light will be achieved if the luminaires are running parallel to the window wall. In labs, the orientation of the luminaires perpendicular or parallel to the benchtops is an equally important consideration. If benches are fixed, running the luminaires parallel to the bench has been described as an effective solution. Locating a single row of pendant fixtures in the aisles between two rows of benches has gained popularity. It is more economical due to the reduced number of fixtures, and can provide acceptable quality in spaces 9'-6" or higher. It also distributes the light deeper under the bottom shelf. To prevent a situation where the lab worker casts a shadow on his/her own task, mount the bottom of the single row luminaire at 8'-0" or higher, with at least a 60% upright distribution and a 90% reflectance ceiling.



courtesy: LAM Partners Inc. and Litecontrol

Luminaires over benches

Moveable benches are required in some laboratories, but this flexibility creates new design challenges. If benches or even aisles are not fixed in plan, one efficient solution is to attach ambient lights to the top shelf of the bench units, with wireless lighting controls. Ceiling or pendant luminaires will be less efficient due to the absorption of light by obstructing shelving units. Lighting the ceiling becomes even more important in flexible labs. Direct luminaires should not be used in flexible spaces because of the shadows they create. Study the angle of view in front of a worker to the luminaires over the next rows of benches to determine potential glare conditions before finalizing luminaires or their locations.



courtesy: LAM Partners Inc. and Litecontrol

Luminaires centered in aisle

### Obstructions and spacing criteria

When performing lighting level calculations, the shelving units between benchtops must be taken into consideration, as these will absorb much of the lighting. The “spacing criterion” provided in manufacturers’ literature is based on open spaces, and are not relevant to an obstructed space like a lab. The “room cavity ratio” (RCR) used in “coefficient of utilization” (CU) charts should also be adjusted for laboratory spaces. For preliminary lumen method calculations, an “obstruction factor” of 0.70 may be used in lieu of modifying the CU value. (See the Glossary and Lighting Technologies in the Manual).

### Task Lighting

Locating luminaires nearer to the task will provide many benefits, reserving high light levels for only those locations and times where they are needed -- achieving high illumination levels for the lowest wattage, and allowing consumption to be controlled by the individual lab worker. This strategy may also be the only way to provide the highest lighting levels for difficult visual activities and still meet the energy code. While luminaires located under the reagent shelf can provide supplemental task illumination, the location of the light in relationship to the task can cause “veiling reflections” in certain materials. (See Glossary). Grazing light can be useful to detect texture and irregularities that might not be visible under totally uniform lighting. Greater flexibility is available for the lab worker by providing “articulated” task lights (a luminaire on an adjustable arm with joints that allow movement in two or three planes). These can be combined with a magnifying lens for small, hard to see tasks (see Sample Luminaire Schedule.) In BSL-3 labs, sealed and gasketed stainless steel luminaires can be used under the shelves, or even fitted to an adjustable stainless steel arm. Task lights must be wired to a wall switch in a BSL-3 lab, as integral rocker switches or pull cords can compromise the seal.

## Safety cabinet or fume hood task lighting

Many procedures that require the highest light levels are typically performed within a safety cabinet with integral fluorescent task lighting. Many laboratories also utilize chemical fume hoods and laminar flow hoods. In each case the lamps are separated from the contents of the chamber by safety glass panels or sealed luminaires. Lighting integral to such equipment is typically exempted from the energy codes. Even so, the client should be encouraged to order new cabinets with the high-performance lamps and ballasts recommended by DDC for reasons of energy conservation, maintenance and consistent color. Existing cabinets can usually be modified to accept the latest technology.

### Biological Safety Cabinets (BSC) Classifications

**BSC Class 1** – Partially open front offers primary protection for workers and environment.

**BSC Class 2** – Partially open front also offers protections from contamination to the materials being handled.

**BSC Class 3** – Sealed front with gloved panels for manipulation of the pathogens.

## Security lighting

Due to concerns about potential bio-terrorism, full-time security surveillance is expected in public health labs. If surveillance is from security personnel, a key-lock switch located outside the lab can be used to briefly turn on a selected portion of the ambient lights for viewing through the window(s) without entering the space. If cameras are used, they should be selected for the lowest possible light level (less than 1/10 of a footcandle). A few lamps or luminaires should be dedicated to the security lighting circuit, and activated only after the ambient light is turned off. There are many ways security lighting can be accomplished, but care should be given to avoid needless energy usage.

## Emergency lighting

A public health lab will typically be equipped with large emergency generators to be able to function even during a blackout. Even so, a redundant system of battery backup designed for emergency egress in case of loss of power is typically required. For security reasons, this is best done through the use of individual emergency battery/ballasts rather than larger inverters that can be disabled. A separate hot wire must be fed to the emergency fixtures on lighting controls, so that the battery will always be charged, even when the fixtures are turned off.

## Hazardous Location Classifications

See the Design Brief for Workshops for the chart of hazardous location classifications.

## ENERGY CODES: WATTS / SQUARE FOOT ALLOWANCES

FUNCTION	ENERGY CONSERVATION CONSTRUCTION CODE OF NEW YORK STATE		ANSI/ASHRAE/IESNA STD.90.1		NOTES
	-2002	+/- 2007	-1999/2001	-2004	
Laboratory – Whole Building					1
Laboratory space - general	1.6	1.2	1.8	1.4	2,3
Offices, reading tasks	1.5	1.1	1.5	1.1	4
Gown Room	1.6	1.2	1.6	1.4	2
Lobby	1.0	1.3	1.8	1.3	
Restrooms	0.8	0.9	1.0	0.9	
Corridor/Transition	0.8	0.9	0.7	0.5	
Stairs-active	0.8	0.9	0.9	0.6	
Active Storage	1.0	1.0	1.1	0.8	
Electrical/Mechanical			1.3	1.5	

1. Laboratories are not listed in the Whole Building category for either the NYS code or Standard 90.1. 2. Values listed are for laboratory spaces listed under the Office category of Standard 90.1-2001 version. 3. NYS code does not list any values for laboratories – the values provided are from the Medical and Clinical Care category. 4. Values listed are from the Open Plan Office reading tasks category.

## LIGHTING CONTROLS

### Laboratory – Ambient Lighting

Bi-level switching, which allows two levels of ambient light, is encouraged by the NYS energy code, but is not required if an occupancy sensor is used instead. Even in cases where occupancy sensors are used, consider providing bi-level switching in zones appropriate for the expected use of the space since many occupants will prefer to use task lights with lower ambient light levels—but this should be discussed with the client. In large laboratory rooms, consider separately controlling each bay or pair of adjacent aisles. Keep in mind that the lights in one aisle may be contributing to the ambient light (especially reflected off the ceiling) of workers in adjacent aisles.

Multiple-level control can be done in several ways: alternate lamp switching, continuous dimming, or stepped dimming. The ballast specification will differ in each case. If color rendering is critical to the lab task, then reduce light levels by turning off lamps in a uniform pattern rather than reducing the lamp output -- dimming alters the lamp color. For uniform two-level switching, specify that the ballasts in two-lamp fixtures be wired “in-line” so that each row of lamps can be controlled separately. With three-lamp luminaires, one can achieve three levels of light: the inboard lamp can provide 1/3rd of the light; the two outboard lamps can provide 2/3rd, and together they provide the highest illuminance level. If the electric lighting is responding to daylight, continuous dimming is the least distracting and recommended way to keep the light levels uniform. A high-level and low-level option could still be made available to the occupants by wiring the dimming ballasts “in-line”, that is, each linear row could be separately switched and dimmed. The use of special two- or three-level ballasts for “stepped dimming” essentially reduces the output all the lamps together in a luminaire. It is less desirable than multiple-row switching because the lamp color still shifts (the warmer-colored phosphors do not respond and the result is grayish) and the ballast operates less efficiently in the reduced configuration.

The energy codes require automatic turnoff in spaces when they are not occupied. Occupancy sensors are an effective way to meet this requirement. Consider ultra-sonic occupancy sensors with manual-on operation, so that high levels of energy are not consumed while the space is unoccupied. Infra-red sensors should be avoided because they may react to lab processes. When shelving separates the benches, a motion sensor must be located in each bay, even if multiple bays are controlled together. If the furniture layout is expected to be flexible, consider digital programmable or wireless controls.

### Laboratory – Task Lighting

Task lighting should be separately controlled by the lab worker at each bench, but all task lights should be wired to a control circuit so they can be automatically turned off by occupancy sensors or a time-clock. Dimmable task lights may be desirable for some functions, but the change in lamp color should be considered.

### Gown and De-Gown rooms

Changing rooms are most often found at the entrance and exit to BSL-3 laboratories, but they may occur in BSL-2 labs as well. Higher light levels are required for inspection, but only for a short duration. Here infra-red occupancy sensors with automatic On and Off operation are the best choice because they are hands-free. These rooms have view windows and will be receive “borrowed light” from the labs when unoccupied. The occupancy sensors should be calibrated to the highest sensitivity, with a short time-delay (say 5 minutes) after no motion is detected before turning out the lights. An alternative control scheme, for larger gown rooms, would be to have a low level of ambient light for normal hours of operation, and a higher level of light activated by an occupancy sensor or switch.

## OPERATIONS AND MAINTENANCE STRATEGIES

### Special Maintenance and Operational Issues

Specify the lighting system with control, operation and maintenance in mind. In addition to the capability of luminaires to withstand frequent cleaning and decontamination solutions, the system should be designed with sturdy equipment that is long-lived and relatively easy to maintain and clean, without sharp edges that can catch cleaning cloths. Other than cleaning, the need for access to the luminaires for repair or re-lamping should be minimized. The high-performance T8 lamps recommended by DDC maintain their full light output with less degradation over time than conventional T8s. Lamps should be specified in “extended-life” versions, achieving a rated life of up to 30,000 hours. As with all buildings, the number of lamp types should be minimized. In BSL-3 labs, luminaires designed for IP-65 or Clean Room criteria will be tightly sealed and gasketed with multiple points of hardware penetration. Select fixtures that require the fewest tools to access, and have features like hinges, safety chains and captive screws.

### Dirt Depreciation

When performing light level calculations, luminaire dirt depreciation (LDD) will be minimal because of the use of sealed and gasketing luminaires, and frequent cleaning of exposed lamps or surfaces. Room surfaces will also be cleaner. (See Lighting Technologies regarding cleaning assumptions.)

### Commissioning

Commissioning of laboratory lighting is critical, especially for daylighting systems and all lighting controls. Commissioning criteria should be well-defined in the specifications, and it must be completed and approved prior to move-in so laboratories can be decontaminated prior to use. Consider “self-learning” occupancy sensors that require less fine-tuning after occupancy. See the DDC website for commissioning specification language.

## ACKNOWLEDGEMENTS

Review and comments provided by Ken Mohr, Barbara Spitz and Laurie Sperling of Health, Education + Research Associates Inc., St. Louis, MO and Philadelphia, PA; Glenn Heinmiller, Lam Partners Inc., Boston, MA, MaryAnn Hay of Syska Hennessy Group, NY, NY, and Samantha LaFleur of The RETEC Group, New Haven, CT.

## REFERENCES

<sup>1</sup>Best Practices, Electric Lighting in Laboratories, to be published in late 2006. Ken Kozminski, Stuart Lewis, Paul Mathew. Available from [www.labs21century.gov/toolkit/best\\_practices](http://www.labs21century.gov/toolkit/best_practices).

<sup>2</sup>Laboratory Biosafety Level Criteria, Center for Disease Control, U.S. Department of Health and Human Services <http://www.cdc.gov/od/ohs/biosfty/bmbl4/bmbl4s3.htm>

<sup>3</sup>Daylighting in Laboratories – Best Practices, Laboratories for the 21st Century, Nancy Carlisle, [www.labs21century.gov/pdf/bp\\_daylight\\_508.pdf](http://www.labs21century.gov/pdf/bp_daylight_508.pdf)

<sup>4</sup>Case Studies, Laboratories For the 21st Century, a program of the U.S. Environmental Protection Agency and U.S. Department of Energy. Phil Wirdzek, Will Lintner, Nancy Carlisle. [http://www.labs21century.gov/toolkit/case\\_studies.htm](http://www.labs21century.gov/toolkit/case_studies.htm)

<sup>5</sup>Airborne Particulate Cleanliness Classes, <http://www.clean-rooms.com/regul.asp>

Biosafety in Biomedical and Microbiological Laboratories, National Institute of Health <http://bmbl.od.nih.gov/sect3bsl1.htm>

The Basics of Lighting for Biosafety Environments, Kurtzon Lighting Inc. [www.kurtzon.com/Catalog/pdf/BioSafety.pdf](http://www.kurtzon.com/Catalog/pdf/BioSafety.pdf)

For reduced energy consumption, the following four-foot long fluorescent lamps are the DDC standard: 32 Watt T8, 3,100 lumen, CRI 85+, 3500 Kelvin, low mercury, extended life (24,000 – 30,000 hours). Note that DCAS (NYC Department of Citywide Services) will have available one of the following lamps: GE #F32T8 XL SPX35 HLEC (10326); Philips #F32T8/ADV/835/ALTO (13988-1); Osram/Sylvania #FO32/835/XPS/ECO (21697).



## SAMPLE LUMINAIRE SCHEDULE FOR LABORATORIES

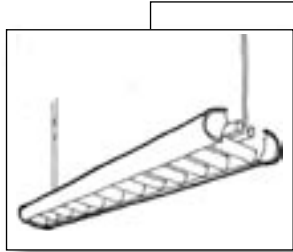

### PENDANT FLUORESCENT DIRECT / INDIRECT

**Location:** BSL-2 Labs  
**Lamps in profile:** (1-3) 32W, High Performance T8, 835 color, extended life.  
**Description:** Pendant-mounted fluorescent luminaire in lengths of 4'-0" to 12'-0" using 4' lamps only. White polyester powder coat baked enamel housing and cross blade louvers. In-line wiring for control of each row of lamps independently, or continuous dimming ballasts. Minimum 92% efficiency. Electronic high-efficiency multi-lamp ballasts. Emergency battery/ballasts where indicated.

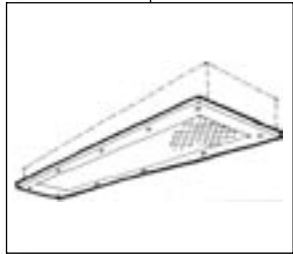

### FLUORESCENT CLEAN-ROOM RECESSED TROFFER

**Location:** BSL-3 and BSL-4 Labs  
**Lamps in profile:** (1-3) 32W, High Performance T8, 835 color, extended life.  
**Description:** Recess-mounted 1'x 4' (or 2'x 4') fluorescent luminaire with one-piece sealed housing. Clean Room Class 100, crevice free, triple-gasketing. Low-brightness batwing acrylic or glass lens. Lens protrusions on inside of housing. Stainless steel housing and door, with brushed satin finish. Options: AgION anti-bacterial finish, UV shielding, RFI shielding. Minimum fixture efficiency X%. Electronic high-efficiency ballasts. Wired for bi-level switching or continuous dimming. Emergency battery / ballasts where indicated.



### FLUORESCENT CLEAN ROOM SURFACE TROFFER

**Location:** BSL-3 and BSL-4 Labs  
**Lamps in profile:** (2) 32W, High Performance T8, 835 color, extended life.  
**Description:** Similar to recessed Clean Room Troffer. Surface-mounted 1'x 4' (or 2'x 4') fluorescent luminaire with one-piece sealed housing. Clean Room Class 100, crevice free, gasketing between lens and doorframe, and between doorframe and housing. Sealed electrical compartment to accept vapor-tight electrical connection.

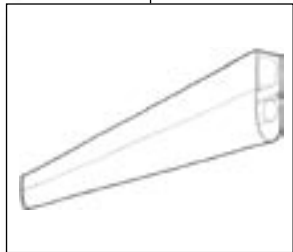

### FLUORESCENT CLEAN ROOM TEARDROP

**Location:** BSL-3 and BSL-4 labs, fume hoods, laminar flow clean rooms, task lights.  
**Lamps in profile:** (1) 32W, High Performance T8, 835 color, extended life.  
**Description:** 4'-0" long ceiling-mounted or T mounted fluorescent sealed luminaire with continuous elongated wrap-around diffuser to promote vertical laminar airflow. Sealed diffuser fits into U-channels at end caps. Intermediate sealed joiners for continuous rows. Clean Room Class 10. Stainless steel housing with optional polyester painted finish or AgION anti-bacterial finish. Electronic high-efficiency ballasts. Emergency battery/ballasts where indicated.

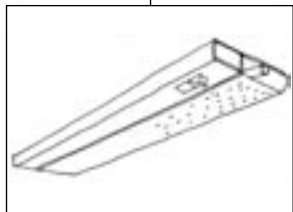

### UNDERSHELF FLUORESCENT TASKLIGHT

**Location:** Under shelves and cabinets, BSL-2 and BSL-3 labs  
**Lamps:** (1) 28-32W, High Performance T8, 835 color, extended life.  
**Description:** Linear fluorescent tasklight mounted under shelf or cabinets. Clear ribbed acrylic diffuser (BSL-2) or prismatic diffuser with flat side down (BSL-3). Mount at front edge of cabinet, with solid front to hide lens brightness. Orient so that acrylic diffuser aims at back wall. Local rocker switch (BSL-2) or hard-wired to wall switch (BSL-3). Consider 50% output ballast, two-level ballasts, or dimming ballasts.

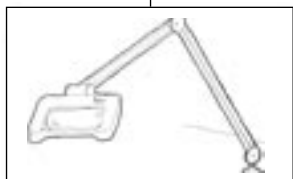

### FLUORESCENT ARTICULATED LIGHT WITH MAGNIFIER

**Location:** BSL-2 and perhaps BSL-3 labs  
**Lamps:** (1-2) 13W quad CFL or (1) T5 circular lamp for circular housing; 835 color  
**Description:** Rectangular or circular housing with fully articulated arms that allow adjustment in three planes. Opaque shade and optional central magnifying glass. Grommet-mounted plate sealed to workbench. Integral 120v electronic ballast.



IMPLEMENTATION  
RESOURCES

## LIGHTING TECHNOLOGIES

Quality lighting, energy conservation, and appropriate design strategies for DDC project types are the overall aims of this handbook. Putting all that together requires both expertise and technology. This section explains the basic equipment used in a comprehensive lighting concept and the key variables that designers should consider when selecting lighting system components. There are no absolutes, and choosing the right combination of lamp-ballast-controls is based as much on experience as metrics.

Now is an exciting time in the lighting design field, with equipment options evolving rapidly in response to energy conservation concerns, user expectations and technological advances. Designers can count on more control and more reliability in the future. The compatibility of various components also is improving. Still, the design of a quality, energy effective, lighting strategy will depend on tailoring the technology to the user needs, especially for the diverse projects of the DDC.

Technologies discussed here are:

- **Lamps**
- **Ballasts**
- **Controls**

In each of these technologies, there have been major advances that have led to vastly increased efficiencies. In lamps, there was the invention of fluorescent sources, followed by improved lamp shapes - T8, T5 and compact fluorescent. The electronic ballast is significantly more efficient than the older magnetic ballasts were for fluorescent lights. And, finally, new sensors and dimmers allow lights to be used only when needed. The combination of all these technological improvements means much lower energy consumption, and this is reflected in the new energy code requirements.

### LAMPS

The lamp is the source of electric light, the device that converts electric power into visible light. Selecting the lamp types is at the heart of a high quality lighting plan, and central to visual performance, energy conservation and the appearance of a space. Various light sources have different characteristics, but the basic performance principles include the following:

- **Lumen output** – the amount of light emitted by a lamp
- **Efficacy** – the efficiency of lamps in producing light
- **Rated lamp life**
- **Lamp lumen depreciation** – the loss of lumen output over time (CCT and CRI)
- **Color** – the appearance of the light and the objects illuminated
- **Reduced mercury lamps**

**EFFICACY** is the amount of light (lumens) produced relative to the electric power expended, and is measured in lumens/watt (see Glossary). A lighting system using high efficacy sources will provide the light needed while conserving more energy. Because of their methods for converting electricity to light, various lamps create light at different efficiencies, with incandescent or halogen lamps at less than 25% of the efficacy of linear fluorescents. Efficacy is most accurately determined for lamp-ballast combinations, (called lamp-ballast system efficacy), reflecting the ballast's major contribution to performance. See the comparison chart in the Overview.

**RATED LAMP LIFE** is provided by the manufacturer and represents the point in time when 50% of a group of lamps have burned out under controlled testing with lamps switched on 12 hour intervals. Rated lamp life is useful in comparing different sources, in developing a maintenance plan for group relamping, and for life cycle cost analyses. There is not usually significant variation in rated life between manufacturers of similar lamps. Manufacturers publish "lamp mortality curves" that diagram the pattern of burnouts

over the rated lamp life. These are useful in determining exactly when group re-lamping is most economical, (typically at about 70%-80% of rated lamp life for fluorescent). Actual lamp life can vary significantly, based on the time between switch-ons. Frequent switching will greatly reduce lamp life, unless the cathodes are protected by a “programmed-start” ballast. (See ballasts). Manufacturers publish guidelines for estimating the reduced lamp life of lamps switched more frequently than twelve hours. This is typically provided at a frequency of three-hours per start.

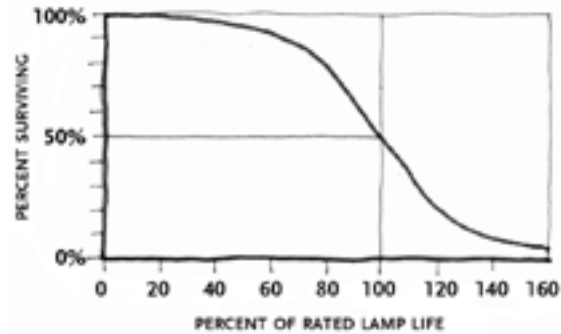

Fluorescent Lamp Mortality Curve

**LAMP LUMEN DEPRECIATION (LLD)** represents the decrease in light output of a lamp over time. Lamp catalogues provide both “initial lumens” and “mean lumens”, the former measured after 100 hours, and the latter occurring at 40% of the rated lamp life. Mean lumens can be used in calculations to determine maintained illuminance (also called design footcandles). Alternatively, designers can request lumen maintenance curves from manufacturers that show the pattern of lumen loss over the entire rated lamp life. This curve can be used to determine an actual LLD value to add to the “Light Loss Factor” in calculations. In this calculation, the initial lumens are used rather than the mean lumens.

**COLOR** characteristics of lamps are important factors in evaluating the best sources for a specific application. The lighting designer today can satisfy color requirements with a broader choice of lamps thanks to advancing technology in lamp design. Lamp color is defined by two factors: color temperature; and color rendering. Both factors can be used to compare lamps because they are defined according to international standards and are published by the manufacturers.

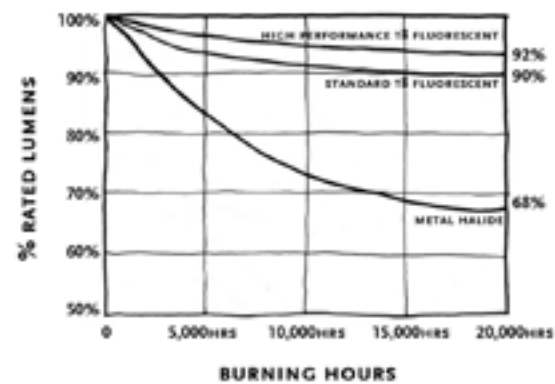

Lumen Maintenance Curves

Color temperature is an indicator of the “warm” or “cool” appearance of the lamp and the light it casts. The term used is Correlated Color Temperature (CCT), and is expressed in degrees Kelvin (K). Lamps with a lower color temperature, 3000K or lower, will appear warm. For example, incandescent and halogen lamps typically have color temperatures of 2700K and 3000K respectively. Lamps with medium color temperatures (3500K-4000K) are more balanced in color wavelengths and appear neutral or white. This range is the most common in offices and similar applications. Color temperatures higher than 4000K make the light appear cool or slightly blue. While the old standard “cool white” fluorescent lamps have a CCT of 4100K, current 4100K lamp colors have superior color rendering characteristics. Cool colors are most often used to supplement daylight in spaces not typically occupied after dark. As a reference, daylight (skylight) has a very cool CCT of approximately 5000K to 10,000K while direct sunlight has a CCT of 4000-5500 Kelvin.

Color rendering indicates how “realistic” the colors will appear, compared to how we expect them to look. The measure is the Color Rendering Index (CRI), which ranges from 0 to 100. Objects and people viewed under lamps with a high CRI look more natural. The color rendering index of a lamp is compared to a reference source of the same color temperature. At the two extremes, incandescent lamps have a CRI of 100, and low-pressure sodium, under which everything looks yellow, grey or black, has a CRI of 0. Linear fluorescent lamps are usually specified with a CRI of 70+ (i.e., between 70-79), 80+ or 90+. Higher values yield a much better appearance, but the lamps cost more and at the current time, lamps above 90 CRI are coupled with lower efficacies. Compact fluorescent lamps typically range from 82-85 CRI and metal halide 65-85 CRI. There is some research that indicates that spaces appear brighter and visual acuity is improved with bluer sources (from 5000K to 6500K) and with a CRI above 90. Consensus has not yet been reached

on the degree of improvement, and DDC is performing an experiment – to be the subject of a future report – to test the visual impact of bluer 4500K lamps with high CRI.

Dimming or reduced-output ballasts can affect the color of the source, typically shifting the CCT and reducing the CRI. Incandescent lamps become warmer in appearance, reducing their CCT and CRI. Fluorescent sources lose the warmer phosphors when output is reduced, so that they appear greyer to the eye and reducing their CRI. HID sources have exhibited similar effects with reduced output, and the phosphors often become unstable, so that adjacent lamps no longer match.

**“Full-spectrum” lamps** are sometimes suggested when selecting fluorescent lamps. There is no recognized definition for full-spectrum and no proof of claims for the purported health benefits. “Full-spectrum” is a marketing term used to describe an electric light source that emits all colors in the visible spectrum in relatively uniform amounts, without sharp peaks or discontinuities. The goal is to simulate natural daylight as it occurs at noon with a light cloud cover, resulting in a very “cool” appearance. Some have defined it more precisely as a lamp with a CRI above 90%, a CCT of 5000+, and peak ultra-violet (UV) emissions in the 315-400nm range. Research suggests that high CRI and high CCT may produce better visibility per watt. However, the degree of improvement compared to the high quality 85 CRI and 3500-4100K lamps currently recommended by DDC, has not yet been determined. More importantly, lamps with high CRI and high CCTs are available by the major manufacturers at a fraction of the cost of the full-spectrum lamps. The UV component of full-spectrum lamps was promoted for health benefits (i.e., vitamin D production), but manufacturers were forced by the government to remove such claims from their advertising.

Full-spectrum light sources manufactured today produce less visible light per watt, so substituting full spectrum lamps for recommended fluorescents would result in reduced lighting levels, lower energy efficiency, a five-fold increase in cost, and a color that would be considered unacceptably ‘cool’ by most of the occupants. Extensive use of full-spectrum lamps would likely exceed the energy code. They are not recommended unless it can be demonstrated that a specific full-spectrum lamp has true benefits over less costly and more efficient alternatives with a similarly high CCT and CRI. More information is available in a study of full-spectrum issues prepared by the Lighting Research Center. See <http://www.lrc.rpi.edu> under their NLPIP Lighting Answers series.

**Reduced-mercury fluorescent lamps** are available from the “big three” lamp manufacturers (GE, Philips and Sylvania) and are marketed under the trade names Ecolux, Alto and Ecologic, respectively.

They are recommended for all DDC projects to reduce the release of toxic wastes into the environment. Even if low mercury lamps are used, DDC requires that all used fluorescent lamps be recycled during demolition. Recycling is also recommended as a standard maintenance strategy. (See the DDC Construction and Waste Specification on the DDC website).

## ELECTRIC LIGHT SOURCE TYPES

Electric lamp types are characterized by the process used to create light from electricity. The most commonly used lamps in DDC projects include:

- Fluorescent sources, both linear and compact
- High Intensity Discharge (HID), primarily metal halide
- Electrodeless induction lamps, in limited applications
- Incandescent, including halogen, in limited applications.
- LED, or Light emitting Diodes, in limited applications

## FLUORESCENT LAMPS

Fluorescent lamps generate their light by using electricity to excite a conductive vapor of mercury and an inert gas. The resultant ultraviolet light strikes a phosphor coating on the inside of the tube, causing it to glow. The elements used in the phosphor coating control the lamp's color.

### Fluorescent Lamp Advantages

- Very high efficacy – T8/T5 lamps are 80 to 98 lumens per watt
- Flexible source with a wide range of colors, high (75 to 98) CRI, sizes and shapes
- Very Long lamp life: 20,000 to 30,000 hours
- Cool operation
- Low diffused surface brightness

### Fluorescent Lamp Disadvantages

- Require a compatible ballast
- Dimming requires a more expensive ballast
- Temperatures can affect start-up, lumen output and lamp life
- Not a point source if narrow beam distribution is required

### Appropriate Uses

- Fluorescent and compact fluorescent lamps are appropriate for most of the applications that DDC encounters in their buildings.

Sizes and shapes are available to suit the desired application and effect, and they have their own characteristics. The most common are:

#### T12 lamps

Linear fluorescent lamps with a 1-1/2" diameter (12/8's of an inch). [They are now considered obsolete for most new applications.] These were the standard fluorescent lamps until T8 lamps came on the market in the 1980s.

#### T8 lamps

Linear fluorescent lamps with a 1" diameter (8/8's of an inch). These are the workhorse of the commercial lighting industry and have become the standard for offices and general applications. Since they are 22 % more efficient than T12s, it is always cost effective to retrofit or replace fixtures that use T12 lamps in existing applications. NYC, through its Office of Energy Management at DCAS, has had a replacement program for many years to replace T12s with T8s in municipal buildings. T8 lamps use the same socket as T12, but not the same ballast. It has been relatively easy to retrofit T12 installations, often with the assistance of NYC's Department of Citywide Administrative Services (DCAS). There is a wide range of T8 design options and good color rendition. The most commonly used T8 lamp is 4-foot long and 32-watts (F32T8).

#### High Performance T8 Lamps

"High Performance" or "premium" T8 lamps are marketed under the tradenames Ultra (GE), Advantage (Philips), or Super T8 (Sylvania). These T8 lamps provide 7%-10% higher efficacy, higher maintained lumens and are available in extended life versions with a 20% increase in lamp life. The improved performance is achieved in different ways by different products. Some products have reduced wattages (28-30 watts) while achieving the same lumen output as a standard T8. Reduced wattage T8 lamps cannot be dimmed. Others have increased lumen output (3100 lumens) without increasing the wattage. The increased lumen

## HOW TO READ A GENERIC LAMP DESIGNATION:

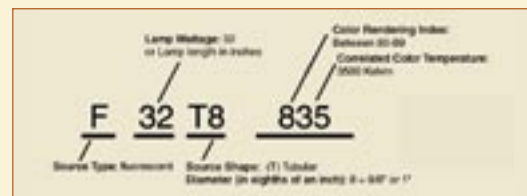

Unfortunately, most lamp manufacturers use their own marketing designations, but sometimes list the generic alongside, or in a cross-reference guide in the back of their catalogues.

output results in a brighter lamp and potentially more glare. This can be prevented by coupling a 3100 lumen lamp with a reduced output ballast (.77 BF) (see Ballasts, below), which provides similar output to a standard T8 lamp (2950 lumens) and a standard .89 BF ballast, but has a higher efficacy (lumens/watt). *High Performance premium T8s have a higher initial cost but the increased energy efficiency makes them the recommended light source for most DDC projects.* See Glossary for additional criteria.

### T5 lamps

Linear fluorescent lamps with a diameter of 5/8's of an inch. These cannot replace T-8 lamps because they have different characteristics and different lengths (metric), socket configurations and ballasts. T5s are smaller lamps than T8s, but have similar efficacy (lumens per watts). Their smaller diameter allows for shallower fixtures and greater reflector control, but also increases the brightness, limiting their use to heavily shielded or indirect fixtures.

### T5HO (high output)

T5 lamps with approximately the same maintained lumens as two standard T8 lamps but less efficient, with about 7-10% fewer lumens per watt. This development allows the designer to potentially reduce the number of fixtures, lamps and ballasts in an application, making it less expensive to maintain. However, the intense brightness of T5HOs limits their use to primarily indirect luminaires to avoid glare. Also, using one-lamp rather than two-lamp luminaires eliminates the potential for two-level switching. Analysis is required to demonstrate the benefits of using T5HO lamps to offset their lower efficacy and higher cost.

### Compact Fluorescent lamps (CFLs)

Fluorescent lamps with a single base and bent-tube construction. Originally designed for the retrofitting of standard incandescents, the first CFLs had a screw-type base. While screw base lamps are still available, commercial applications typically use lamps with a 4-pin base. This prevents the future replacement of a screw-based CFL with a much less efficient incandescent lamp. CFL lamps have a wide range of sizes and attractive colors, and can be used in most DDC applications that formerly used incandescent.

### Compact Fluorescent Lamp Advantages

- Good substitution for most incandescent lamps
- High efficacy – 56 to 71 lumens per watt.
- Flexible source with a wide range of sizes and shapes, and good color rendering (82 CRI)
- Long lamp life: 10,000 to 12,000 hours
- Cool operation
- Diffused surface brightness

### Compact Fluorescent Lamp Disadvantages

- Require a compatible ballast
- Dimming requires a more expensive ballast
- Temperatures can affect start-up, lumen output and lamp life
- Not a point source if narrow beam distribution is required

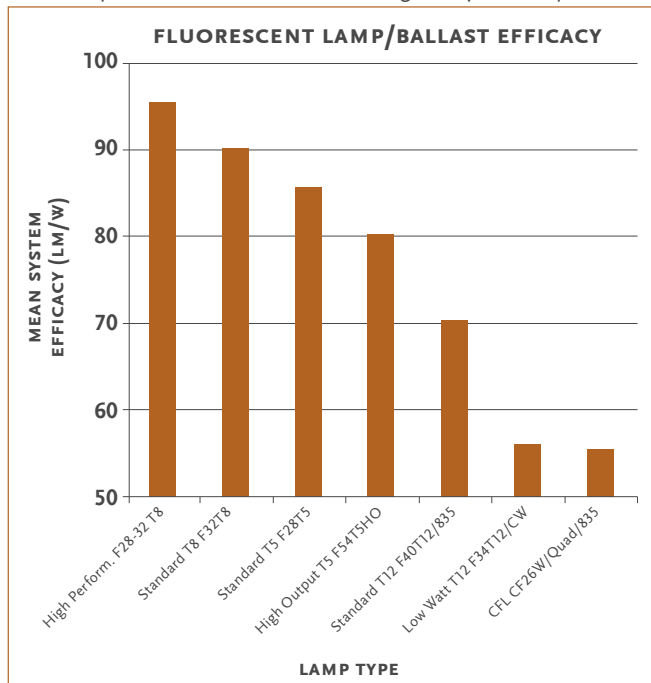

Fluorescent lamp-ballast efficacy comparison

## HIGH INTENSITY DISCHARGE (HID) LAMPS

High Intensity Discharge (HID) lamps also use a gas-filled tube to generate light, but use an arc current and vaporized metals at relatively high temperatures and pressures. There are two main types in current use – metal halide (MH) and high-pressure sodium (HPS) – and their characteristics are determined by the gas. Metal Halide provides a white light with a CRI of 65-95, while HPS emits a yellowish light with a CRI of 22-65. Historically, HID lamps were relegated to outdoor or service areas, but advances in color, configurations and efficacy have made them more attractive for commercial and interior use.

### HID Lamp Advantages

- High lumen output – up to 1000 wattage lamps available
- Medium to high efficacy – MH: 51-85 lumens per watt; HPS: 60-115 lumens per watt.
- Long lamp life – MH: 10,000 to 20,000 hours; HPS: 10,000 to 24,000+ hours.
- Insensitivity to ambient temperatures
- 50% and 100% bi-level switching ballasts available

### HID Lamp Disadvantages

- Lamps have a warm-up period before reaching full output/color
- If power is interrupted, lamps must cool off before restriking (hence unreliable dimming and unacceptability for emergency lighting). Some HPS lamps are available with instant restrike.
- Inappropriate for many control strategies like daylight harvesting, occupancy sensors or frequent switching.
- Yellow output and low CRI of high pressure sodium are less effective than bluer and higher CRI sources for night-time visual acuity.

### Appropriate Uses

- Metal halide lamps come in a wide range of shapes and colors, and are suitable for most lighting applications where continuous operation is required. “Ceramic” metal halide technology provides colors in the 80-95 CRI range with a warm color temperature of 3000K
- Metal halide PAR and small tubular lamps provide an energy efficient substitute for many types incandescent/halogen reflector and tubular lamps
- High-pressure sodium (HPS) lamps are most often used in roadway, NYC streets and other outdoor applications. Lamp life is very long (30,000+ hours), but the CRI is low (about 22-30). Improved whiter HPS lamps are available with a CRI of 65, but as color improves, efficacy and life are reduced.

## ELECTRODELESS LAMPS

Electrodeless lamps (also called induction lamps) most commonly utilize radio frequency to ionize mercury vapor at low-pressures, resulting in exciting the phosphors inside the envelope to create a glow, similar to fluorescent technology. The three major lamp manufacturers each produce a distinctive lamp design, the small reflector “Genura” lamp by GE, the globe-shaped “QL” by Philips, and the high-output donut-shaped “Icetron” by Sylvania. Electrodeless lamps are installed in the post-lanterns at Union Square Park in Manhattan.

### Electrodeless Lamp Advantages

- Very long life (100,000 hours) due to lack of electrodes to deteriorate
- Good maintained lumen output over life
- Low to high light output available (1,100 – 12,000 lumens per lamp)
- Medium to high efficacy (40-60 lumens/watt)

### Electrodeless Lamp Disadvantages

- Not interchangeable with other lamps and ballasts. No competition.
- Only one manufacturer per lamp style (donut, reflector, globe)
- Limited to diffuse distribution
- Limited wattages and lumen output for each style
- Requires magnetic core, which has shorter life than the lamp



Genura Reflector lamp



QL globe shape



### Appropriate Uses

- Locations where maintenance is expensive or difficult
- Replacement reflector lamp for incandescent floodlight in high ceilings
- Locations where high lumen output and diffuse distribution is desirable (indirect kiosks in high ceilings)
- More information is available from the manufacturers and the Advanced Lighting Guidelines.

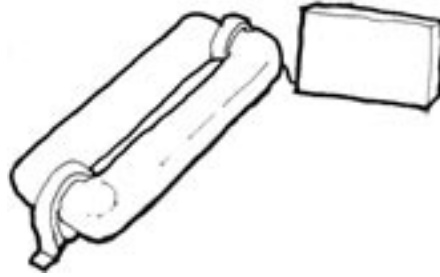

Icetron donut shape

## INCANDESCENT/HALOGEN LAMPS

Incandescent/Halogen lamps generate their light by heating a tungsten filament until it glows in the presence of an inert gas such as argon or nitrogen. A halogen lamp is a form of incandescent lamp that introduces traces of halogen gas and a quartz envelope to burn hotter and prolong the filament life. Consequently, they are whiter (3000K rather than 2700K) and are slightly more energy efficient than standard incandescents. Halogen should be used in lieu of standard incandescent, and low voltage should be considered for the tighter, more focused beam. However, whenever possible, the use of more efficient CFL or ceramic metal halide sources should be explored. Since incandescent/halogen lamp types are very inefficient (roughly five times less efficient than fluorescent,) they should be used sparingly, or the project will not meet the energy code. See the suggested uses below.

### Incandescent/Halogen Lamp Advantages

- Excellent color rendering and a warm appearance
- Can be focused for use in reflector lamps
- Compact size
- No ballast required
- Easily dimmed
- Minimal ultra-violet emissions for conservation of light sensitive materials

### Incandescent/Halogen Lamp Disadvantages

- Low efficacy – Halogen is the best of the independent sources, but still only provides 13 to 21 lumens per watt.
- Shorter lamp life than alternatives – Halogen is the best at 3,000 to 6,000 hours
- Lamp can get very hot and can even cause fires if it shatters or comes in contact with flammable material.
- Low voltage transformers may be required for halogen lights
- Point source is glary if not shielded.

### Appropriate Uses

- Historic settings when CFL lamps cannot be used
- Applications in which color rendering is extremely important (art work, limited retail)
- Displays where the narrowest beam control is necessary

## LIGHT EMITTING DIODES (LEDS)

Light Emitting Diodes (LEDs) are made of an advanced semi-conductor material that emits visible light when current passes through it. Different conductor materials are used, each emitting a distinctive wavelength of light. LEDs come in red, amber, blue or green and a cool white, and have limited applications at this time.

### LED Lamp Advantages

- Impact resistant
- Operate best at cooler temperatures so good for outdoor applications
- Small size

- Low to medium efficacy, depending on the color. Red is highest, followed by amber, green, white and blue. A more efficient white light can be created by combining red, green and blue LEDs. White LEDs are currently about 30 lumens per watt, but efficacies are expected to increase steadily.
- Monochromatic color (red, amber, green, blue) for exit signs, signals and special effects
- Effective for rapid or frequent switching applications.

#### LED Lamp Disadvantages

- Rapid lumen depreciation: White LEDs may last 12,000 hours or longer, but “useful life” is only 6,000 hours, the point at which point light output has reduced 50% .
- Monochromatic color
- Heat buildup
- Cost
- White LEDs are still bluish and provide low lumens per watt, similar to incandescent. Both conditions are expected to improve rapidly over the next 15 years.

#### Appropriate Uses

- Currently used primarily in exit signage, traffic signaling, and certain special effects
- Excellent for projecting words or an image – as in walk/don’t walk signs or exit signs. DDC recommends them for these uses.
- LED sources may have the greatest potential for technical improvements and new applications over the next 15 years.

## BALLASTS

Ballasts are electrical devices that provide the necessary high starting voltage, and then limit and regulate the current to the lamp during operations. All gas discharge lamps, like fluorescent and high intensity discharge (HID), require ballasts, (incandescent lamps do not). Ballasts typically are designed to efficiently operate a specific lamp type, so lamps and ballasts are chosen together. The final ballast product selection is usually done by the fixture manufacturer, in response to the lighting designer’s minimum performance requirements (see Specifications on the website). In specifying ballasts, the basic performance criteria to consider include the following:

- Ballast Factor (BF)
- Lamp-Ballast System Efficacy
- Ballast Efficacy Factor (BEF)
- Power Factor (PF)
- Total Harmonic Distortion (THD)
- Minimum Starting Temperature
- Voltage requirements
- Distance between lamp and ballast

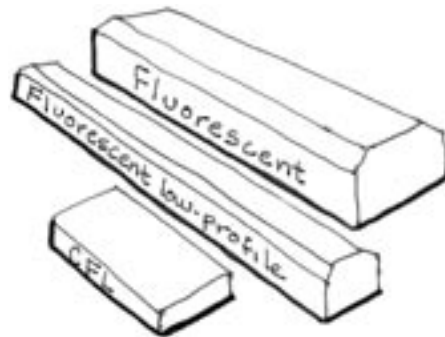

Three fluorescent ballast shapes

**Ballast Factor** (BF) indicates the percentage of the rated lumen output that will actually be produced by a lamp operated by a specific ballast, since there are often losses when operated together. It is a reference measure, comparing the actual lumen output for a lamp/ballast type to an ANSI standard reference. Fluorescent ballast factors range from 0.77 to 1.20 - the standard ballast factor is 0.88 for T8 and 1.0 for T5. A ballast factor can be greater than 1.0, which means that the lamp will operate at more than its rated lumens, but this “overdriving” tends to shorten lamp life. Lower BF values (0.50 -0.78) are available when full output is not required. The ballast factor is not a measure of energy efficiency – a lamp/ballast combination with a low BF will reduce light output, but also draws less power. However, the power reduction is often not proportional to the output reduction, so the efficiency of low BF ballasts should be determined. The range of ballast factors allows lighting designers’ flexibility in layout/design. Fewer lamps with high BF ballasts might be appropriate to meet the light level requirements in some situations, while more lamps with lower BF ballasts would be appropriate in others.

**Lamp-Ballast System Efficacy** is the measure of energy efficiency for the combined lamp and ballast, expressed in lumens per watt and a high lamp-ballast system efficacy is desirable. It is the product of the initial rated lumens per lamp, the number of lamps per ballast, and the ballast factor of the system, all divided by the total system input wattage (ballast catalogues contain the last three factors). Lamp-Ballast System Efficacy is used to compare similar lamp-ballast combinations, or to make comparisons between different light sources. For example, to compare a two-lamp T8 system with a one lamp T5HO system.

**Power Factor** is the efficiency of the ballast to transform the supplied voltage and current into power. A high power factor is defined as 90% or higher, and a normal power factor is below 90%. Only high power factor ballasts should be used. All electronic ballasts are high power factor.

**Total Harmonic Distortion (THD)** is the distortion produced by an electronic ballast on the alternating current (AC) waveform. Excessive levels of THD can interfere with other appliances and the operation of electric power networks. THD values less than or equal to 20% are suitable for most applications.

**Minimum Starting Temperature** is the minimum ambient temperature at which a ballast/lamp combination can start. This typically ranges from -20°F to 50°F. In order for lamps to operate outdoors in the winter, cold start ballasts are required.

**Locating a ballast or transformer remotely from the lamp** is necessary in some applications (overly hot/cold environments, physical size restraints, etc.) Fluorescent dimming ballasts must be mounted quite close to the lamps (5-8 feet from the farthest socket) but non-dimming ballasts can be located farther away. Wire gauge will have to be sized appropriately for the distance and equipment, to prevent voltage loss. Protective ballast containers should be specified to match the weather conditions of the remote location. Design guidance and specification should be obtained from both lamp and ballast manufacturers for every specific combination of remote ballast, lamp and environment.

**Hazardous Material**, specifically PCBs, is found in older magnetic ballasts, but not in electronic ballasts. In demolition and retrofit projects, the magnetic ballasts must be disposed of as hazardous waste.

## BALLAST TYPES

There are two main types of ballasts used in commercial applications, magnetic (core and coil) and electronic (solid-state). Magnetic ballasts are the older technology, with a core of steel plates wrapped in copper windings. Fluorescent magnetic ballasts are significantly less energy efficient than electronic ballasts, and are being gradually phased out due to Department of Energy restrictions. Almost all commercial fluorescent luminaires are provided with electronic ballasts as a standard. Electronic ballasts utilize solid-state technology to operate at much higher frequency (20,000 Hz) than magnetic ballasts (60 Hz), resulting in energy conservation through lower power loss and higher lamp efficacy for fluorescent lights. Higher first costs, if any, are quickly offset by energy savings. Electronic ballasts are required in DDC fluorescent lighting applications, both new and retrofit.

### Electronic ballast advantages:

- Energy efficiency
- Multiple lamp operation, from one to four lamps
- Can replace magnetic ballasts in a retrofit
- Lamp flicker is eliminated
- Quieter than magnetic ballasts
- Non-toxic materials
- Lighter weight

HID lamps have used magnetic ballasts until recently. For HIDs greater energy efficiency is not the reason for the shift to electronic ballasts, because HID lamps are not significantly more efficient at higher frequencies. Here, electronic and hybrid ballasts have been introduced for better lamp performance, i.e., precise control of the arc current.

## BALLAST STARTING METHODS

Ballasts can utilize several starting methods for fluorescent lamps: instant start; rapid-start; programmed-start; and preheat. Preheat ballasts are all magnetic and not described here.

**Instant-Start Ballasts (IS)** start the lamps quickly by supplying relatively high voltage, but without heating the electrodes. Less power is used to start the lamps, so they use fewer watts, but lamp life may be reduced. They are most appropriate when long burning cycles are planned. Instant start ballasts operate in parallel, meaning that if one lamp burns out, the other continues to operate. *Generally, we suggest the use of instant-start ballasts on DDC projects, even when used with occupancy sensors – the energy savings is more significant than the possible lamp burn-outs caused by frequent switching.* An exception would be a location in which lamp replacement is very difficult. When the new generation of programmed-start ballast matches the energy efficiency of instant-start ballasts, then they will be the best choice for conditions of frequent switching.

**Rapid-Start Ballasts (RS)** start the lamps with a brief delay while they heat the lamp electrodes to reduce the amount of voltage required to start the lamps. This used to be the most common type of fluorescent ballast used in office settings, and is still the mode of operation for dimming ballasts. Rapid start ballasts are less energy efficient than instant-start ballasts.

**Programmed-start (PRS)** ballasts are rapid-start ballasts that use new technology to better control the starting process and extend lamp life. This extension can be up to two times that of standard RS or instant start ballasts under conditions of frequent switching, (more than five on-off cycles per day), such as where luminaires are switched by occupancy sensors or photocells. Current PRS ballasts are less energy efficient than instant start, although a new generation of programmed start ballasts with lower input wattages is expected from all the major ballast manufacturers in 2004-5, and these should be considered. Programmed start ballasts most often operate in series, meaning that if one lamp burns out, the second will not operate. Consider parallel operation when it is available.

**Dimming Ballasts** typically use the electronic rapid-start methodology, and dim the fluorescent lamps by reducing the current. They maintain the lamp voltage while reducing the power, which allows dimming and maintains the lamp life. Dimming ballasts come in different ratings - the most expensive can dim to

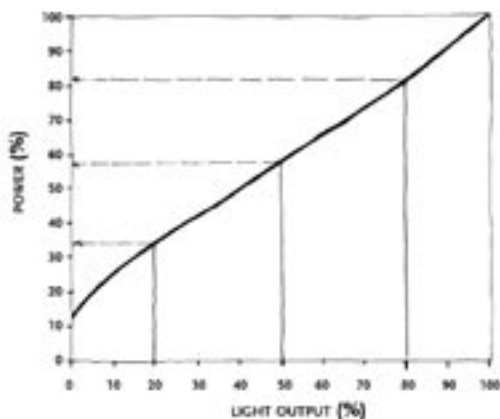

Fluorescent and CFL dimming ballast curve

approximately 1% of full output and are most often used for audio visual spaces. Others have minimum settings of 5-20% of full light output. These are less expensive, and appropriate for daylight harvesting, light level flexibility or other less demanding application. Dimming ballasts save operating costs, although they are more expensive initially. Smooth and continuous dimming is the preferred strategy for automated daylighting controls in offices or other work areas, since it is not distracting to the workers. Dimming ballasts may be less efficient than non-dimming ballasts, at reduced light output. At only 5% of full light output, a dimming ballast might still be using 20% of the input wattage. The new DALI ballasts (see Glossary) appear to reduce this negative effect.

**Stepped ballasts** have a series of light levels. Typical two-stepped ballasts operate the lamp at nominal 100% and 50% outputs and three-step ballasts operate at nominal 100%, 60% and 30% outputs. The ballast factor (BF) in the manufacturers' literature should be checked to determine the real lamp output at each level. Although they are sometimes grouped with dimming ballasts in catalogues, or called "stepped dimming" ballasts, stepped ballasts only provide multiple level switching and not continuous dimming. The changes in level are sudden and not gradual. Stepped ballasts are less expensive than dimming ballasts, but should not be used in work environments where distraction is an issue. Stepped ballasts can be used with occupancy sensors to provide high and low levels in spaces where total-off is not desired, like some stairs, corridors or restrooms. Like dimming ballasts, stepped ballasts provide lower efficacies at reduced light output.

**Compact fluorescent lamps-ballast systems** take three forms: integral units, such as the standard residential products with a screw-type base; modular plug-in units with a lamp that clips into a ballast-base; and ballasts hard-wired to sockets in a dedicated compact fluorescent lamp (CFL) luminaire. This third system is similar to the hard-wired ballasts used in linear fluorescent fixtures and the same criteria apply. It is recommended that all CFL ballasts used on DDC projects be electronic and hard-wired. The efficacy (lumens per watt) of a CFL lamp-ballast system can be three times better than halogen sources. However, linear fluorescent should be considered in lieu of CFL when it meets other design parameters, since the efficacy of a high performance linear fluorescent system is 45% better than CFL.

### WHAT'S IN THE FUTURE?

New developments in ballast technology, for both fluorescents and HIDs, are concentrating on energy management and system performance. Advanced ballasts are available that have the following features:

- End-of-life sensing ballasts monitor the system and shut off the lamp before failure. These should be used for T5 and smaller fluorescent lamps, and HIDs.
- Multiple-lamp ballasts, which can accommodate three or four lamps per ballast, and typically reduce first cost. Advanced models work efficiently with less than the maximum number of lamps connected.
- Flexible models with circuitry that can be used with more than one lamp type.
- Ballasts that are DALI compatible. DALI (digital addressable lighting interface) is a communication protocol that would allow an entire lighting system to be managed with computer software.

### LIGHTING CONTROLS

Lighting controls serve the dual purpose of enhancing lighting quality and reducing energy consumption. Controls can be simple, e.g. bi-level switching, or complex and integrated into the building's management system. Lighting controls used in DDC projects typically do one, or both, of the following:

- a) Switch lights on or off depending need and occupancy; or
- b) Dim lights for energy conservation, user comfort or specialized applications.

Meeting the New York State energy code, or the U.S. Green Building Council's LEED™ program, requires using some automatic lighting controls, especially when spaces are not occupied. Note that the New York State Energy Code has minimum requirements for lighting controls. (See Appendix A). Selecting appropriate controls is specific to the space and its usage characteristics. Considerations include the following:

- Daylight availability and daylighting design approach
- Usage characteristic and patterns
- Maintenance sophistication and commissioning expectations
- Budget considerations
- Integration with lamp-ballast and fixture selections.

**Daylighting** offers the lighting designer the wonderful opportunity to utilize "free" natural lighting and enhance the experience and perception of the space. It also introduces a powerful light source of variable characteristics that must be coordinated into the lighting strategy. Without controlling the electric lights, there is no way to take economic advantage of daylight.



Photosensor placement is a critical decision for daylight harvesting. (They are about 2" in diameter).

Thus the use of energy saving controls is called “daylight harvesting.” Analyzing the building’s windows and natural light patterns is the first step in designing the electric lighting and a control strategy that will work.

**Usage characteristics and patterns.** Lighting needs are surprisingly specialized in projects built by the Department of Design and Construction. There are office buildings, police and fire stations, libraries, cultural institutions, correctional facilities, daycare centers, shelters, workshops and warehouses. And, as this guide describes, the “rules” change. Lighting controls must be selected for the specific situation – how many hours per day? Are the spaces intermittently occupied? May the occupants operate the controls? Are there changing displays or activities? Will many older people use the space? Do controls have an impact on safety or productivity? A space-by-space review of user patterns and schedules should be part of the lighting strategy planning. See the Design Briefs in this manual for more guidance tailored to particular DDC space types.

**Maintenance sophistication and commissioning expectations.** A control system that is not operating well will not survive – users or maintenance personnel will disable the devices, and the both the savings and the control will be lost. The lighting control system needs to be tailored to the people who are going to use and operate it, suiting their attitudes, sophistication and maintenance expertise. A large building with a permanent maintenance staff will be more successful using a complex, building-wide control strategy than a facility with part-time or transient personnel. Training is very important, regardless of the system sophistication. Additionally, projects that don’t expect extensive construction commissioning of the lighting system should keep lighting controls fairly simple, to ensure that they work well at move-in and are perceived to be beneficial by the users. Controls should be factory-calibrated to the greatest extent possible, and verified or re-calibrated in the field prior to occupancy. This is essential for user-acceptance of any automated lighting controls.

**Budget.** Both operating and initial costs are considerations. Studies have shown that lighting controls quickly pay back their initial investment. Typically this is true for DDC projects even though NYC purchases its power in bulk, and its electric rates are low. Where control strategies must compete for tight construction funds with other priorities, keep in mind that using lighting controls can save money in the HVAC construction budget if the strategies are developed in tandem early in the project, because reducing lighting loads reduces the heat generated, thereby lowering the cooling loads. Using controls to lower the lighting power density allows the engineers to “right-size” the HVAC equipment. Also, for DDC projects, financial assistance, to offset the expense of controls that save energy, may be available from the New York Power Authority (NYPA).

**Integration with lamp-ballast and fixture selections.** The previous lamp and ballast sections explain that not all technologies are compatible with dimming or certain types of switching. Lighting controls need to be part of the comprehensive lighting system, and planned as the overall concept develops.

## LIGHTING CONTROL DEVICES

There is seldom just one way to accomplish the desired control of lighting, and a variety of equipment is available to the lighting designer. (Minimum lighting controls are required by code – see Appendix A). A comprehensive strategy uses several of these control devices in concert, responding to project-specific usage patterns:

- Manual controls
- Switches and switching patterns
- Manual dimmers
- Automatic controls
- Occupancy sensors
- Daylight sensors
- Pre-set controls
- Time controls
- Centralized control management

## Manual Controls

Manual controls allow the users select the lighting levels best suited to their immediate needs. Spaces with variable activities, such as training rooms, multipurpose rooms, or conference centers, generally require manual controls to enable the users to tailor the light for each different activity. Allowing the users to select a “pre-set” lighting scene will generally reduce consumption. (See section below on pre-set controls). Residential-type settings, such as the firehouses or shelters that DDC builds, may also have some appropriate applications for manual controls. With manual controls, occupancy satisfaction is achieved, but the reduction in energy use is unpredictable since it requires individuals to turn off their lights. However, this can be an effective energy strategy with a highly motivated and educated group. For effective use, the controls need to be intuitive and labeled. Note that even with manual controls, the energy codes require an automatic shutoff strategy when spaces are not occupied.

### Manual control advantages

- Simple, intuitive operation (multiple switches must be labeled)
- Low first cost
- Responds to variable lighting requirements and personal preferences

### Manual control disadvantages

- Energy conservation relies on user commitment
- Conflicting preferences in multi-occupant spaces

### Appropriate Uses

- Single occupancy rooms
- Spaces where lighting requirements vary, such as conference rooms, cultural spaces, residences
- Rooms where lighting requirements don't vary and the occupancy is constant, because automatic controls would seldom operate and may not justify the additional expense.

## Switches

Switching strategies can be used in combinations to offer multiple levels of illumination, and multiple mixes of available light sources. In its simplest application, open work areas can have several zones of luminaires, so partially occupied rooms don't need to burn all the lights. **Three-way switches** are typically used in multi-entry and multi-zoned rooms, to facilitate people moving from zone to zone. **Automatic switches**, (or Sentry-type switches that reset to the off position) are appropriate for use with manual-on/automatic-off occupancy sensors. Another strategy is **bi-level switching** — two (or more) light levels within a space can be attained with multi-lamp luminaires, factory pre-wired for easy connection to separate switches, which allows one lamp in each fixture to be turned off, effectively “dimming” the lights. If automatic daylight dimming cannot be installed in a bright space, **separate switching** of fixtures along the window wall is a good idea (orienting the luminaires parallel to the window wall, rather than perpendicular). When several light sources – e.g., overhead luminaires, wall washers, down lights – are present, each type should be switched separately.

## Manual dimmers

Manual dimming is most useful to respond to specific user needs – dimming the conference room lights for AV presentations, raising the light level for the cleaning crew, changing the mood in a cultural space. Manual dimmers can be wall box sliders or hand-held remote controls. Both incandescent and fluorescent light sources are dimmable, and both use less energy when dimmed, although the energy saved is not always proportional to the decrease in light. See the dimming curve in dimming ballast section. Incandescent lamps can be readily dimmed, but fluorescents need specialized electronic dimming ballasts.

## Automatic Controls

Automatic controls provide benefits in user comfort and energy conservation. Automatic controls can deliver reliable energy savings without occupant participation, and when well designed, without their notice. Additionally, they can make adjustments to light levels throughout the day, or in response to specific needs. For safety reasons, light controls are designed to default to full-on when control equipment fails. Re-commissioning is valuable for determining that all the controls operate and save energy as intended.

### Automatic control advantages

- Significant energy conservation possible
- Energy savings are more predictable
- Allows a comprehensive daylighting strategy
- Subtle changes in light levels can be accomplished without occupant participation
- Flexible for accommodating changes in use or occupancy over the moderate/long term

### Automatic control disadvantages

- Controls must be very reliable and predictable for user acceptance.
- May require expertise and/or training of maintenance personnel
- Commissioning is required and adjustments may be necessary when layouts change
- Moderate to high initial cost

### Appropriate Uses

- Dimming of electric lighting to support a daylighting strategy
- Rooms with periods of no occupancy during operating hours (for occupancy sensors), or have regular operating hours (time clocks)
- Support spaces and outdoor areas where usage patterns are predictable



Wall-box occupancy sensor

## Occupancy Sensors

Occupancy sensors turn off the lights when they detect that no occupants are present. The occupancy sensor includes a motion sensor, a control unit and a relay for switching the lights. The sensor and control unit are connected to the luminaire by low voltage wiring, with a transformer stepping down the current. There are four basic types of occupancy sensors, defined by how they detect motion: ultrasonic, passive infrared, acoustic and dual-technology.

**Ultrasonic sensors (US)** utilize a quartz crystal that emits high frequency ultrasonic waves throughout the room. Shifts to the frequency of the wave (called Doppler effect) indicates that there is motion/occupancy in the space. US cover the area continuously, and there are no blind spots in the coverage, e.g., a desk behind a partition. While this makes them effective at detecting occupancy, it also makes them more vulnerable to “false-on” readings caused by traffic in adjacent corridors, and air currents. Therefore they can be most effectively used in combination with manual-on switches (see below), particularly in daylighted spaces. Manual-on prevents false-ons and saves energy by avoiding unnecessary automatic activation when spill-light or daylight is sufficient for the activity.

**Passive infrared sensors (PIR)** respond to the infrared heat energy of occupants, detecting motion at the “human” wavelength. They operate on a line-of-sight basis, and do not detect occupants behind partitions or around corners. They also are less likely to detect motion as the distance increases. Therefore they are useful when a room is small or it is desirable to control only a portion of a space. PIR are more susceptible to false-off readings than false-ons, so tend to be more annoying to occupants than ultrasonic sensors.

**Dual-technology sensors** combine two technologies to prevent both false-offs and false-ons. The most common one uses both ultrasonic and passive infrared sensing to detect occupancy. The sensor usually requires that both US and PIR sense occupancy before turning on. The lights will remain on as long as either technology detects someone. High quality occupancy sensors use the dual technology, since it is more reliable than each of the separate technologies used independently. Dual-technology sensors cost more than sensors using either US or PIR alone.

### Other occupancy sensor features to consider include:

- **Mounting location** – ceiling, high-wall or corner, or wall box. Room size and layout are the major determinants. Ceiling-mounted sensors are the most versatile because their view is less obstructed. Wall box sensors take the place of the room’s wall switch, and they are economical and easy to retrofit. Wall box sensors are appropriate for small, open spaces such as private office, conference rooms, or copy rooms.



- **On-Of settings** – Occupancy sensors can automatically turn on (auto-on) and then automatically turn-off (auto-off). Or, they can require the user to turn them on (manual-on) and then automatically turn off. Manual-on sensors save more energy because the lights don't turn on when the user doesn't need them, such as a sunny day or a quick visit. Most offices, work settings and residences should use them. Auto-on sensors are useful in applications where the users aren't familiar with the layout and switch locations, or where finding a switch would be inconvenient. Examples include: shared restrooms, storage areas, garages, corridors and public use areas.
- **Sensitivity** – Most sensors can be adjusted for the desired degree of activity that will trigger a sensor response. The time-delay (i.e., the time elapsed between the moment a sensor stops sensing an occupant and the time it turns off) can also be selected. The setting can range from 30 seconds to 20 minutes, and the choice becomes a balance between energy conservation, user tolerance, and lamp life. We suggest no less than 15 minutes if controlling instant start ballasts.
- **Multiple level control** – Occupancy sensors are effective for multiple level switching in spaces where full off is not acceptable, but occupancy is not continuous. By using a two- or three-level ballast, or multi-lamp fixtures with lamps wired separately, the lowest level may be allowed to operate at most hours, but when occupancy is sensed, the light level increases. This is a useful energy saving strategy in areas where safety or security requires some light at all times, such as certain enclosed stairs, jail corridors, restrooms, etc. Of the two strategies, multi-level ballasts are more expensive but have the advantage of keeping the lamp warm, reducing early burn-outs caused by frequent switching.

## Daylight Controls

Daylight controls are photoelectric devices that turn off or dim the lights in response to the natural illumination available. Depending on the availability of daylight, the hours of operation and the space function, photoelectrically-controlled lighting can save 10-60% of a building's lighting energy. This can translate into even more financial savings since daylight availability coincides with the hours of the day when peak demand charges apply.

Smooth and continuous dimming is the preferred strategy for automated daylighting controls in offices or other work areas, since it is not distracting to the workers. The photosensor adjusts the light level based on the amount of natural light sensed by sending a signal to the dimming ballast. The less expensive dimming ballasts with minimum settings of 20% of full output are appropriate for daylight dimming. The two strategies, "closed-loop" and "open loop" are based on photo-sensor locations, and the correct sensor location is essential. In a "closed loop" system, the sensor is located above a horizontal surface to detect the light reflecting off that surface from both electric and daylight sources. Since the sensor is reading reflected light, the reflective characteristics of the surface should remain constant. Consequently, sensors are located over a circulation area, rather than a workstation where the reflectivity of the workers clothes or desk-top contents might change. In an "open-loop" system, the sensor is located near the window in such a way to only detect daylight. In both systems, the sensor must not pick up the direct illumination from the electric lights. Sensors can control more than one dimming ballast but the luminaires being controlled must all have a similar orientation to the natural light. For example, trees in front of several windows define a separate lighting "zone." Built-in adjustable time-delay settings are used to slow down the response to rapid changes in natural lighting conditions, providing more steady lighting.

Switching the lights off when sufficient natural lighting is present is a less expensive strategy, but not as acceptable to the occupants. Photosensors are commonly found in outdoor applications – controlling parking lot lighting for example. In buildings, a stepped approach to daylight switching is sometimes employed, in which only some lamps are switched off in multi-lamp luminaires or multi-level ballasts are used. Alternately, daylight switching is used in rooms where continuous occupancy is not common, such as corridors or copy rooms.

The impact of reduced output on lamp color (discussed earlier in this Technologies section) should be taken into consideration when evaluating alternative methods of reducing light output for light level control and energy conservation. Switching adjacent rows of fluorescent lamps retains the color characteristics (as well as the lamp/ballast efficacy), because some of the lamps are off and the rest are operating at full output. Providing multi-levels of light by use of stepped or dimming ballasts results in all of the lamps operating at partial output, and subject to color shifts and reduced efficacy.

### Maintenance dimming

Fluorescent dimming ballasts can also be used to reduce the initial light output to the designed light levels, also known as the “maintained” illuminance. Since lighting systems are over-designed to account for light loss factors (LLF), the initial illuminance can be considerably higher than necessary. A total LLF of 0.7 would result in 142% more light initially. This offers an opportunity to save energy in the first few years of an installation, or when lamps are replaced. “Maintenance dimming” reduces the light output and energy consumption, until the lamp output naturally decreases. The lamps are dimmed less and less until they operate at full output to achieve maintained light levels. Maintenance dimming has lost favor over the years because as a stand-alone strategy it does not offset the cost of dimming ballasts, but it can save energy if dimming ballasts are already utilized for other reasons, such as daylight harvesting. New integrated control systems like DALI (below) are expected to renew the viability of maintenance dimming.

### Load-management or load-shedding dimming

For energy management purposes, facilities might be required to lower their energy consumption during peak electrical demand periods or in emergency situations such as potential brown-outs or black-outs. Instead of turning off lights, fluorescent dimming ballasts would allow the reduction of up to 20% of the power without significant reduction in light output. New integrated control systems like DALI (below) are expected to increase the viability of the controls necessary to accomplishing lighting-related load-shedding.

### Pre-set controls

Switching, dimming or a combination of the two functions can be automatically preprogrammed, so that the user can select an appropriate lighting environment (“scene”) at the touch of a button. Each scene uses a different combination of the luminaires in the room (sometimes dimmed) to provide the most appropriate light for one of several planned activities in that room. A “pre-set controller” and wiring plan organizes this. For example, the occupant of a conference room could select one pre-set scene from a five-button “scene selector” wall-mounted in the room, labeled “Conference”, “Presentation,” “Slide Viewing,” “Cleaning” and “Off”. This allows multiple lighting systems to be installed to meet the varying needs of separate activities, but prevents them from all being used at full intensity for every activity. A pre-set scene should be included for the cleaning crew, which should use the most energy-efficient lights that will allow them to do their work.



Remote control panel for four-scene pre-set control system

### Time Controls

Time clocks are devices that can be programmed to turn the lights on or off at designated times. These are a useful alternative to photoelectric sensors in applications with very predictable usage, such as in parking lots. Simple timers are another option, turning the lights on for a specified period of time, although there are limited applications where this is appropriate, e.g. library stacks. A time controlled “sweep” strategy is sometimes effective: After normal hours of occupancy, most of the lighting is turned off (swept off), but if any occupants remain, they can override the command in just their space. Override controls can be wall switches located within the space, or be activated by telephone or computer. These systems typically flash the lights prior to turnoff, to give any remaining occupants ample time to take action. There are usually more than one sweep operations scheduled after hours, until all lights are turned off.

### Centralized Control Management

Automated Building Management Systems (BMS) are becoming more common in medium and large-sized facilities to control HVAC, electrical, water and fire systems. Incorporating lighting controls is a natural step in efficient management but current BMS systems achieve this with only limited success. In particular, centralized systems are not appropriate for some functions, such as responding instantly, or managing the dimming controls. Some new technological advances that may change this are discussed below.

## Integrated Digital Lighting Controls

The lighting control industry is in a period of rapid change in an attempt to develop control systems that have greater potential for energy savings while also increasing flexibility and occupant satisfaction. The key to achieving such goals is the transition from analog to digital control technologies, a move that is already underway. In addition, the manufacturers of lighting controls, who have typically produced components, are in the process of developing integrated digital lighting control systems. These range from systems designed for homes, or rooms requiring flexible lighting (auditoria, classrooms), to entire buildings.

The transition to digital controls will likely involve two, possibly parallel, steps: Wired digital networks, and wireless (or powerline communication) digital networks. Some examples of these systems are described below, but it should be noted that in five years the control world may be vastly different from these descriptions or predictions.

## Building Management Systems (BMS)

Whole-building management systems utilize standard “protocols” for data communication that were developed for HVAC systems. A “protocol” defines technical performance criteria for system compatibility that is non-proprietary and can be met by many manufacturers. The most common BMS protocols are BACnet or Eschelon. Unfortunately, there are particular operational characteristics unique to lighting (such as the need for instant response, or multiple scene presets) that are not compatible with the current structure of these BMS protocols. Currently, lighting control systems communicate with BMS through an interface, or gateway, so they can give and receive signals (such as BMS time signals, load characteristics, or ballast conditions).

## DALI Control Protocol

DALI stands for Digital Addressable Lighting Interface, and is a protocol for lighting ballast control, rather than a specific product. The purpose of the protocol is to ensure the compatibility of ballast and their controllers, regardless of who manufactures them. The protocol was developed in Europe, and adopted as an international standard in 2002 by the International Electrotechnical Commission (IEC). This protocol currently applies only to digital electronic fluorescent ballasts. Additional DALI protocols and products are under development for other lamp types (incandescent, low-voltage halogen and HID).

DALI was developed for ballasts, and never intended to serve as the communication protocol between lighting control equipment and lighting sensors (occupancy sensors, photosensors, switching controllers). However, draft “enhanced” DALI protocols for control components and sensors were developed under the Public Interest Energy Research (PIER) program in California and are under consideration in the United States by the National Electrical Manufacturers’ Association (NEMA). This and/or other lighting protocols (such as IBECS from Lawrence Berkeley National Labs) may be adopted in the USA in the next few years. In the meantime, manufacturers are providing proprietary control systems that communicate with DALI ballasts.

DALI allows digital dimming ballasts to be wired together (using either line voltage or low voltage wiring) into loops of no more than 64 ballasts each, and networked together to a central computer. Each ballast is given a unique “address” and can be independently controlled in a variety of different ways and linked to any other ballast in the building, regardless of how they are physically wired. In addition, the DALI system can be integrated with a building management system, and communication with the ballasts is “bi-directional”, that is, instructions can be sent to any ballast, and the ballast can report back, giving information about its operation.

The primary advantage of DALI is its flexibility. It can adjust to individual space needs, individual employee preferences, daylight availability, occupancy patterns, lamp lumen depreciation, and load shedding. Although all of these functions can currently be accomplished by conventional lighting controls, the DALI protocol allows any of these characteristics to be modified or ballasts to be re-zoned by computer to respond to future needs, with no physical change to the wiring.

DALI systems are only now being introduced into buildings in North America, and there is a learning curve to overcome before it can be recommended for all buildings. Some “simplified” DALI systems exist that are designed to control one room or a few rooms, and are appropriate for existing buildings or to provide a stepping stone to whole-building integrated DALI systems. These are discussed later. One recent DDC project at the Queens Botanical Gardens has specified a DALI system.

The following pros and cons may shift over time, as whole-building DALI systems gain wider use.

**Applications:**

- New construction is more cost-effective than existing construction, because there are first-cost savings on initial wiring.
- Best for projects where lighting control requirements are complex or changeable over time, like conference rooms, classrooms, auditoria, and flexible office spaces.
- Best for projects where fluorescent dimming is being considered, and future flexibility will actually be utilized.
- Best for projects where a full-time building facility engineer is employed and committed to proactive lighting maintenance.
- Best for projects where a building management system (BMS) is intended.

**Advantages:**

- Individual control of each ballast
- Considerable flexibility in current and future lighting control
- Reduced wiring complexity and cost over systems with comparable control capability
- Identification of lamp and ballast failures, for faster maintenance response
- Allows monitoring and verification of lighting control operation and energy savings
- Can provide sub-metering for multi-tenant spaces
- Increased energy savings due to peak demand period reductions

**Cautions:**

- Requires engineering and IT attention to initial design so that voltage drops and total current of loops and control systems are not exceeded.
- Control systems are currently proprietary, i.e., utilizing only one manufacturer’s control equipment. For example, the DALI controller provided by one manufacturer will require that all dimming pre-set systems and all occupancy sensors be supplied by that same manufacturer. However, these systems are capable of controlling any manufacturer’s ballast that is designed for the DALI protocol.
- Integration with a BMS system still requires a “gateway” to the BMS protocol for commands related to central time control, load shedding, etc.
- Most DALI ballasts are dimming ballasts, so a higher cost will result if dimming is not otherwise needed for the application.
- Increased costs of DALI-compatible equipment. (Costs are expected to decrease in time)
- System randomly assigns ballast addresses. Currently these must be field verified, re-addressed if desired, compiled into databases, and keyed to room numbers or building plans. These databases must be maintained as future changes are made.
- Considerable commissioning and programming time is required for the initial control configurations – this may involve the lighting designer, engineer, owner’s representative and IT personnel and multiple manufacturers. Responsibility and compensation for this considerable labor must be pre-determined. Responsibility of equipment and software manufacturers, and contractors, must be comprehensively specified.
- Control software varies by manufacturer in user-friendliness.
- No single manufacturer takes responsibility for all components. Compatibility between various manufacturers’ components must be verified until such time as all component protocols are adopted.

### **Simplified Dali**

Simpler and stand-alone DALI systems are available that are neither BMS- nor PC-based, nor intended for large building integration. They are designed for residential applications, or for individual spaces such as classrooms, conference or training rooms, where there are multiple functions. Simplified DALI systems still allow the flexibility of individually addressable ballasts, but can be calibrated and programmed through the control unit, typically within the room being controlled or a handheld PALM operating system. This reduces the cost of wiring and maintaining whole-building databases. In a training room for example, multiple “zones” can be established, and multiple scenes can be preset. Both the zones and the scenes can be changed in the future at the controller on the wall, without re-wiring.

### **Wireless Digital Integrated Control Systems**

Several lighting control manufacturers offer wireless products that can control lights and receptacles in residential applications, allow personal control of local office luminaires, streamline the calibration of occupancy sensors or photosensors or perform other control operations. However, these are currently limited in their scope and are proprietary to individual manufacturers. In the next five years or so, one or more wireless or powerline control communication protocols are expected to gain wide acceptance by many manufacturers of integrated lighting controls and components. There are many of these wireless communication protocols currently under development for whole-building systems control (such as Zigbee, a relative of Bluetooth) that may be acceptable for lighting controls, but it is too soon to accurately predict the communications market's outcome.

## GLOSSARY

### LIGHTING TERMS AND DEFINITIONS

**ACCENT LIGHTING** – directional lighting to emphasize a particular object or draw attention to a specific area.

**AMBIENT LIGHTING** – lighting throughout an area which provides general, mainly uniform illumination.

**ASTRONOMICAL TIMECLOCK OR TIMESWITCH** – system capable of providing time-based control with memory program storage, automatic daylight savings adjustment. Astronomic capability for calculating sunrise and sunset based on time, latitude, longitude, and time zones. Timeclock provides adjustable schedules and settings related to 24 hours a day, 365 days per year, holidays, leap year, weekdays, and weekend days.

**BAFFLE** – an opaque or translucent element used to shield a light source from direct view at certain angles, or to absorb unwanted light, or to reflect and redirect light. Baffles are sometimes repeated in an array, such as cross baffles are oriented in one direction.

**BALLAST** – an auxiliary device used with fluorescent and high intensity discharge (HID) lamps to obtain the necessary circuit conditions (voltage, current and waveform) for starting and operating the lamp.

- **Electronic ballast** – constructed using electronic circuitry. High frequency, solid-state.
- **Electronic dimming ballast** – continuous dimming
- **Electronic stepped ballasts** – multiple level output. Not continuous dimming.
- **Magnetic ballast** – constructed using iron core and winding.

**CANDELA (CD)** – the standardized basic unit of luminous intensity, previously defined as an “international candle”, a “new candle” or “candlepower”. One candela emits one lumen per square foot on the inside face of a sphere one foot in radius, or one lumen per square meter on a sphere one meter in radius. Since the area of a sphere is  $4r^2$ , one candela yields 12.57 lumens one foot away, or 12.57 lux one meter away.

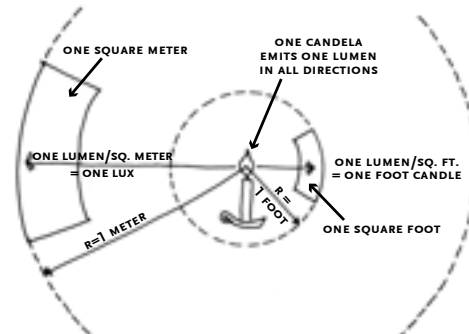

**COEFFICIENT OF UTILIZATION (CU)** – the percentage of lamp lumens leaving a specific luminaire that reach the work surface in a specific room. CU values are influenced by room surface reflectances, size and shape of the room, and location and design of the luminaires.

**COLOR RENDERING** – the effect of a light source on the color appearance of objects in comparison with their appearance under a reference light source.

**COLOR RENDERING INDEX (CRI)** – a scale of values from 0 to 100, indicating how a light source makes a material color look compared to a reference source of the same color temperature. Objects and people viewed under lamps with a high CRI appear more natural.

**COMPACT FLUORESCENT LAMP (CFL)** – a fluorescent lamp using compact folded or spiral tubes. Some models include integral ballast and screw which allows them to be used in place of incandescent lamps, producing the same output with less wattage.

**CORRELATED COLOR TEMPERATURE (CCT)**

– the color appearance of a light source, (in Kelvin), indicating the “warmth” or “coolness” of the color. Sources below 3000 Kelvin appear warm white and yellowish, while sources above 5000 Kelvin appear cool and bluish-white.

**CUT-OFF ANGLE (OF A LUMINAIRE)** – the angle from the vertical at which a reflector, baffle, louver or other shielding device cuts off direct visibility of a light source. It is the complementary angle of the shielding angle.

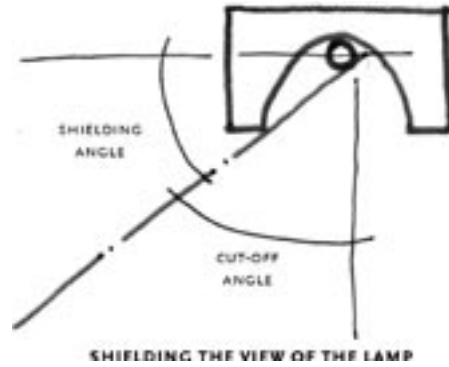

**DALI** – Digital Addressable Lighting Integration (DALI)

protocol. An electronic communication protocol (i.e., technical criteria) for the integrated control of electronic digital fluorescent ballasts. See the Technologies section related to Lighting Controls for a detailed discussion.

**DAYLIGHTING** – lighting strategies that use the sky as a light source, while shielding or reflecting direct sunlight to avoid glare, heat gain or thermal discomfort. Vertical windows and clerestory windows provide side-lighting, and monitors and skylights provide top-lighting.

**DIFFUSER** – a glass or plastic panel, which softens and spreads light rays in a diffuse, non-directional distribution.

**DIMMER** – a control device used to provide variable light output from lamps.

**DISTRIBUTION TYPES (OF LUMINAIRES)**

- **Direct (downlighting)** - a luminaire that distributes all of its light downward.
- **Indirect** – a luminaire that directs its light upward (uplighting) or to the side (wall washing), for the purpose of lighting ceiling or wall surfaces, and/or to provide light to the task after reflection off another surfaces.
- **Direct / indirect (bi-directional)** – a luminaire that distributes its light both directly and indirectly.
- **Diffuse** – a luminaire that distribute its light more or less uniformly in all directions.

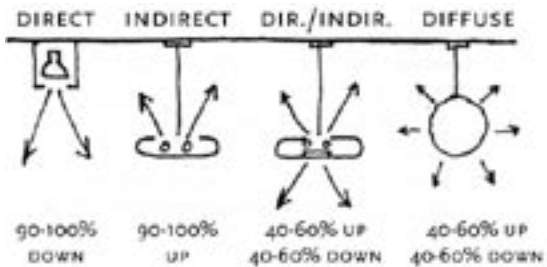

**EFFICACY** – lumens per watt emitted by a light source or a lamp/ballast combination. A yardstick of efficiency. The most informative measure of efficacy is dividing “mean lamp lumens” by “ballast input wattage” listed in lamp and ballast catalogues respectively. See lumens/watt below.

**EFFICIENCY OF A LUMINAIRE** – the percentage of the total light generated by the source that leaves the luminaire in all directions.

**ENERGY** – lighting load (watts) times duration (hours) measured in kilowatt-hours (kWh)

**EXITANCE OR LUMINOUS EXITANCE** – the total luminous intensity emitted, reflected and transmitted from a surface at a point, independent of direction. Exitance is similar to “luminance” except luminance is dependent on direction. Exitance is measured in units of lumens per square foot (lms/sf) previously called footlamberts, or in candelas per square meter. Exitance can be calculated by multiplying the illuminance striking a diffuse reflecting surface times the reflectance of that surface. For example, 50 footcandles (lms/sf) hitting a 30% reflectance surface will emit 15 footlamberts (lms/sf) exitance. 40 footcandles hitting a 70% reflectance surface will emit 28 footlamberts exitance. Even though the illuminance is lower, the latter surface will appear brighter, because of the higher reflectance less light is absorbed by the wall.

**FIXTURE, LIGHT FIXTURE** – a common term for luminaire.

**FLUORESCENT LAMP** – a discharge lamp that produces light by means of electric current through low-pressure mercury gas. The arc produces ultraviolet energy which activates the phosphor coating on the glass bulb to produce light.

**FOOTCANDLE (FC)** – a unit of illuminance in lumens per square foot. The quantity of light (lumens) on one square foot of surface area one foot away from light source of emitting one candela of light intensity in all directions. One footcandle = one lumen per square foot. The metric unit for illuminance is lux. One lux = one lumen per square meter. One fc = 10.76 lux.

**GLARE** – a discomforting or disabling condition, which occurs when a high brightness source contrasts with a low brightness background, making it difficult for eyes to adjust. High brightness alone does not cause glare.

- **Direct glare** – glare resulting from high brightness or insufficiently shielded light sources in the field of view, or from reflecting areas of high brightness. Direct glare includes disability and discomfort glare.
- **Disability glare** – glare resulting in reduced visual performance and visual disability caused by an area of high brightness close to the line of sight. It is often accompanied by discomfort.
- **Discomfort glare** – glare producing discomfort, but not necessarily interfering with visual performance or visibility.
- **Overhead glare** – glare generated above “the normal field of view” that produces discomfort.
- **Veiling reflections** – reflections that partially or totally obscure details by superimposing a patch of reflected brightness (a veil) that reduces task contrast, as in a computer screen or shiny magazine page.

**HIGH INTENSITY DISCHARGE (HID)** – an electronic discharge lamp in which light is produced when an electric arc is discharged and vaporizes metal such as mercury or sodium. Examples are metal halide, high-pressure sodium and mercury lamps.

**HIGH PERFORMANCE (PREMIUM) T8** – a T8 fluorescent lamp with better energy performance than a standard fluorescent lamp, i.e., one that uses less power for the same output, or increased output for the same power. The IESNA does not yet have a standardized definition for these lamps. For the purposes of the DDC requirements, a High Performance T8 is defined as a four-foot fluorescent lamp that, when combined with an electronic ballast, achieves a “mean” lamp/ballast efficacy of 94 lumens per ballast input watt or higher, a CRI of 84 or higher, and a lumen maintenance of 92% or higher at the end of rated lamp life. Lamp lengths other than four-foot shall be High Performance as they become available. For correctional facilities and other difficult-to-maintain locations, High Performance shall also include an extended lamp life (in excess of standard T8 fluorescent lamps), approaching 24,000 hours. (See Technologies section for discussion).

**ILLUMINANCE** – the density of light (in lumens) hitting a surface, per unit of area. Footcandles are lumens per square foot and lux are lumens per square meter. Illuminance can be calculated or measured on any plane, i.e., vertical illuminance being measured on a vertical surface and horizontal illuminance on a horizontal surface. (See also luminance).

**INCANDESCENT LAMP** – a lamp producing light by a filament electrically heated to glowing incandescence.

**LAMP** – a generic term for a complete, man-made light source, with all parts necessary to connect it to electricity, commonly called a light bulb or tube. See Technologies Section for types of lamps and their characteristics.

**LAMP LIFE** – the average period the operation of the components of a lamp before it fails to produce light. Rated Lamp Life is typically the point in time when 50% of a group of lamps have burned out. Manufacturers publish rated lamp life in their catalogues.



**LENS** – a glass or plastic solid element used in luminaires to refract, that is to change the direction and control the distribution of light rays. Lenses can have large or small prisms or be flat, angled or curved, or have combinations of contours, like the plano-convex Fresnel lens. Lenses are designed to be located in a specific relationship to the lamp.

**LIGHT LOSS FACTOR (LLF)** – a multiplier for illuminance calculations that reduces the initial illuminance in order to obtain “maintained” illuminance. LLF takes into account all the factors that depreciate the light over time, such as lamp lumen depreciation (LLD), luminaire dirt depreciation (LDD), room surface dirt depreciation (RDD), ballast losses, temperature losses, etc. It varies by lamp type, luminaire type, ballast type and environmental cleanliness, as well as by assumptions of cleaning and relamping intervals.

**LOW VOLTAGE (LV) LAMPS** – lamps that operate typically at 12 to 24 volts, and require a transformer to step the voltage down from the supply voltage (120 or 227). Low voltage lamps are more compact, and low voltage spot lamps typically produce a tighter beam pattern than standard voltage spot lamp.

**LOUVER** – an array of baffles used to shield light source from direct view at certain angles. The baffles may be used to absorb unwanted light or to control light distribution with different contours such as straight, angled, or parabolic.

**LUMEN (LM)** – the unit of light energy used to specify light output of sources. One lumen is the amount of light that falls on one square foot (or one square meter) of surface area one foot (or one meter) from a source of one candela.

**LUMENS PER WATT (LPW)** – a yardstick for the efficiency of lamps in producing light, i.e., light emitted for watts consumed. Also called “efficacy.”

**LUMINAIRE** – a complete lighting unit consisting of a lamp (or lamps), a housing, and the parts designed to position and protect the lamp, direct light, and connect the lamp to a power supply. Commonly called a light fixture.

**LUMINANCE** – Luminance is the intensity of light reflected off surfaces, transmitted through optical media, or emitted by a source. Luminance is perceived by humans as the “brightness” of surfaces reflecting off light, or the brightness of light surfaces. Luminance is measured in a particular direction, in contrast to “luminous exitance,” which is the same as luminance except independent of direction. Measured in units of lumens/square foot (outdated) or candelas/square meter (current). Luminance is a function of illuminance hitting a surface, reduced by the reflectance, specularity, refraction or transmittance of the surface material. Lighting software such as AGI or LumenDesigner typically calculate “luminous exitance” which is the same as luminance except independent of direction, i.e., assumes a totally diffuse surface. For interior environments, existances and exitance ratios are roughly equivalent to luminance and luminance ratios as long as the surfaces are not glossy or shiny.

**LUMINANCE RATIOS** – the ratio between two different luminances, which determines the degree of contrast. Low ratios (1:1) describe the most uniform while higher ratios (1:30+) describe higher contrast and potential glare conditions. It is an essential metric for lighting comfort and quality. Appropriate luminance ratio standards are established by the IESNA for different space types and functions, and such standards are often expressed as the ratio of minimum to maximum luminances, or average to minimum luminances. Only when surface reflectances are almost identical can the ratio between illuminances (light hitting the surfaces) be used as a reasonable indicator of the uniformity of non-emitting surfaces in a scene. “Exitance ratios” provided by lighting calculation software are acceptable substitutions for luminance if reflecting surfaces are not shiny.

**LUX** – the metric unit of illuminance, measured in lumens per square meter. One lux = .0929 footcandles. Published light level requirements usually round off the value of one lux to a tenth of a footcandle, so that 150 lux are equivalent to 15 footcandles.

**MAINTAINED ILLUMINATION LEVEL** – initial illuminance from luminaires adjusted by a light loss factor (LLF). Losses include depreciation of lamp output by aging, effects of dirt accumulation on luminaire surfaces and room surfaces, ballast losses, and other light degrading factors.

**QUALITY (OF LIGHTING)** – positive attributes of a lighting design that contributes to visual comfort and long term performance, such as uniformity, appropriate luminance ratios, high color rendering etc., and the reduction of negative factors such as glare, flicker, distracting shadows, etc.

**REFLECTOR** – a contoured surface, usually behind a lamp, used to direct light from the lamp in a specific way. The light distribution pattern is dependent on the shape, reflectivity and specularity of the reflector material.

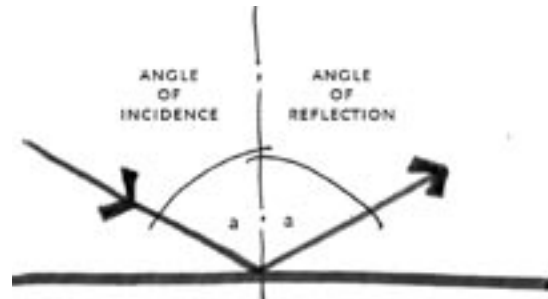

**ANGLE OF INCIDENCE = ANGLE OF REFLECTION FOR SPECULAR AND SEMI-SPECULAR SURFACES**

**REFLECTANCE** – the overall percentage of light reflected off a surface, independent of direction. For example, a matte white wall and a polished metal wall can both have a high reflectance of say, 85%. A matte black floor and a polished black floor will both have a low reflectance of say, 5%.

**REFLECTION** – the way a surface returns light, based on the surface texture, such as a specular reflection or diffuse reflection. (See sketch). A surface with a diffuse reflection will always appear more uniformly bright than a shiny surface, which tend to appear darker overall, except for a bright lamp image.

**Reflective surface types:**

- **Matte surface** – a non-glossy, dull surface from which reflected light is totally diffused, or scattered.
- **Eggshell, semi-gloss, semi-specular** – an essentially diffuse surface that may be slightly shiny or metallic, but has a brushed or textured finish so that a lamp image can never clearly be seen.
- **Specular surface** – a shiny, polished or mirrored surface, or slightly textured surface, that clearly reflects a lamp image. Some popular brushed metals, like stainless steel #4, are essentially specular. A ray of light striking a specular surface will be reflected away from the surface at the same angle as it hits the surface, i.e., the angle of reflection equals the angle of incidence.

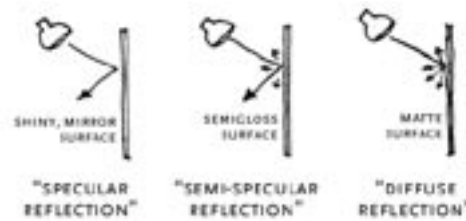

**SHIELDING** – a general term that includes all devices used to block, diffuse, or redirect light rays, including baffles, louvers, shades, diffusers, and lenses.

**SPACING CRITERION (SC)** – a value assigned to a specific luminaire by its manufacturer, used to determine the maximum center to center spacing that will still yield a uniform distribution of illuminance. Also called spacing-to-mounting-height-ratio (S/MH). After the mounting height is determined (see sketch), it is multiplied by the luminaire’s spacing criterion (SC) value to determine the maximum spacing. Unfortunately, the SC does not take into account partial-height furniture partitions. The luminaire spacing must be reduced in such spaces to avoid shadows and non-uniformity, based on calculations or mockups.

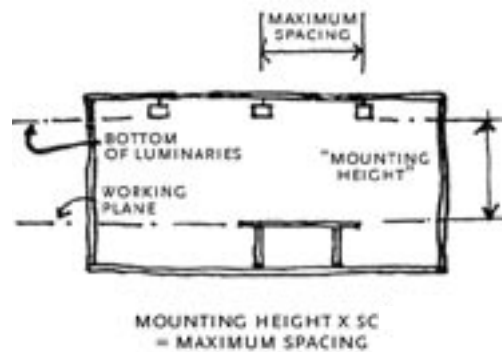

**SPECULAR AND SEMI-SPECULAR** – a specular surface is shiny, high-gloss or mirror-like, and light reflected off of such a surface provides a specular reflection, where the angle of reflection equals the angle of incidence. From certain angles, a clear lamp image is visible in a specular surface. A semi-specular surface is one that is partially textured, brushed or semi-gloss, so that light reflected off of it retains its directional characteristics, but some of the light is diffused.

**TASK LIGHTING (SUPPLEMENTARY LIGHTING)** – lighting directed to a specific surface or area that supplements the ambient light to provide the illumination necessary for visual tasks. Task luminaires are usually controlled by the user. Articulated task lights are adjustable in three planes.

**TUNGSTEN-HALOGEN (PREVIOUSLY QUARTZ-HALOGEN) LAMP** – incandescent light source with a quartz or other glass capsule enclosing the tungsten filament and containing halogen gas. This construction allows the filament to operate at a higher temperature and provides higher efficiency, whiter light, and longer life than standard incandescent lamps.

**TRANSMITTANCE** – the percentage of light that passes through a material. The nature of the transmittance depends on the clarity or opacity of the material. Transmitting materials can be transparent or translucent. A surface that allows no light transmission is opaque. (See diagram)

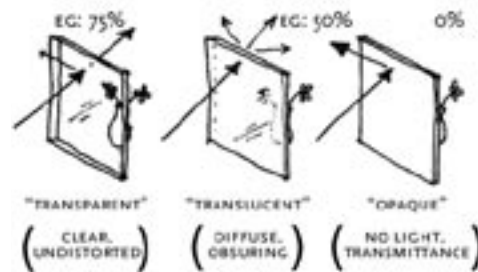

**TRANSFORMER** – an electrical device that alters voltage. Often used to step down voltage for low voltage lamps. Larger transformers can supply circuits with many lamps or luminaires.

**VEILING REFLECTIONS** – a form of reflected glare that partially or totally obscures details by reducing the contrast of an object or character against its background. The effect is that of a haze or “veil” cast over part of the task, obscuring the image behind, and is most noticeable in a glossy magazine or a computer screen. (See Glare)

**VISUAL TASK** – those details and objects, which must be seen for the performance of a given activity, including the immediate background of the details or objects. Examples of visual tasks are reading characters on a page, seeing lines for a CAD drawing on a computer screen, or seeing the patterns of light and shadow that define facial features.

**WALL WASH** – a form of indirect lighting where the wall is lighted. Uniform wall washing is typically achieved by locating wall-wash type luminaires (with an asymmetrical distribution) two to four feet from wall plane, usually spaced the same dimension on center as the distance from the wall. A “grazing” wall wash effect is achieved by locating the luminaires closer to the wall, to emphasize texture. A slot wall washer is a continuous luminaire mounted in the ceiling at the junction of the wall.

**WORK SURFACE OR WORKING PLANE** – the plane at which visual work usually is performed, and for which illuminance is specified and measured. Unless otherwise indicated, this is assumed to be at desk height, that is, a horizontal plane 30 inches above the floor.

## REFERENCES & INTERNET RESOURCES

### DESIGN AND TECHNOLOGY GUIDES

**Advanced Lighting Guidelines.** New Buildings Institute. 2003  
Available at <http://www.newbuildings.org/lighting.htm>

**American National Standard Practice for Office Lighting.** (ANSI/IESNA Recommended Practice) RP-1-04. Illuminating Engineering Society of North America, 2004.  
Available at <http://www.iesna.org>

**ANSI/ASHRAE/IESNA Standard 90.1-1999 / 2001 / 2004**  
Available at <http://www.ashrae.org> or <http://www.iesna.org>

**Choosing Light Sources for General Lighting.** (IESNA Design Guide) DG-10-98. Illuminating Engineering Society of North America, 1998.  
Available at <http://www.iesna.org>

**Daylighting.** (IESNA Recommended Practice) RP-5-99. Illuminating Engineering Society of North America, 1999.  
Available at <http://www.iesna.org>

**Daylighting Design - Smart and Simple.** EPRI TR-109720. Electric Power Research Institute, 1997.  
Available at <http://www.iesna.org>

**Daylighting in Buildings: A Source Book on Daylighting Systems and Components.**  
International Energy Agency, 2000.  
Available at <http://gaia.lbl.gov/iea21/>

**DELTA Portfolios and DELTA Snapshots.** Lighting Research Center  
Available at <http://www.lrc.rpi.edu/programs/delta/index.asp>

**Design Guide for Warehouse Lighting.** (IESNA Design Guide) DG-2-92. Illuminating Engineering Society of North America, 1992.  
Available at <http://www.iesna.org>

**Energy Design Resources** (website) Administered by four California utilities. Includes technology summaries for daylighting and electric lighting.  
Available at <http://www.energydesignresources.com>

**Guideline on Security Lighting for People, Property, and Public Spaces.** (IESNA Guideline) G-1-03. Illuminating Engineering Society of North America, 2003.  
Available at <http://www.iesna.org>

**The IESNA Lighting Handbook Reference & Application, 9th Edition.** Illuminating Engineering Society of North America, 2000.  
Available at <http://www.iesna.org>

**KnowHow Lighting Guides (Highbay Industrial, Lowbay Industrial, Office, Warehouse Skylight, Classroom, Retail, and Retail Skylighting).** DesignLights Consortium  
Available at <http://www.designlights.org/guides.html>

**The Landscape Lighting Book, Second Edition.** Janet Lenox Moyer, 2005. John Wiley & Sons, Inc

**Lighting Controls: Patterns for Design.** EPRI-TR-107230. Electric Power Research Institute, 1996.  
Available at <http://www.iesna.org>

**Lighting for Educational Facilities.** (IESNA Recommended Practice) RP-3-00. Illuminating Engineering Society of North America, 2000.  
Available at <http://www.iesna.org>

**Lighting for Exterior Environments.** (IESNA Recommended Practice) RP-33-99. Illuminating Engineering Society of North America, 1999.  
Available at <http://www.iesna.org>

**Lighting for Industrial Facilities.** (ANSI/IESNA Recommended Practice) RP-7-01. Illuminating Engineering Society of North America, 2001.  
Available at <http://www.iesna.org>

**Lighting for Parking Facilities.** (IESNA Recommended Practice) RP-20-98. Illuminating Engineering Society of North America, 1998.  
Available at <http://www.iesna.org>

**The Museum Environment (Butterworth Series in Conservation and Museology).** Second Edition Garry Thomson. Butterworth 1986.  
ISBN 0-408-01536-5

**National Lighting Product Information Program (NLPIP) Publications: NLPIP Specifier Reports, NLPIP Lighting Answers, and NLPIP Technical Guides. Lighting Research Center.**  
Available at <http://www.lrc.rpi.edu/programs/nlPIP/index.asp>

**High Performance Building Guidelines.** New York City Department of Design & Construction  
Available at <http://www.ci.nyc.ny.us/html/ddc/html/ddcgreen/>

**Outdoor Lighting Code Handbook, VI.14.** International Dark-Sky Association, 2002.  
Available at <http://www.darksky.org/ordsregs/lchintro.html>

**Outdoor Lighting Pattern Book.** Russell P. Leslie and Paula A. Rodgers. McGraw-Hill, 1996. ISBN 0-07-037188-1  
Available at <http://www.iesna.org>

**Planned Indoor Lighting Maintenance.** (IESNA/NALMCO Recommended Practice) RP-36-03. Illuminating Engineering Society of North America, 2003.  
Available at <http://www.iesna.org>

**Roadway Lighting** (ANSI/IESNA Recommended Practice) RP-08-00. Illuminating Engineering Society of North America, 2000.  
Available at <http://www.iesna.org>

**Selection of Photocontrols for Outdoor Lighting Applications.** (IESNA Design Guide) DG-13-98. Illuminating Engineering Society of North America, 1998.  
Available at <http://www.iesna.org>

**Technical Memorandum on Light Trespass: Research, Results, and Recommendations.** IESNA TM-11-00. Illuminating Engineering Society of North America, 2000.  
Available at <http://www.iesna.org>

## CODES AND STANDARDS AND TESTING

### **Standards for Adult Local Detention Facilities, Third Edition 1991 2004 Standards Supplement for Adult Local Detention Facilities**

American Correctional Association  
<http://www.aca.org>

### **Americans with Disabilities Act (ADA) ADA Standards for Accessible Design**

U.S. Department of Justice  
<http://www.usdoj.gov/crt/ada/adahom1.htm>

**California Energy Commission Title 24, Section 6, 2001.** California Energy Commission  
<http://www.energy.ca.gov/title24/>

**ETL Testing Laboratories** (formerly Edison Testing Laboratories)  
<http://usa.etlsemko.com>

**International Energy Conservation Code 2003.** International Code Council  
<http://www.iccsafe.org/>

**National Electric Code 2002 (NFPA 70).** National Fire Protection Association.  
<http://www.nfpa.org>

**New York City Department of Buildings Home Page**  
<http://www.nyc.gov/html/dob/home.html>

**New York City Electrical Code**  
<http://www.nyc.gov/html/dob/html/elcode2.html>

### **New York State Energy Code:**

Energy Conservation Construction Code of New York State (ECCCNYS) 2002  
<http://www.dos.state.ny.us/code/energycode/nyenergycode.htm>  
To contact the New York Department of State Codes: e-mail to [codes@dos.state.ny.us](mailto:codes@dos.state.ny.us) or phone (518) 474-4073. To purchase ECCCNYS code contact ICBO at <http://www.icbo.org> or by telephone at 800-284-4406.

**New York State Lighting and Power Compliance Guide** (free download)  
Available at <http://www.dos.state.ny.us/code/energycode/commercial/nyenergycode.htm>

**New York State COMcheck-EZ software and instructions** (free download)  
Available at <http://www.energycodes.org>

**Underwriter's Laboratory**  
<http://www.ul.com>

## CALCULATION SOFTWARE

**AGI.** Lighting Analysts.

Available at <http://www.agi32.com/>

**AGI-Light.** Lighting Analysts.

Available at <http://www.agi32.com/>

**Aladan.** GE Lighting Systems.

Available at <http://secure.ge-lightingsystems.com/>

**Genesys II.** Genlyte Thomas.

Available at <http://www.genesysii.com/>

**LitePro 2.0.** Hubbell Lighting, Inc.

Available at <http://columltg.tempdomainname.com/litepro/>

**Luxicon.** Cooper Lighting.

Available at <http://www.cooperlighting.com/etools/luxicon/>

**Lumen Designer 2004.** Lighting Technologies.

Available at <http://www.lighting-technologies.com/>

**Radiance Synthetic Imaging System.** Lawrence Berkley National Labs.

Available at <http://radsite.lbl.gov/radiance/>

**Skycalc.** Energy Design Resources.

Available at <http://www.energydesignresources.com/resource/129/>

**Visual 2.3.** Acuity Brands Lighting.

Available at <http://www.lithonia.com/software/Lightware7/Visual/>

**Viz (incorporates Lightscape).** AutoDesk.

Available at <http://usa.autodesk.com>

## ORGANIZATIONS AND ASSOCIATIONS

### **American National Standards Institute (ANSI)**

<http://www.ansi.org/>

### **American Society of Heating, Refrigerating and Air-Conditioning Engineers (ASHRAE)**

<http://www.ashrae.org>

### **Electrical Power Research Institute (EPRI)**

<http://www.epri.com>

### **Illuminating Engineering Society of North America (IESNA)**

<http://www.iesna.org>

### **Lamp Recycling**

<http://www.lamprecycle.org>

### **LEED™ Leadership in Energy & Environmental Design**

United States Green Building Council

<http://www.usgbc.org/>

### **New York City Department of Design & Construction Home Page**

<http://www.ci.nyc.ny.us/html/ddc/>

### **New York City Department of Design & Construction Office of Sustainable Design Home Page**

<http://www.ci.nyc.ny.us/html/ddc/html/ddcgreen/>

### **New York Power Authority**

<http://www.nypa.gov/>

### **New York State Energy Research and Development Authority**

<http://www.nyserda.org/>



The image shows an interior space with a vibrant red wall. A window with a dark frame is set into the wall. Below the window, a light-colored tiled floor is visible. A dark, possibly black, structure is partially visible in the lower right corner. The ceiling is a neutral, light color. A dark green rectangular box is overlaid on the upper part of the image, containing the word 'APPENDICES' in white, uppercase letters.

## APPENDICES

## APPENDIX A ENERGY CODE COMPLIANCE

### ABBREVIATIONS (SEE REFERENCES FOR MORE DETAIL)

<b>NYS ENERGY CODE</b>	Energy Conservation Construction Code of the State of New York
<b>STANDARD 90.1</b>	ANSI/ASHRAE/IESNA Standard 90.1 Energy Standard for Buildings Except Low-Rise Residential Buildings
<b>ANSI</b>	American National Standards Institute
<b>ASHRAE</b>	American Society of Heating, Refrigerating and Air Conditioning Engineers, Inc.
<b>IESNA</b>	Illuminating Engineering Society of North America
<b>IECC</b>	International Energy Conservation Code
<b>LEED™</b>	Leadership in Energy & Environmental Design rating system.

### NYS ENERGY CODE REVISIONS

1. The NYS Energy Code current at the time of this publication took effect in June 2002. It is based on the IECC 2000 model code, with additional control requirements added by NYS. It allows the alternative of using the 1999 version of Standard 90.1
2. The NYS Energy Code is under revision, and the changes are likely to become effective in early 2007. The revised 2007 code conforms for the most part with the IECC 2003 model code, and allows the use of ASHRAE/IESNA Standard 90.1-2001 as an alternative. The IECC model code will also be revised in 2006, and will reference Standard 90.1-2004 as an alternative. The NYS Energy Code is expected to follow suit and be revised again in the next few years. The watts per square foot lighting allowances in these proposed codes are significantly changed – on average, they are 30% lower than the current codes.
3. Since projects presently in design phases must meet the energy code that will be in effect when that project files for a building permit, project teams should keep abreast of the status of code changes posted on the New York State government web site. The NYS Department of State website is [www.dos.ny.us](http://www.dos.ny.us). Select “Building Codes” and select “Division of Code Enforcement”, as well as “Energy Codes” for progress charts or other news items. You can also contact the New York State Department of State Codes at (518) 474-4073 or by e-mail at [codes@dos.state.ny.us](mailto:codes@dos.state.ny.us).
4. Copies of all relevant codes and standards are available for purchase at the various organizational web sites. Some assistance is available in free downloads, including the NYS Lighting and Power Compliance Guide, and simple compliance software (for the prescriptive path only) called COMcheck-EZ. (See References).

### TWO METHODS OF LIGHTING COMPLIANCE - PRESCRIPTIVE AND PERFORMANCE

Using either the NYS Energy Code or Standard 90.1, the team can choose one of two “paths of compliance”:

1. **Prescriptive path** (also called “component compliance”): The lighting design must comply with individual prescriptive requirements for each component of the building. The lighting component section includes minimum control requirements, maximum connected load (based on watts per square foot values) for the building interior lighting and other requirements outlined below. The prescriptive path of either the NYS Energy Code (Section 805) or Standard 90.1 (Chapter 9) may be used.
2. **Performance path** (also called whole-building performance): All the energy systems of a building are analyzed together by energy-simulation computer software such as DOE-2. The energy costs of a “base case” building, called the Standard design or Budget design, are determined. The power allowance determined under the prescriptive path is used to assume the lighting loads for the base case only. The energy consumption and costs of the intended whole-building design (called the Proposed design), is then simulated. The energy costs of the Proposed design must not exceed the energy costs of the Standard or Budget design. The performance path of either the NYS Energy Code (Section 806 – Total Building Performance), or Standard 90.1 (Chapter 11 – Energy Cost Budget Method) may be used. In the case of Standard 90.1, the “mandatory” requirements of the prescriptive lighting path (minimum controls, minimum exterior efficacy) must always be met, even if the whole-building performance path is used.

## TWO STEPS: CRITERIA, THEN COMPLIANCE

Each project, (using either NYS Energy Code or Standard 90.1) must first establish the energy criteria for that project, then later demonstrate that the actual design complies with the criteria. For example, to determine the total Interior Power Allowance for the project using the space-by-space method, the Lighting Power Density (W/sf) is selected for each space type, during the Schematic Design Phase. This value is multiplied by the square footage of each space type, and the sums are added together to create the Interior Power Allowance. The design team may distribute this power as it wishes. When demonstrating compliance of the Construction Documents compliance, it is NOT necessary that the lighting for any space type comply with the W/sf values to establish the Allowance. It is only necessary that the total connected lighting load of the building does not exceed the total Interior Power Allowance.

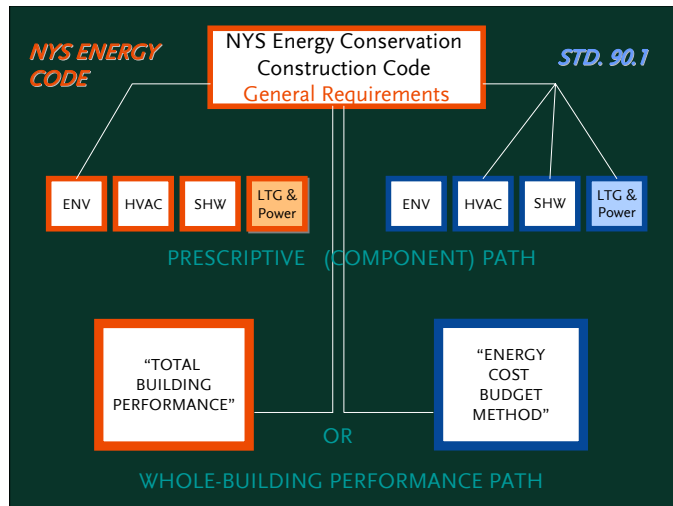

### 1. STEP ONE: ESTABLISH PROJECT LIGHTING CRITERIA:

- a) Establish minimum **controls** requirements and other mandatory requirements relevant to project;  
**AND**
- b) Establish maximum **interior allowances** for power or energy for project;
  - Calculate Interior Power Allowance for building (prescriptive path), **OR**
  - Calculate energy cost performance of the whole building "base-case" Standard Design or Budget Design (performance path)**AND**
- c) Establish criteria for exterior lighting.
  - Note minimum efficacy (lumens/watt) criterion for exterior light sources **AND**
  - Calculate Exterior Power Allowance for building exteriors (Standard 90.1 only)

### 2. STEP TWO: DEMONSTRATE COMPLIANCE WITH PROJECT LIGHTING CRITERIA:

- a) Demonstrate compliance with minimum requirements for controls and mandatory requirements;  
**AND**
- b) Demonstrate compliance with interior power or energy criteria;
  - Calculate actual connected lighting load of project. Must not exceed Interior Power Allowance (prescriptive path) **OR**
  - Calculate energy or cost performance of whole building. Must be better than the base-case (performance path)**AND**
- c) Demonstrate compliance with exterior lighting criteria.
  - Show compliance with efficacy criteria (lumens/sf) **AND**
  - Show compliance with exterior lighting power allowances (Standard 90.1 only)

## MIX AND MATCH

1. Under the prescriptive path, the NYS Energy Code allows the use of Standard 90.1 for any individual component or all the components. For example, the team can choose to comply with Electrical (including lighting) and HVAC components using Standard 90.1 and Envelope and Service Hot Water components using the NYS Energy Code prescriptive requirements, or any other combination.
2. Under the performance path, the NYS Energy Code allows the use of Standard 90.1 performance path as an alternative.
3. There is no need to mix or match between the prescriptive and performance paths. The use of the whole-building performance path replaces the need for component compliance under the individual prescriptive paths. When creating a 'base case' using the performance path of either the NYS Energy Code or Standard 90.1, the base case assumptions must be made using the prescriptive limits in the same document. However, it is only necessary to demonstrate (through energy simulation software) that the total energy performance of the actual building design does not exceed the total energy performance of the base case. Aspects of the actual design may exceed individual prescriptive limits, as long as the building as a whole complies.
4. The option to use Standard 90.1 for the prescriptive or performance compliance paths does not relieve the team from complying with all the other provisions of the NYS Energy Code, i.e., Sections 1 through 6.

## WHY SELECT PRESCRIPTIVE VERSUS PERFORMANCE?

1. Prescriptive methods are easier to calculate and demonstrate, but are also more restrictive.
2. The whole-building performance method takes into account integration of energy systems and technologies or strategies that are not covered under the prescriptive method. For example a particular project may exceed both the window-to-wall ratio and the lighting watts/sf limitation determined by the prescriptive requirements; yet by taking into consideration high-performance glazing and the reduced hours of energy consumption due to advanced daylighting controls, the whole building can still comply.
3. The performance method is necessary to obtain credits for energy savings under the LEED™ rating system.

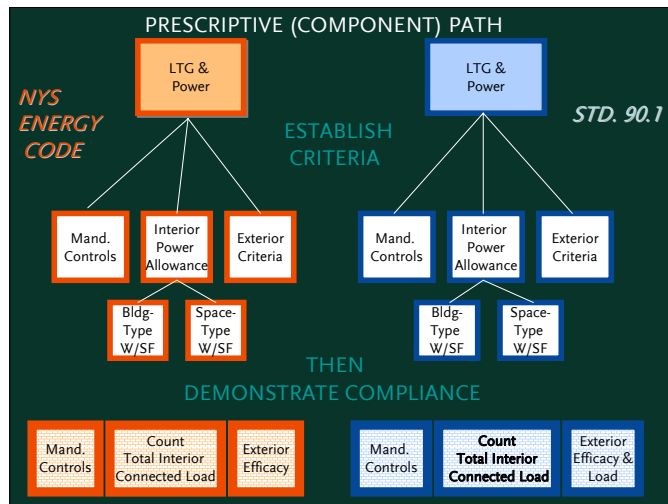

## WHY SELECT STANDARD 90.1 VERSUS NYS ENERGY CODE?

1. Standard 90.1 has more exemptions than the NYS Energy Code, most notably exemptions for theatrical lighting and plant survival lighting.
2. NYS Energy Code has slightly more stringent lighting control requirements such as light reduction controls or bi-level switching. However, DDC teams are encouraged to consider a greater level of lighting control than that required by either NYS Energy Code or Standard 90.1.
3. The LEED™ rating system requires compliance with Standard 90.1 as a pre-requisite, then uses Standard 90.1 as the standard against which energy savings are measured. The applicable version (year) of Standard 90.1 may change from one LEED™ program to another.

## PRESCRIPTIVE PATH DETAILS

1. There are two methods of calculating an Interior Lighting Power Allowance, using tables of watts per square foot values (called Lighting Power Density, or LPD values):
  - Building type method: using a single watts per square foot value for a building type, multiplied by the air conditioned floor area of the building; **OR**
  - Space-by method: multiplying the watts per square foot values for individual space types by their respective areas, and adding them all together.

The building type method is simpler, but typically yields a more stringent value than the space-by-space method. Tables with watts per square foot values are available in both the NYS Energy Code and Standard 90.1. The values are similar between the code and the standard, but are not identical.

2. However the Interior Lighting Power Allowance is determined, the actual connected lighting load of the actual project interior must not exceed the total Interior Power Allowance. The space-by-space watts per square foot values are only for the purpose of establishing the total Power Allowance. Once that is done, there is no requirement to comply with those individual values. Trade-offs are acceptable, so designers can use more watts in one space type and less in another. It is only necessary to comply with the whole building power allowance.
3. All permanently attached luminaires, and track-mounted luminaires must be counted as part of the connected load when determining compliance. Due to the increased stingency of the new codes, portable lighting equipment, including decorative torchieres, portable task lights and undercabinet lights may not have to be counted in lighting compliance of the revised Standard 90.1-2004. However, such luminaires should utilize fluorescent or compact fluorescent lamps, or other energy efficient light sources with lamp/ballast efficacies greater than 45 lumens/watt.

## EXTERIOR LIGHTING REQUIREMENTS

The NYS Energy Code requires exterior light sources to provide at least 45 lumens per watt, except for low voltage landscape lighting. It has no exterior Power Allowance. Standard 90.1 requires exterior light sources to provide at least 60 lumens per watt except for small fixtures (rated at less than 100 watts) or those controlled by a motion sensor.

In addition, Standard 90.1 limits the connected power of lights used for entries, exits and façade lighting, based on a table of values. This table was expanded to include parking lots and other areas in the 2004 version. (See Building Exterior Design Brief for a summary chart.) Some exterior lighting is exempted from the exterior power limit if it is separately controlled, such as lighting for specialized transportation buildings, public and historic landmarks, and advertising signage.

## LIGHTING CONTROLS

Both the NYS Energy Code and Standard 90.1 have minimum requirements for lighting controls. Again, these are similar but not identical. Since lighting controls have such a large influence on energy consumption, the design team should strive to provide a control system that exceeds the minimum requirements of the codes. The chart below attempts to summarize the control requirements.

## CAVEAT

The energy code information provided throughout this document is offered as assistance to the design teams, but should not be used to replace the information in the actual code or standards documents, some of which are in the process of revisions. Whichever code or standard is selected, the design team should carefully read the actual language as published by NYS or ASHRAE, and request interpretations or clarifications from those bodies, and not from DDC.



REQUIRED BY ALL CODES	REQUIRED BY SOME CODES	Standard 90.1 1999 + 2001	Standard 90.1 2004	NYS Energy Code 2002	Proposed NYS Energy Code 2007
<b>EXTERIOR LIGHTING CONTROLS</b>					
<p><b>Automatic/Photocell Controls</b> - Astronomical time switching or photocell controls shall be provided for all exterior lighting not intended for 24-hour operation. Automatic time switched shall have a combination seven-day and seasonal daylighting program schedule adjustment. Controls shall be capable of automatically turning off the exterior lighting when sufficient daylight is available or when lighting is not required during nighttime hours</p>		√ 12	√ 12	√	
	Time switch can retain programming for at least 4 hours with a loss of power.			√	
	Time switch can retain programming for at least 10 hours with a loss of power.	√	√		
	If equipped with an independent control device, certain exterior applications are exempt from meeting the overall power allowance for exterior lighting.	√13-15, 22	√13-22	√	√

Control Notes

- 1 Except areas less than 250 sf - NYS
- 2 Except spaces where lighting is intended for 24 hour operation -Standard 90.1 1999, 2001, 2004
- 3 Except areas designated as security or emergency areas that must be continuously lighted. -NYS
- 4 Except stairways and corridors that are elements of the means of egress -NYS
- 5 Except spaces where automatic shutoff would endanger safety or security of the room or building occupants - Standard 90.1 2004
- 6 Except lighting where patient care is rendered. Standard 90.1 2004
- 7 EX
- 8 Except emergency lighting automatically off during normal building operation -Standard 90.1 1999, 2001, 2004
- 9 Except areas that are controlled by an occupancy sensor, or have only 1 luminaire, or corridors, storerooms, restrooms or public lobbies -NYS
- 10 Except dwelling units
- 11 Except guest rooms
- 12 Except exterior lighting for covered vehicle entrances or exits from buildings or parking structures for required safety, security and eye adaptation -Standard 90.1 1999, 2001, 2004
- 13 Exterior specialized signal, directional and marker transportation lighting - Standard 90.1 1999, 2004
- 14 Exterior light used to highlight features of public monuments and r
- 15 Exterior advertising signage and directional signage - Standard 90.1 1999, 2001, 2004
- 16 Exterior lighting integral to eq
- 17 Exterior lighting for theatrical purposes including performances, stage, film production and video production - Standard 90.1 2004
- 18 Exterior athletic playing areas - Standard 90.1 2004
- 19 Exterior temporary lighting - Standard 90.1 2004
- 20 Exterior industrial production, material
- 21 Exterior theme elements in theme/amusement parks - Standard 90.1 2004
- 22 See Standard 90.1 for additional exemptions
- 23 Except areas that use less than 0.6 W/sf (NYS)
- 24 Except malls, arcades, auditoriums, single tenant retail, industrial, when a) captive
- 25 Except retail stores, malls, restaurants, grocery stores, churches and theaters.(NYS 2007)
- 26 Except fluorescent lamps less than 30 W each (Standard 90.1 1999, 2001)
- 27 Surface or pendant-mounted luminaires within 1 foot end-to-end shall also be tandem wired. (NYS 2007)

## APPENDIX B

DDC requires design professionals to demonstrate that the final design complies with the New York State Energy Conservation Code (see DDC Design Consultant Guide, August 2003). This form and backup forms or documentation must be submitted to DDC prior to submittal for building permit.

### DDC “DECLARATION OF NYS ENERGY CODE COMPLIANCE” FORM

- This project is exempt from all requirements of the Energy Conservation Construction Code of New York State. (Attach explanation).
- This project is not exempt from the Energy Conservation Construction Code of New York State.

The version of the NYS Energy Code in effect as of the date of this project’s submittal to the building department is: [2002] or [ \_\_\_\_\_ ] date.

#### DDC COMPLIANCE STATEMENT

“The proposed lighting design represented in these documents is consistent with the building plans, specifications and other calculations submitted with this 100% Construction Documentation submission to the NYC Department of Design and Construction. The proposed lighting system has been designed to comply with the lighting-related sections of the New York Energy Code, using the compliance path checked below.”

ARCHITECT OF RECORD	COMPANY NAME	PRINT NAME	SIGNATURE	DATE
ELECTRICAL ENGINEER OF RECORD	COMPANY NAME	PRINT NAME	SIGNATURE	DATE
LIGHTING DESIGNER	COMPANY NAME	PRINT NAME	SIGNATURE	DATE

The New York State Energy Conservation Code allows several paths of compliance for commercial buildings: Please indicate which path has been selected for this project:

- Chapter 8, Sections 801 and 805 (Lighting), NYS Energy Code. [Attach backup\*]
- Chapter 8, Sections 801 and 806 (Total Building Performance), NYS Energy Code. [Attach backup\*]
- Chapter 7, NYS Energy Code allows lighting compliance to be demonstrated in accordance with the applicable provisions of ASHRAE/IESNA/90.1. This project complies with the following version (verify with NYS Energy Office):
  - Section 9, Lighting, ASHRAE/IESNA Standard 90.1-1999/2001 [Attach backup\*]
  - Section 9, Lighting, ASHRAE/IESNA Standard 90.1-2004 [Attach backup\*]
- Chapter 7, NYS Energy Code allows whole building energy compliance to be demonstrated in accordance with the applicable provisions of ANSI/ASHRAE/IESNA/90.1. This project complies with the following version (verify with NYS Energy Office): [Attach backup\*].
  - Section 11, Energy Cost Budget Method, ANSI/ASHRAE/IESNA Standard 90.1-1999/2001
  - Section 11, Energy Cost Budget Method, ASHRAE/IESNA Standard 90.1-2004

If the performance path was used, whole building compliance verification and backup: (check below)

- was submitted to DDC on \_\_\_\_\_ date
- is attached
- will be submitted by \_\_\_\_\_ (consultant) on \_\_\_\_\_ (date)